

# CATALOGUE 2024



## SHOP FITTING

## DAMIX GROUP



- W1** SHOPPING TROLLEY
- W2** SPECIAL TROLLEYS, ACCESSORIES
- W3** TRANSPORT TROLLEYS
- S** CUSTOMER GUIDANCE SYSTEMS
- K** ROLLCONTAINERS
- E1** DISPLAY TABLE, WIRE BASKETS
- E2** PALLET CONTAINER, PALLET BOXES
- E3** SPECIAL RETAIL EQUIPMENT
- E4** EQUIPMENT FOR SHELVING, SHOP SHELVING
- P** PARKING

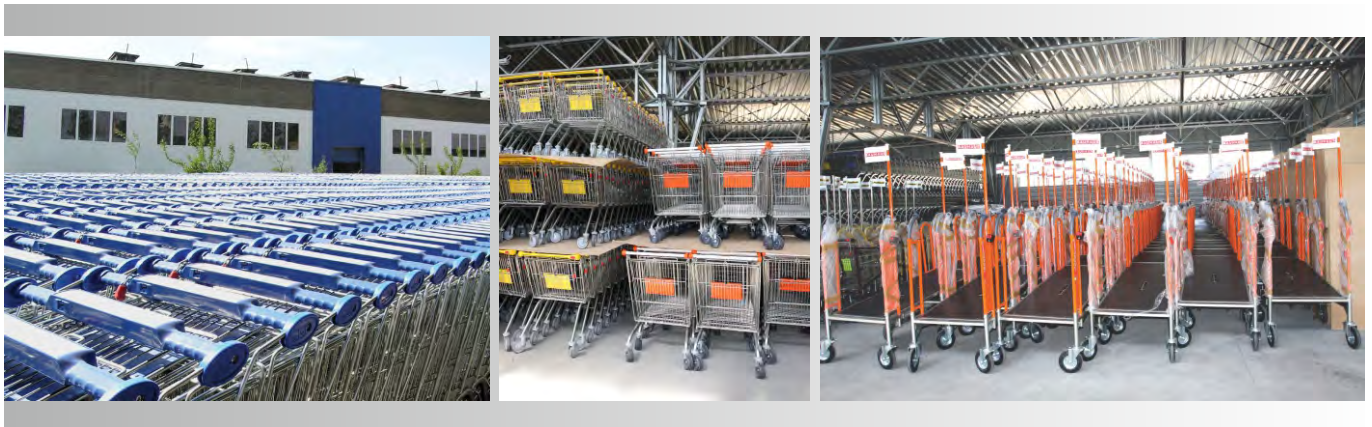

## ABOUT COMPANY



The company specializes in the production of equipment for shops, supermarkets, hypermarkets of each branch, warehouses and petrol stations. DAMIX recommends top-quality shopping trolleys - models Avant, Classic and transport trolleys - models Vario and Carry, as well as shelters for trolleys, a wide range of products for sale, presentation of products and for logistics. Electronic and mechanical gates produced by DAMIX, entrance and checkout, along with accessories allow you to create customer guidance systems. The fenders mounted to the ground and to the column are produced of stainless steel. The company also specializes in the production of advertising stands POS & POP.

Projects made of technological-construction team combined with years of experience and modern machinery made many reputable companies looking for and using good quality products from DAMIX's offer. The group of our customers includes renowned companies and chain of stores, a.o. in Poland, Austria, Belarus, Belgium, Denmark, Finland France, Germany, Holland, Lithuania, Norway, Russia, Sweden, Switzerland, Ukraine, UK, USA. Our partners are as well as customers from countries of southern Europe and Middle East.



### ISO 9001:2015

Our aim is to meet the needs of our customers better and better by providing high quality products. In the middle of 2004 we introduced a quality management system according to ISO 9001.

## DAMIX GROUP



## PRODUCTION BASE

The factory is located in Rypin on the area of over 50 000 m<sup>2</sup>. Factory objects have ca 25000 m<sup>2</sup> of floor space and are complementary equipped with many machines, devices and technological lines.

Laser for structurals

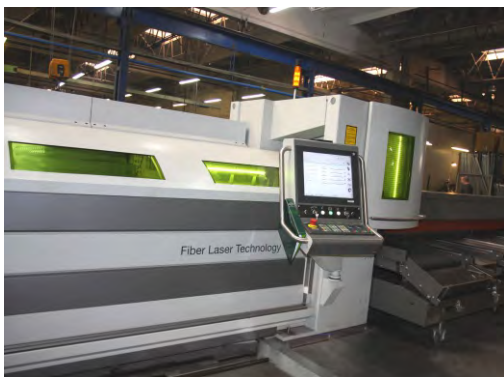

Laser for sheet metal



Presses and press brakes



Welding robots

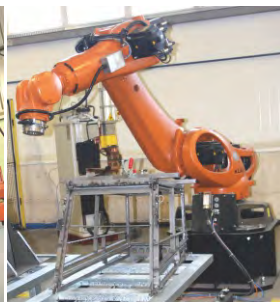

Bending machine for profiles



Robot for welding



Spot welders



Wire bending machines



Galvanic lines



Powder coating lines





## SHOPPING TROLLEYS

Shopping trolley is a concrete proposition for the shops and markets. It allows for comfortable and handy transportation of purchased goods. Good constructional solutions (pretty form of container, variety of the capacity, oval or round handles, oval plastic ends of the handles, wire valve with the plastic toddler seat, bottom stand made of oval profile, good quality wheels, optionally a bottom wire shelf in model CLASSIC) make us to be up with different expectations of our Customers. Connection of ergonomic construction with aesthetic form and manufacture make shopping with our trolleys feel like pleasure.

Handles used in our shopping trolleys are adapted inter alia to the locks for coins produced by company Systec POS-technology GmbH.



## **W1** SHOPPING TROLLEYS

- 1 Shopping trolley Andy H75
- 2 Shopping trolley Andy H90
- 3 Shopping trolley Andy H130
- 4 Shopping trolley Andy H160
- 5 Shopping trolley Andy H190
- 6 Shopping trolley Avant P75
- 7 Shopping trolley Avant P90
- 8 Shopping trolley Avant P140
- 9 Shopping trolley Avant 65
- 10 Shopping trolley Avant 75R
- 11 Shopping trolley Avant 80
- 12 Shopping trolley Avant 90
- 13 Shopping trolley Avant 90W
- 14 Shopping trolley Avant 100
- 15 Shopping trolley Avant 106
- 16 Shopping trolley Avant 130
- 17 Shopping trolley Avant 130P
- 18 Shopping trolley Avant 140
- 19 Shopping trolley Avant 150N
- 20 Shopping trolley Avant 185
- 21 Shopping trolley Avant 185P
- 22 Shopping trolley Avant 185N
- 23 Shopping trolley Avant 210AP
- 24 Shopping trolley Avant 212W
- 25 Shopping trolley Avant 215
- 26 Shopping trolley Avant 215AL
- 27 Shopping trolley Avant 240AS
- 28 Shopping trolley Classic 60
- 29 Shopping trolley Classic 70 SPECIAL
- 30 Shopping trolley Classic 90 Relaxt
- 31 Shopping trolley Classic 90
- 32 Shopping trolley Classic 90F
- 33 Shopping trolley Classic 110D
- 34 Shopping trolley Classic 100S
- 35 Shopping trolley Classic 125F
- 36 Shopping trolley Classic 140
- 37 Shopping trolley Classic 140M
- 38 Shopping trolley Classic 150F
- 39 Shopping trolley Classic 155
- 40 Shopping trolley Classic 155P
- 41 Shopping trolley Classic 180F
- 42 Shopping trolley Classic 180FP
- 43 Shopping trolley Classic 180K
- 44 Shopping trolley Classic 185
- 45 Shopping trolley Classic 185M
- 46 Shopping trolley Classic 185MP
- 47 Shopping trolley Classic 210A
- 48 Shopping trolley Classic 210F
- 49 Shopping trolley Classic 210CC
- 50 Shopping trolley Classic 212A

*The reproduce without prior permission is forbidden. In order to improve, the manufacturer reserves the right to implement modifications in its products. Recommendations for installation and use the products are provided for informational purposes only and does not imply any liability on the part of the manufacturer.*

## **W1** SHOPPING TROLLEYS

## SHOPPING TROLLEY ANDY H75



TYPE	Andy H75
BASKET CAPACITY	75 l
LOADING	75 kg
WHEEL DIAMETER	100 mm
FINISH	chassis: zinc plated + thermal setting lacquer
NESTING DISTANCE	110 mm

In the standard version shopping trolley has standard wheels. Optional accessories (inter alia wheels with brake, coin lock, the logo and other accessories) require separate arrangements.

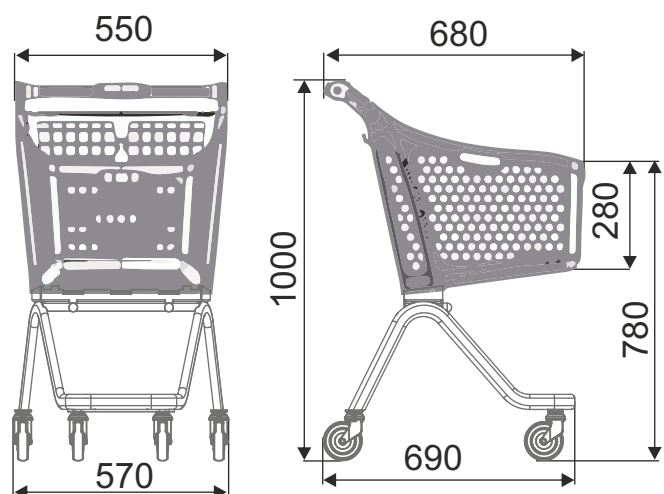

PRODUCT NAME	FINISH	INDEX
Shopping trolley Andy H75	basket - plastic, chassis - zinc plated + lacquer	-

### W1 SHOPPING TROLLEYS

## SHOPPING TROLLEY ANDY H90



TYPE	Andy H90
BASKET CAPACITY	100 l
LOADING	93 kg
WHEEL DIAMETER	125 mm
FINISH	chassis: zinc plated + thermal setting lacquer
NESTING DISTANCE	150 mm

In the standard version shopping trolley has standard wheels. Optional accessories (inter alia wheels for travelator or with brake, coin lock, the logo and other accessories) require separate arrangements.

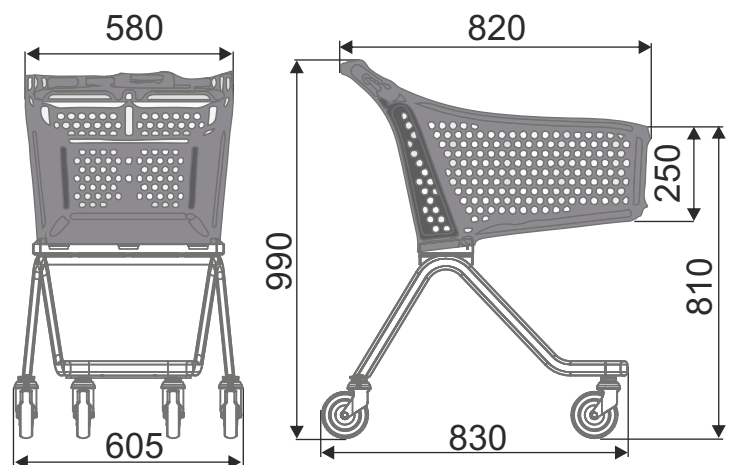

PRODUCT NAME	FINISH	INDEX
Shopping trolley Andy H90	basket - plastic, chassis - zinc plated + lacquer	-

### W1 SHOPPING TROLLEYS



## SHOPPING TROLLEY ANDY H130



TYPE	Andy H130
BASKET CAPACITY	130 l
LOADING	121 kg
WHEEL DIAMETER	125 mm
FINISH	chassis: zinc plated + thermal setting lacquer
NESTING DISTANCE	200 mm

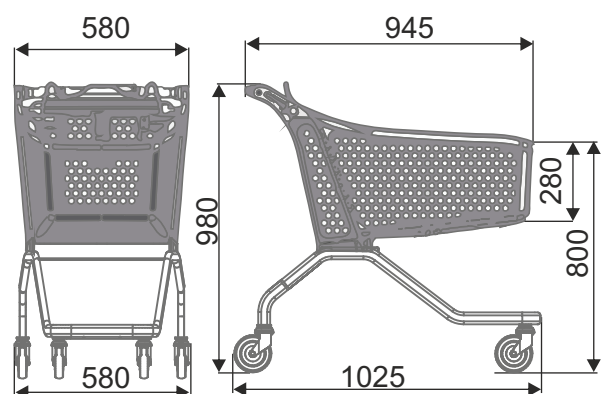

In the standard version shopping trolley has standard wheels. Optional accessories (inter alia wheels for travelator or with brake, coin lock, the logo and other accessories) require separate arrangements.

PRODUCT NAME	FINISH	INDEX
Shopping trolley Andy H130	plastic - basket, chassis - zinc plated + lacquer	-

### W1 SHOPPING TROLLEYS

## SHOPPING TROLLEY ANDY H160



TYPE	Andy H160
BASKET CAPACITY	160 l
LOADING	157 kg
WHEEL DIAMETER	125 mm
FINISH	chassis: zinc plated + thermal setting lacquer
NESTING DISTANCE	200 mm

In the standard version shopping trolley has standard wheels. Optional accessories (inter alia wheels for travelator or with brake, coin lock, the logo and other accessories) require separate arrangements. Note: If you use wheels for travelator, maximum loading of the trolley is 130 kg.

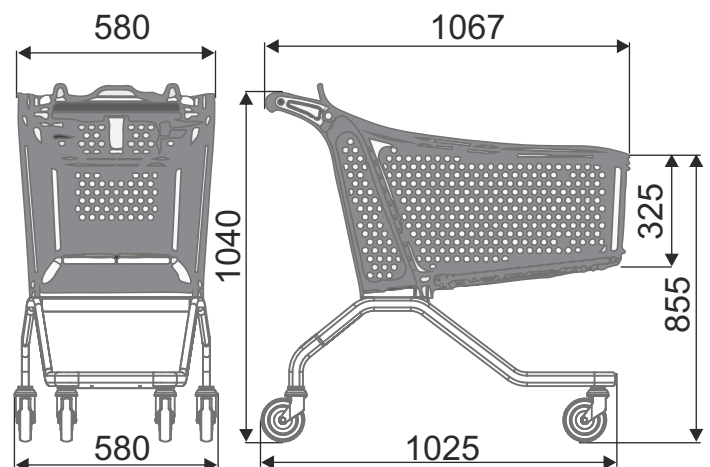

PRODUCT NAME	FINISH	INDEX
Shopping trolley Andy H160	plastic - basket, chassis - zinc plated + lacquer	-

### W1 SHOPPING TROLLEYS

## SHOPPING TROLLEY ANDY H190



TYPE	Andy H190
BASKET CAPACITY	184 l
LOADING	183 kg
WHEEL DIAMETER	125 mm
FINISH	chassis: zinc plated + thermal setting lacquer
NESTING DISTANCE	260 mm

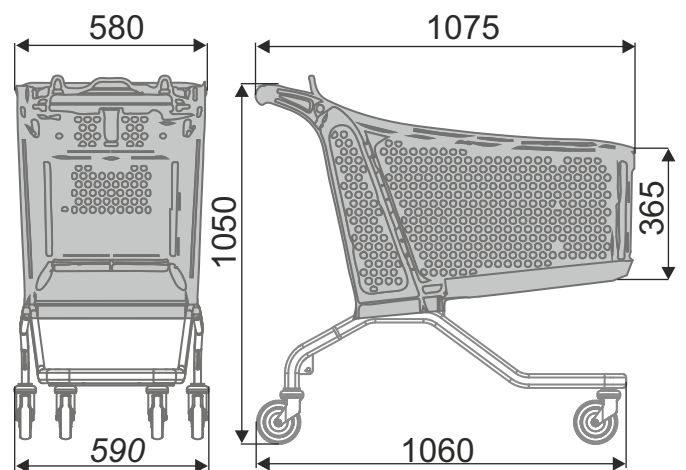

In the standard version shopping trolley has standard wheels. Optional accessories (inter alia wheels for travelator or with brake, coin lock, the logo and other accessories) require separate arrangements. Note: If you use wheels for travelator, maximum loading of the trolley is 130 kg.

PRODUCT NAME	FINISH	INDEX
Shopping trolley Andy H190	plastic - basket, chassis - zinc plated + lacquer	-

### W1 SHOPPING TROLLEYS

## SHOPPING TROLLEY AVANT P75



<b>TYPE</b>	Avant P75
<b>BASKET CAPACITY</b>	75 l
<b>LOADING</b>	75 kg
<b>WHEEL DIAMETER</b>	125 mm
<b>FINISH</b>	wire mesh: zinc plated + lacquer, frame: zinc plated + powder coating
<b>NESTING DISTANCE</b>	225 mm

In the standard version shopping trolley has standard wheels. Optional accessories (inter alia wheels for travelator or with brake, coin lock, the logo and other accessories) require separate arrangements.

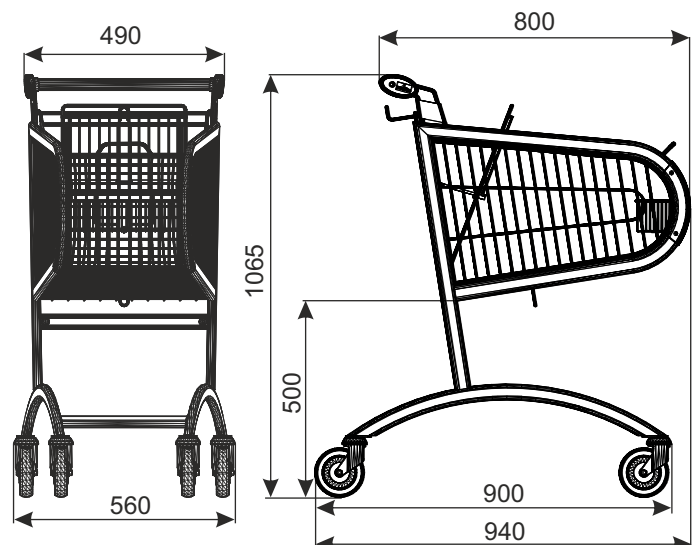

PRODUCT NAME	FINISH	INDEX
Shopping trolley Avant P75 with toddler seat	zinc plated + lacquer, zinc plated + powder coating	919-344-078

### W1 SHOPPING TROLLEYS

## SHOPPING TROLLEY AVANT P90



<b>TYPE</b>	Avant P90
<b>BASKET CAPACITY</b>	89 l
<b>LOADING</b>	89 kg
<b>WHEEL DIAMETER</b>	125 mm
<b>FINISH</b>	wire mesh: zinc plated + lacquer, frame: zinc plated + powder coating
<b>NESTING DISTANCE</b>	220 mm

In the standard version shopping trolley has standard wheels. Optional accessories (inter alia wheels for travelator or with brake, coin lock, the logo and other accessories) require separate arrangements.

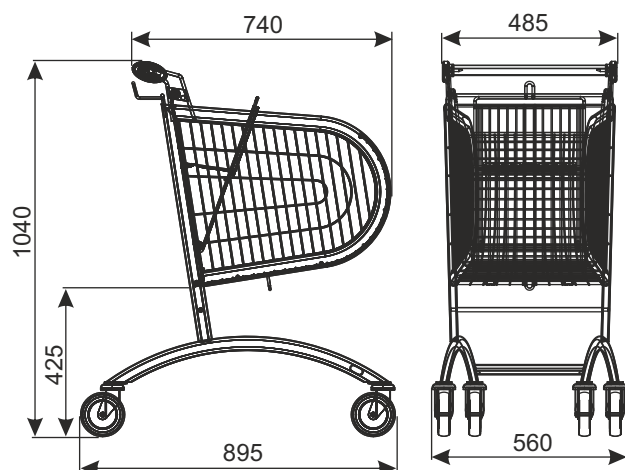

PRODUCT NAME	FINISH	INDEX
Shopping trolley Avant P90 with toddler seat	zinc plated + lacquer, zinc plated + powder coating	919-320-566

### **W1** SHOPPING TROLLEYS

## SHOPPING TROLLEY AVANT P140



<b>TYPE</b>	Avant P140
<b>BASKET CAPACITY</b>	134 l
<b>LOADING</b>	134 kg
<b>WHEEL DIAMETER</b>	125 mm
<b>FINISH</b>	wire mesh: zinc plated + lacquer, frame: zinc plated + powder coating
<b>NESTING DISTANCE</b>	220 mm

In the standard version shopping trolley has standard wheels. Optional accessories (inter alia wheels for travelator or with brake, coin lock, the logo and other accessories) require separate arrangements.

Note: If you use wheels for passenger conveyors, maximum loading of the trolley is 130 kg.

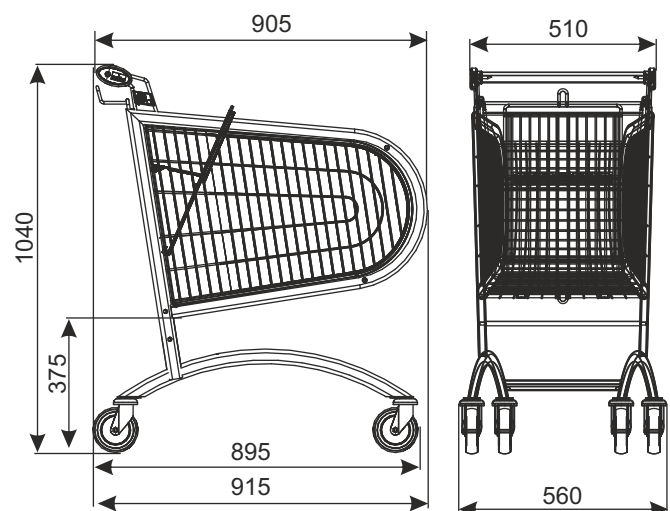

PRODUCT NAME	FINISH	INDEX
Shopping trolley Avant P140 with toddler seat	zinc plated + lacquer, zinc plated + powder coating	919-320-565

### W1 SHOPPING TROLLEYS

## SHOPPING TROLLEY AVANT 65

**NEW!**



<b>TYPE</b>	Avant 65
<b>BASKET CAPACITY</b>	65 l
<b>LOADING</b>	65 kg
<b>WHEEL DIAMETER</b>	125 mm
<b>FINISH</b>	zinc plated + thermal setting lacquer
<b>NESTING DISTANCE</b>	245 mm

In the standard version shopping trolley has standard wheels. Optional accessories (inter alia wheels for passenger conveyors or with brake, coin lock, the logo and other accessories) require separate arrangements.

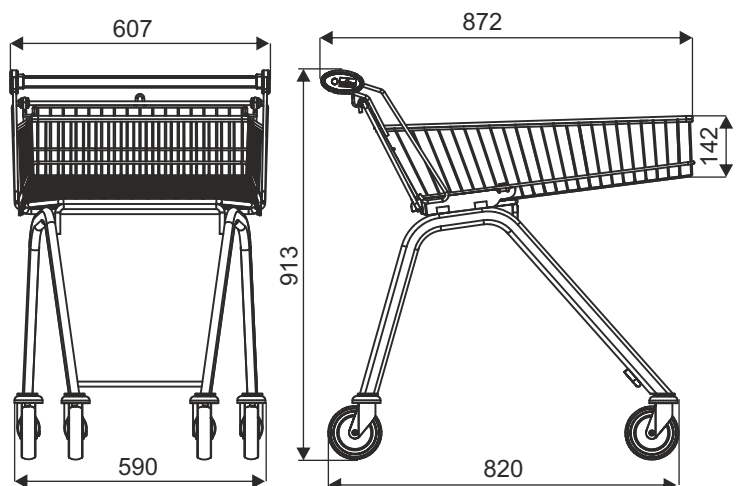

PRODUCT NAME	FINISH	INDEX
Shopping trolley Avant 65	zinc plated + lacquer	919-351-525

### **W1** SHOPPING TROLLEYS

## SHOPPING TROLLEY AVANT 75RS/ 75R



TYPE	Avant 75RS/ 75R
BASKET CAPACITY	75 l
LOADING	75 kg
WHEEL DIAMETER	100 mm
FINISH	zinc plated + thermal setting lacquer
NESTING DISTANCE	200 mm

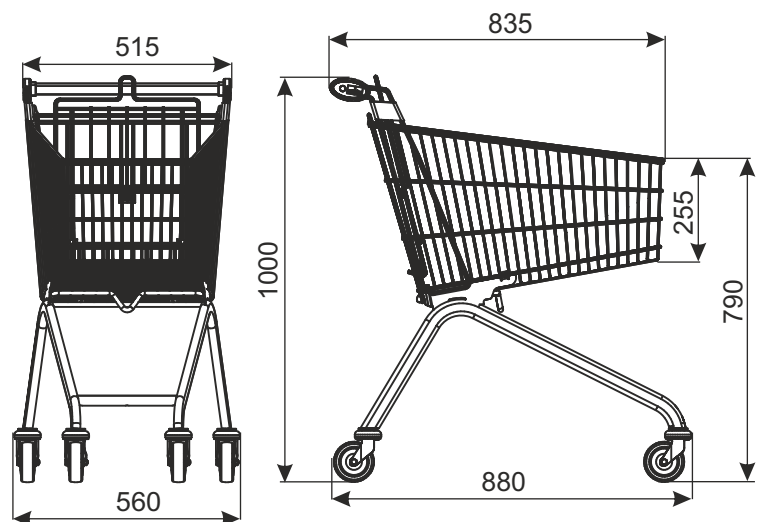

WIn the standard version shopping trolley has standard wheels. Optional accessories (inter alia wheels with brake, coin lock, the logo and other accessories) require separate arrangements.

PRODUCT NAME	FINISH	INDEX
Shopping trolley Avant 75R (WT-75RS) with toddler seat	zinc plated + lacquer	919-350-931

### W1 SHOPPING TROLLEYS



## SHOPPING TROLLEY AVANT 80



<b>TYPE</b>	Avant 80
<b>BASKET CAPACITY</b>	80 l
<b>LOADING</b>	80 kg
<b>WHEEL DIAMETER</b>	125 mm
<b>FINISH</b>	zinc plated + thermal setting lacquer/ optionally galvanic zinc + powder coating RAL 7016
<b>NESTING DISTANCE</b>	190 mm

In the standard version shopping trolley has standard wheels. Optional accessories (inter alia wheels for travelator or with brake, coin lock, the logo and other accessories) require separate arrangements.

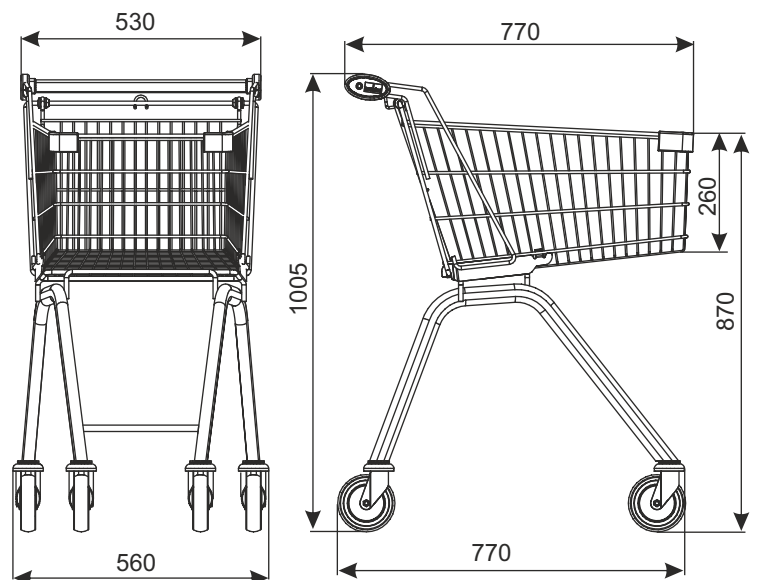

PRODUCT NAME	FINISH	INDEX
Shopping trolley Avant 80	zinc plated + lacquer	919-351-278
Shopping trolley Avant 80 powder coated RAL7016 (option)	zinc plated + powder coating	919-351-278

### W1 SHOPPING TROLLEYS

## SHOPPING TROLLEY AVANT 90



TYPE	Avant 90
BASKET CAPACITY	85 l
LOADING	85 kg
WHEEL DIAMETER	100 mm (optionally 125 mm)
FINISH	zinc plated + thermal setting lacquer
NESTING DISTANCE	180 mm

In the standard version shopping trolley has standard wheels. Optional accessories (inter alia wheels for passenger conveyors or with brake, coin lock, the logo and other accessories) require separate arrangements.

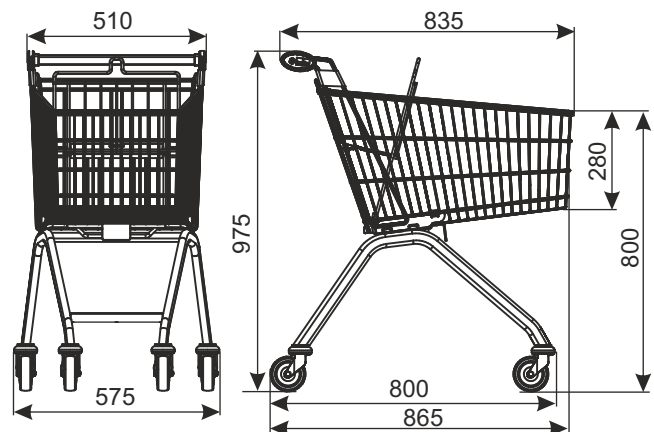

PRODUCT NAME	FINISH	INDEX
Shopping trolley Avant 90 with toddler seat	zinc plated + lacquer	919-350-702

### W1 SHOPPING TROLLEYS

## SHOPPING TROLLEY AVANT 90W



TYPE	Avant 90W
BASKET CAPACITY	85 l
LOADING	85 kg
WHEEL DIAMETER	125 mm
FINISH	zinc plated + thermal setting lacquer
NESTING DISTANCE	180 mm

In the standard version shopping trolley has standard wheels. Optional accessories (inter alia wheels for passenger conveyors or with brake, coin lock, the logo and other accessories) require separate arrangements.

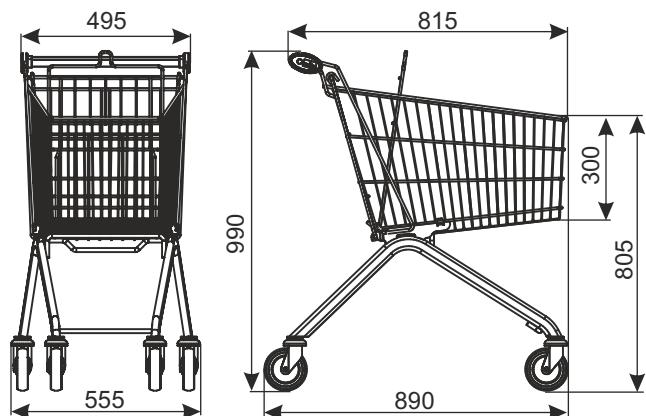

PRODUCT NAME	FINISH	INDEX
Shopping trolley Avant 90W with toddler seat	zinc plated + lacquer	919-351-420

### W1 SHOPPING TROLLEYS

## SHOPPING TROLLEY AVANT 100



<b>TYPE</b>	Avant 100
<b>BASKET CAPACITY</b>	99 l
<b>LOADING</b>	99 kg
<b>WHEEL DIAMETER</b>	100 mm
<b>FINISH</b>	zinc plated + thermal setting lacquer
<b>NESTING DISTANCE</b>	135 mm

In the standard version shopping trolley has standard wheels. Optional accessories (inter alia coin lock, the logo and other accessories) require separate arrangements.

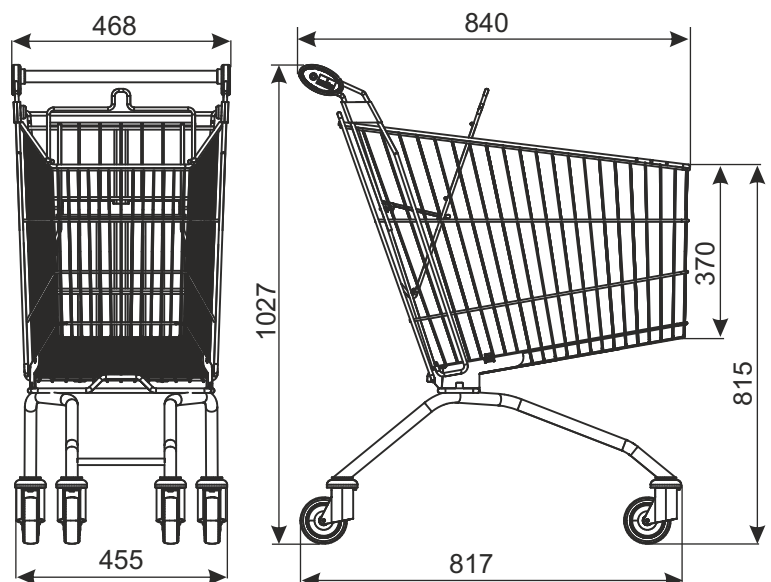

PRODUCT NAME	FINISH	INDEX
Shopping trolley Avant 100 with toddler seat	zinc plated + lacquer	919-351-021

### W1 SHOPPING TROLLEYS

## SHOPPING TROLLEY AVANT 106



<b>TYPE</b>	Avant 106
<b>BASKET CAPACITY</b>	101 l
<b>LOADING</b>	101 kg
<b>WHEEL DIAMETER</b>	125 mm
<b>FINISH</b>	zinc plated + thermal setting lacquer
<b>NESTING DISTANCE</b>	205 mm

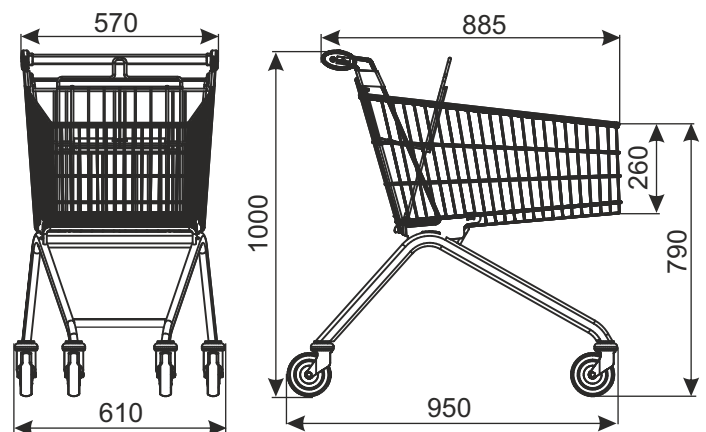

In the standard version shopping trolley has standard wheels. Optional accessories (inter alia wheels for travelator or with brake, coin lock, the logo and other accessories) require separate arrangements.

PRODUCT NAME	FINISH	INDEX
Shopping trolley Avant 106 with toddler seat	zinc plated + lacquer	919-350-814

### W1 SHOPPING TROLLEYS

## SHOPPING TROLLEY AVANT 130



TYPE	Avant 130
BASKET CAPACITY	130 l
LOADING	130 kg
WHEEL DIAMETER	125 mm
FINISH	zinc plated + thermal setting lacquer
NESTING DISTANCE	210 mm

In the standard version shopping trolley has standard wheels. Optional accessories (inter alia wheels for travelator or with brake, coin lock, the logo and other accessories) require separate arrangements.

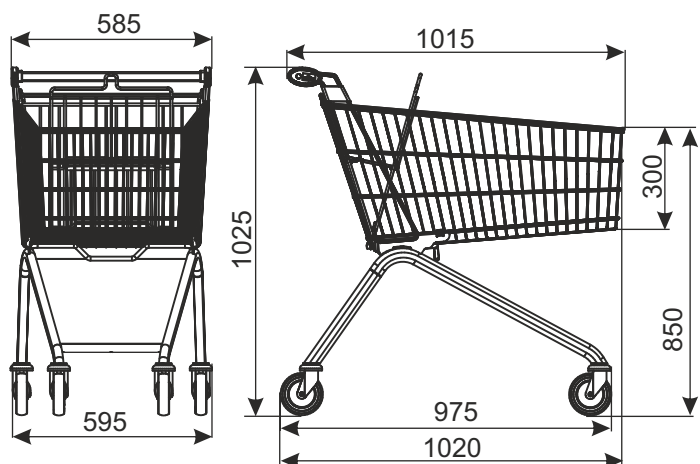

PRODUCT NAME	FINISH	INDEX
Shopping trolley Avant 130 with toddler seat	zinc plated + lacquer	919-351-293

### W1 SHOPPING TROLLEYS

## SHOPPING TROLLEY AVANT 130P



TYPE	Avant 130P
BASKET CAPACITY	130 l
LOADING OF THE SHELF FOR MULTI-PACK	30 kg
LOADING	160 kg
WHEEL DIAMETER	125 mm
FINISH	zinc plated + thermal setting lacquer
NESTING DISTANCE	210 mm

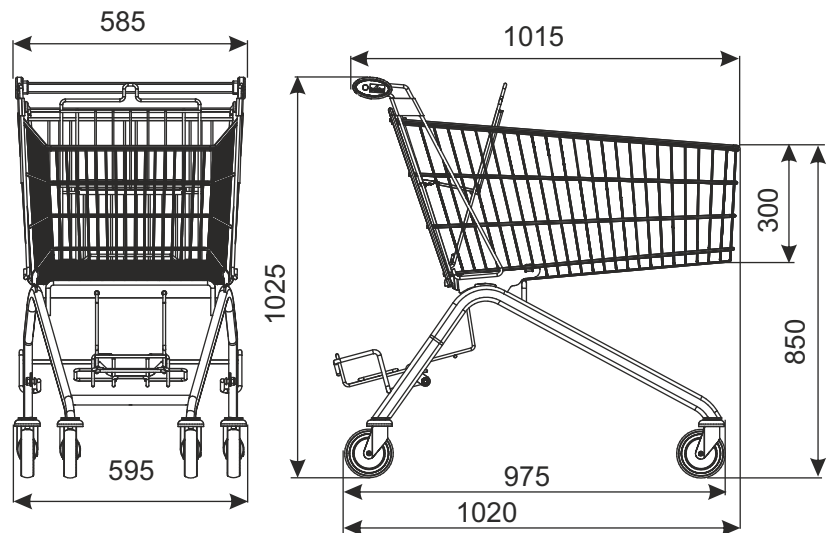

In the standard version shopping trolley has standard wheels. Optional accessories (inter alia wheels for travelator or with brake, coin lock, the logo and other accessories) require separate arrangements.  
Note: If you use wheels for travelator, maximum loading of the trolley is 130 kg.

PRODUCT NAME	FINISH	INDEX
Shopping trolley Avant 130P with toddler seat	zinc plated + lacquer	_____

### W1 SHOPPING TROLLEYS

## SHOPPING TROLLEY AVANT 140



TYPE	Avant 140
BASKET CAPACITY	136 l
LOADING	136 kg
WHEEL DIAMETER	125 mm
FINISH	zinc plated + thermal setting lacquer
NESTING DISTANCE	220 mm

In the standard version shopping trolley has standard wheels. Optional accessories (inter alia wheels for travelator or with brake, coin lock, the logo and other accessories) require separate arrangements. Note: If you use wheels for travelator, maximum loading of the trolley is 130 kg.

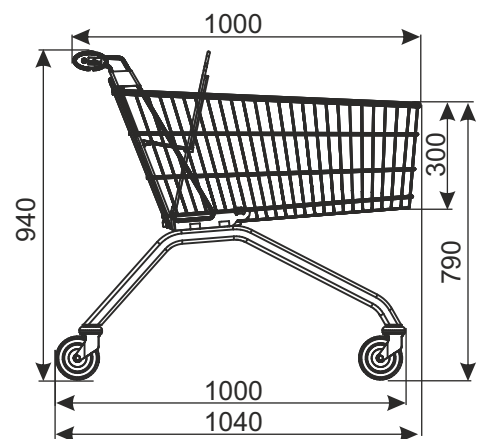

PRODUCT NAME	FINISH	INDEX
Shopping trolley Avant 140 with toddler seat	zinc plated + lacquer	919-350-700

### W1 SHOPPING TROLLEYS



## SHOPPING TROLLEY AVANT 150N



TYPE	Avant 150N
BASKET CAPACITY	151 l
LOADING	151 kg
WHEEL DIAMETER	125 mm
FINISH	zinc plated + thermal setting lacquer
NESTING DISTANCE	220 mm

In the standard version shopping trolley has standard wheels. Optional accessories (inter alia wheels for travelator or with brake, coin lock, the logo and other accessories) require separate arrangements. Note: If you use wheels for travelator, maximum loading of the trolley is 130 kg.

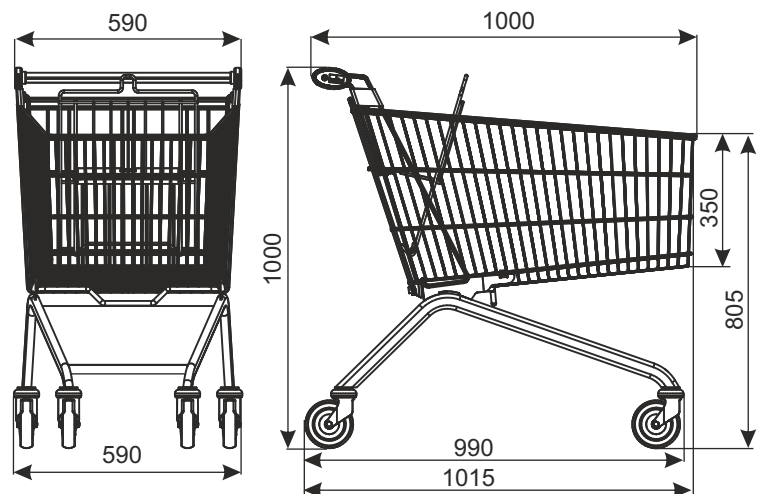

PRODUCT NAME	FINISH	INDEX
Shopping trolley Avant 150N with toddler seat	zinc plated + lacquer	919-351-075

### W1 SHOPPING TROLLEYS

## SHOPPING TROLLEY AVANT 185



TYPE	Avant 185
BASKET CAPACITY	178 l
LOADING	178 kg
WHEEL DIAMETER	125 mm
FINISH	zinc plated + thermal setting lacquer
NESTING DISTANCE	210 mm

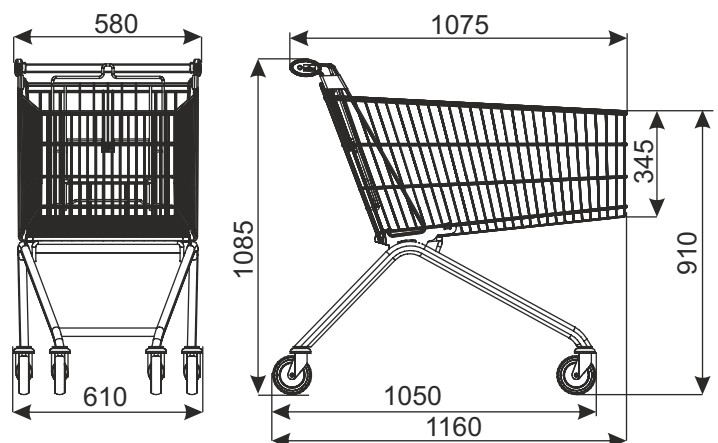

In the standard version shopping trolley has standard wheels. Optional accessories (inter alia wheels for travelator or with brake, coin lock, the logo and other accessories) require separate arrangements.  
Note: If you use wheels for travelator, maximum loading of the trolley is 130 kg.

PRODUCT NAME	FINISH	INDEX
Shopping trolley Avant 185 with toddler seat	zinc plated + lacquer	919-351-095

### W1 SHOPPING TROLLEYS

## SHOPPING TROLLEY AVANT 185P



TYPE	Avant 185P
BASKET CAPACITY	178 l
LOADING OF THE SHELF FOR MULTI-PACK	20 kg
LOADING	198 kg
WHEEL DIAMETER	125 mm
FINISH	zinc plated + thermal setting lacquer
NESTING DISTANCE	210 mm

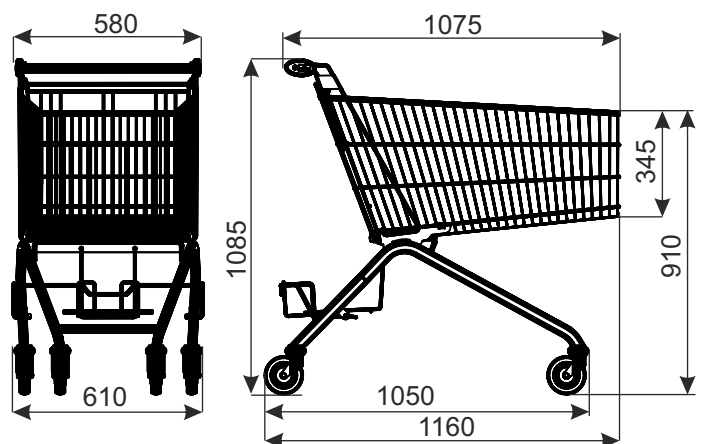

In the standard version shopping trolley has standard wheels. Optional accessories (inter alia wheels for travelator or with brake, coin lock, the logo and other accessories) require separate arrangements.

Note: If you use wheels for travelator, maximum loading of the trolley is 130 kg.

PRODUCT NAME	FINISH	INDEX
Shopping trolley Avant 185P with toddler seat	zinc plated + lacquer	—

### W1 SHOPPING TROLLEYS

## SHOPPING TROLLEY AVANT 185N



<b>TYPE</b>	Avant 185N
<b>BASKET CAPACITY</b>	178 l
<b>LOADING</b>	178 kg
<b>WHEEL DIAMETER</b>	125 mm
<b>FINISH</b>	zinc plated + thermal setting lacquer
<b>NESTING DISTANCE</b>	245 mm

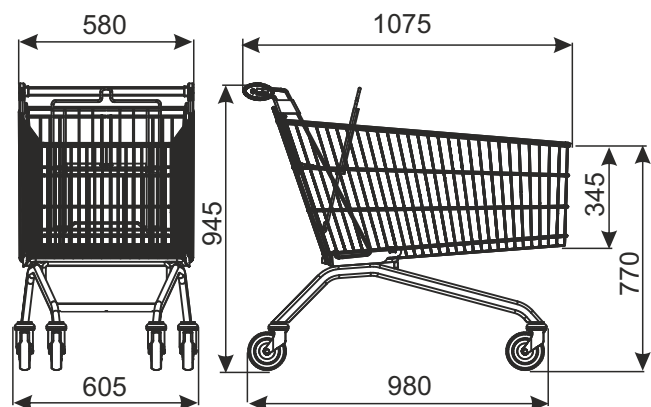

In the standard version shopping trolley has standard wheels. Optional accessories (inter alia wheels for travelator or with brake, coin lock, the logo and other accessories) require separate arrangements.  
Note: If you use wheels for travelator, maximum loading of the trolley is 130 kg.

PRODUCT NAME	FINISH	INDEX
Shopping trolley Avant 185N with toddler seat	zinc plated + lacquer	919-351-088

### **W1** SHOPPING TROLLEYS

## SHOPPING TROLLEY AVANT 210 AP



<b>TYPE</b>	Avant 210 AP
<b>BASKET CAPACITY</b>	203 l
<b>LOADING</b>	203 kg
<b>WHEEL DIAMETER</b>	125 mm
<b>FINISH</b>	zinc plated + thermal setting lacquer
<b>NESTING DISTANCE</b>	235 mm

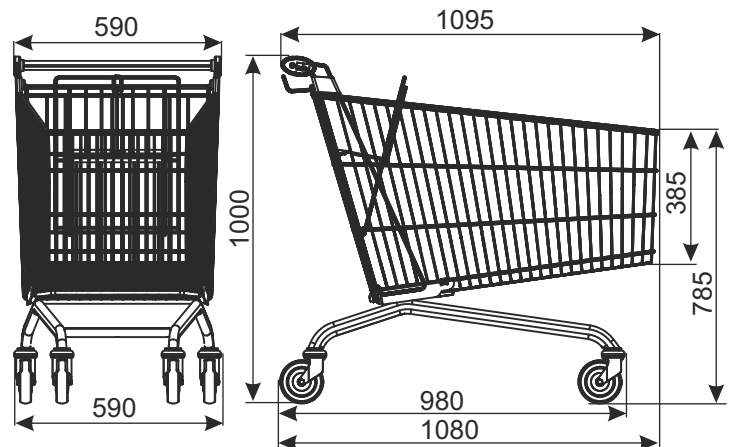

In the standard version shopping trolley has standard wheels. Optional accessories (inter alia wheels for travelator or with brake, coin lock, the logo and other accessories) require separate arrangements.  
Note: If you use wheels for travelator, maximum loading of the trolley is 130 kg.

PRODUCT NAME	FINISH	INDEX
Shopping trolley Avant 210 AP with toddler seat	zinc plated + lacquer	919-350-888

### **W1** SHOPPING TROLLEYS

## SHOPPING TROLLEY AVANT 212W



TYPE	Avant 212W
BASKET CAPACITY	206 l
LOADING	206 kg
WHEEL DIAMETER	125 mm
FINISH	zinc plated + thermal setting lacquer
NESTING DISTANCE	240 mm

In the standard version shopping trolley has standard wheels. Optional accessories (inter alia wheels for travelator or with brake, coin lock, the logo and other accessories) require separate arrangements. Note: If you use wheels for travelator, maximum loading of the trolley is 130 kg.

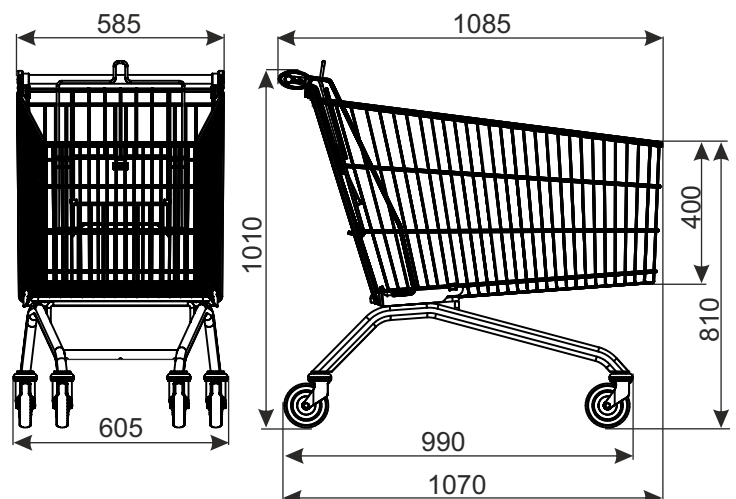

PRODUCT NAME	FINISH	INDEX
Shopping trolley Avant 212W with toddler seat	zinc plated + lacquer	919-351-408

### W1 SHOPPING TROLLEYS

## SHOPPING TROLLEY AVANT 215



TYPE	Avant 215
BASKET CAPACITY	215 l
LOADING	215 kg
WHEEL DIAMETER	125 mm
FINISH	zinc plated + thermal setting lacquer
NESTING DISTANCE	220 mm

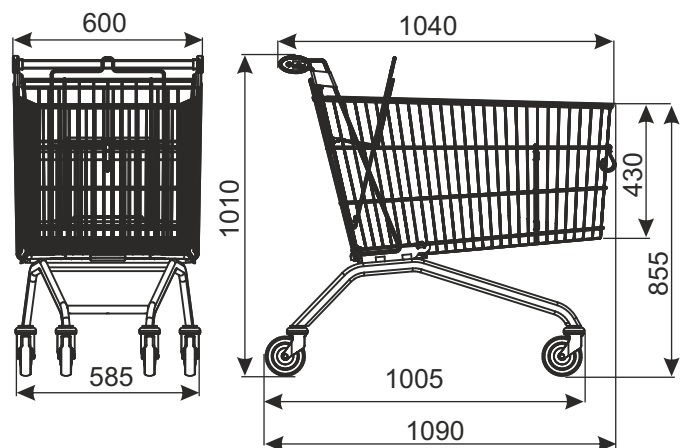

In the standard version shopping trolley has standard wheels. Optional accessories (inter alia wheels for travelator or with brake, coin lock, the logo and other accessories) require separate arrangements. Note: If you use wheels for travelator, maximum loading of the trolley is 130 kg.

PRODUCT NAME	FINISH	INDEX
Shopping trolley Avant 215 with toddler seat	zinc plated + lacquer	919-350-716

### W1 SHOPPING TROLLEYS

## SHOPPING TROLLEY AVANT 215 AL



TYPE	Avant 215 AL
BASKET CAPACITY	206 l
LOADING	206 kg
WHEEL DIAMETER	125 mm
FINISH	zinc plated + thermal setting lacquer
NESTING DISTANCE	240 mm

In the standard version shopping trolley has standard wheels. Optional accessories (inter alia wheels for travelator or with brake, coin lock, the logo and other accessories) require separate arrangements.  
Note: If you use wheels for travelator, maximum loading of the trolley is 130 kg.

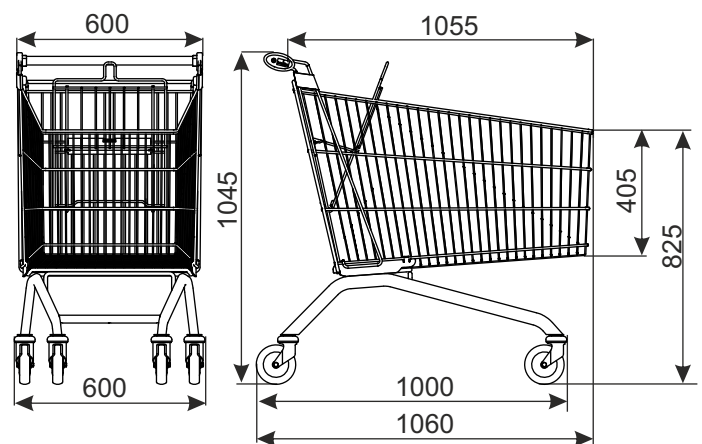

PRODUCT NAME	FINISH	INDEX
Shopping trolley Avant 215 AL with toddler seat	zinc plated + lacquer	919-350-902

### W1 SHOPPING TROLLEYS



## SHOPPING TROLLEY AVANT 240AS



TYPE	Avant 240AS
BASKET CAPACITY	240 l
LOADING	240 kg
WHEEL DIAMETER	125 mm
FINISH	zinc plated + thermal setting lacquer
NESTING DISTANCE	245 mm

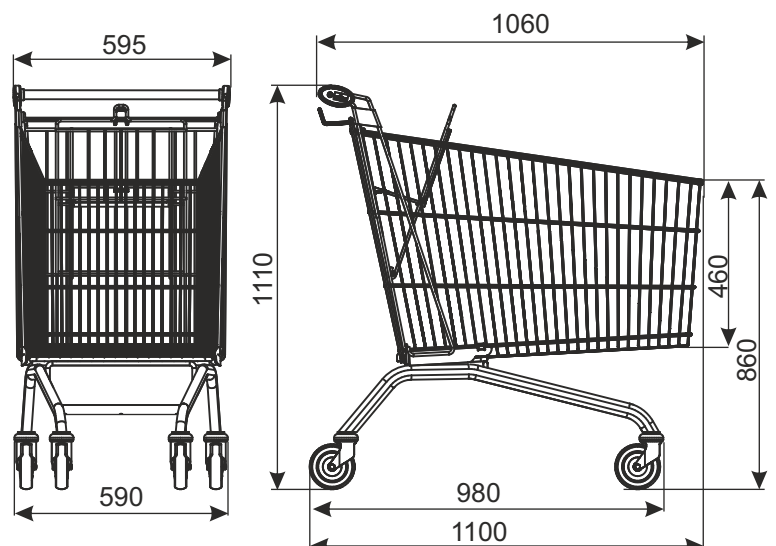

In the standard version shopping trolley has standard wheels. Optional accessories (inter alia wheels for travelator or with brake, coin lock, the logo and other accessories) require separate arrangements. Note: If you use wheels for travelator, maximum loading of the trolley is 130 kg.

PRODUCT NAME	FINISH	INDEX
Shopping trolley Avant 240 AS with toddler seat	zinc plated + lacquer	919-351-049

### W1 SHOPPING TROLLEYS

## SHOPPING TROLLEY CLASSIC 60



<b>TYPE</b>	Classic 60
<b>BASKET CAPACITY</b>	60 l
<b>LOADING OF BASKET</b>	60 kg
<b>TOTAL LOADING</b>	85 kg
<b>WHEEL DIAMETER</b>	125 mm
<b>FINISH</b>	zinc plated + thermal setting lacquer/ optionally galvanic zinc + powder coating RAL 7016
<b>NESTING DISTANCE</b>	180 mm

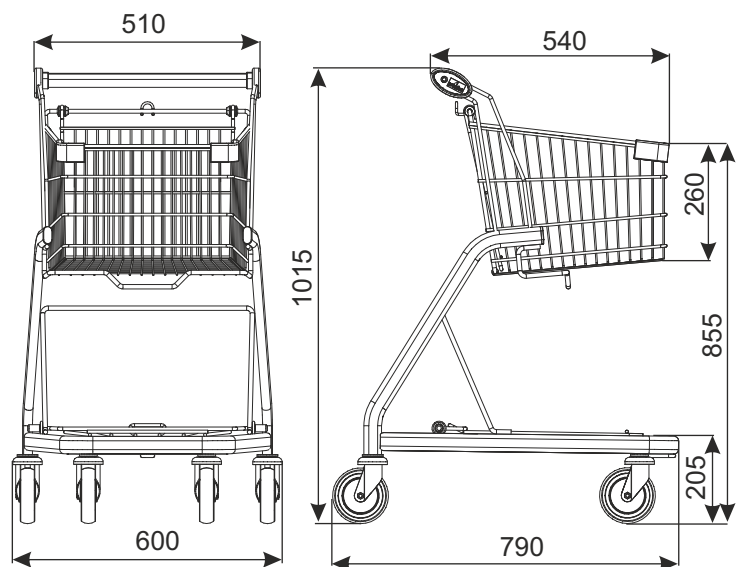

In the standard version shopping trolley has standard wheels. Optional accessories (inter alia wheels for travelator or with brake, coin lock, the logo and other accessories) require separate arrangements.

PRODUCT NAME	FINISH	INDEX
Shopping trolley Classic 60	zinc plated + lacquer	—
Shopping trolley Classic 60 powder coated RAL7016 (option)	zinc plated + powder coating	919-351-279

### W1 SHOPPING TROLLEYS

## SHOPPING TROLLEY CLASSIC 70 SPECIAL (WT-70RPS)



TYPE	Classic 70 SPECIAL
BASKET CAPACITY	70 l
LOADING OF BASKET	70 kg
TOTAL LOADING	110 kg
WHEEL DIAMETER	125 mm
NESTING DISTANCE	230 mm

In the standard version shopping trolley has standard wheels and is without the logo and coin lock. Optional accessories (inter alia wheels for travelator or with brake, locks and other accessories) require separate arrangements.

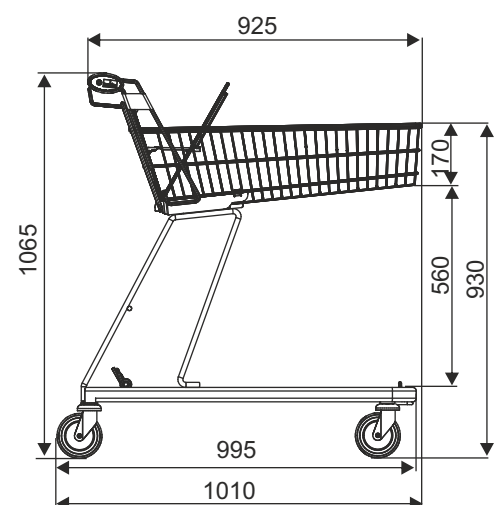
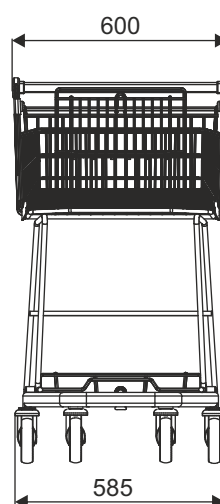

PRODUCT NAME	FINISH	INDEX
Shopping trolley Classic 70 SPECIAL (WT-70RPS) with toddler seat	zinc plated + lacquer	919-351-202

### W1 SHOPPING TROLLEYS

## SHOPPING TROLLEY CLASSIC 90 RELAXT



The trolley is equipped with an original, modern handle with a built-in coin lock, anti-static protection and a place for an advertising. The construction of the handle ensures easy maneuvering of the loaded trolley.



TYPE	Classic 90 Relaxt
BASKET CAPACITY	85 l
LOADING OF BASKET	85 kg
TOTAL LOADING	125 kg
WHEEL DIAMETER	125 mm
FINISH	zinc plated + thermal setting lacquer
NESTING DISTANCE	180 mm

In the standard version shopping trolley has standard wheels. Optional accessories (inter alia wheels for travelator or with brake, coin lock, the logo and other accessories) require separate arrangements.

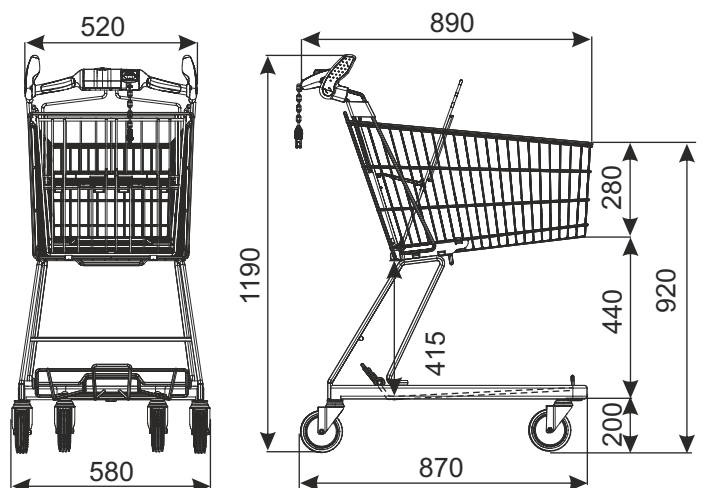

PRODUCT NAME	FINISH	INDEX
Shopping trolley Classic 90 Relaxt with toddler seat	zinc plated + lacquer	_____

### W1 SHOPPING TROLLEYS

## SHOPPING TROLLEY CLASSIC 90



<b>TYPE</b>	Classic 90
<b>BASKET CAPACITY</b>	85 l
<b>LOADING OF BASKET</b>	85 kg
<b>TOTAL LOADING</b>	125 kg
<b>WHEEL DIAMETER</b>	100 mm (optionally 125 mm)
<b>FINISH</b>	zinc plated + thermal setting lacquer
<b>NESTING DISTANCE</b>	180 mm

In the standard version shopping trolley has standard wheels. Optional accessories (inter alia wheels for travelator or with brake, coin lock, the logo and other accessories) require separate arrangements.

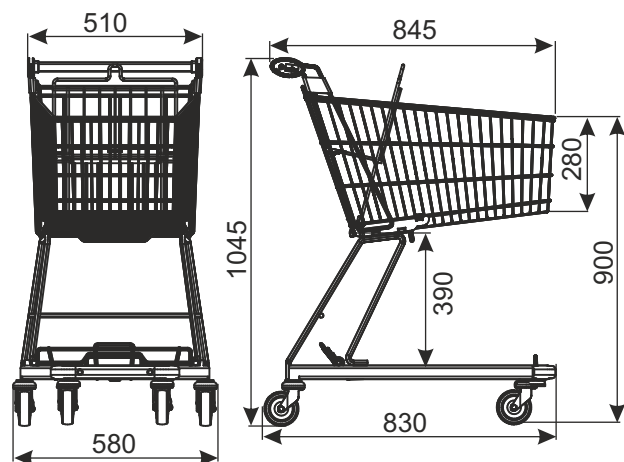

PRODUCT NAME	FINISH	INDEX
Shopping trolley Classic 90 with toddler seat	zinc plated + lacquer	919-350-718

### W1 SHOPPING TROLLEYS

## SHOPPING TROLLEY CLASSIC 90F



<b>TYPE</b>	Classic 90F
<b>BASKET CAPACITY</b>	95 l
<b>LOADING</b>	95 kg
<b>WHEEL DIAMETER</b>	100 mm
<b>FINISH</b>	zinc plated + thermal setting lacquer
<b>NESTING DISTANCE</b>	190 mm

In the standard version shopping trolley has standard wheels. Optional accessories (inter alia coin lock, the logo and other accessories) require separate arrangements.

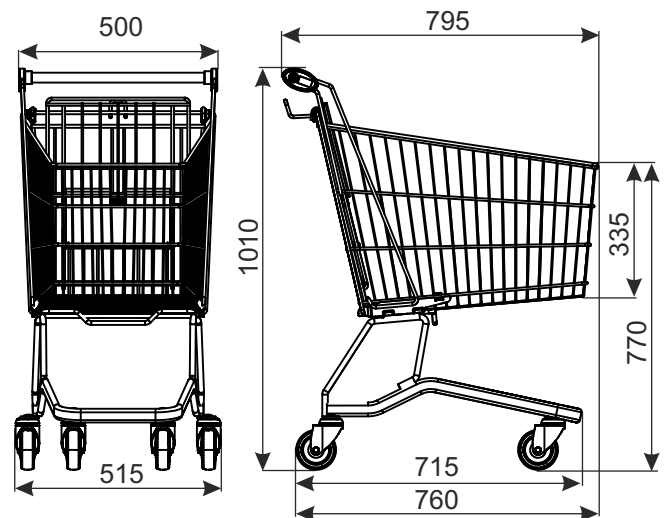

PRODUCT NAME	FINISH	INDEX
Shopping trolley Classic 90F with toddler seat	zinc plated + lacquer	919-351-336

### W1 SHOPPING TROLLEYS

## SHOPPING TROLLEY CLASSIC 110D

**NEW!**



<b>TYPE</b>	Classic 110D
<b>BASKET CAPACITY</b>	110 l
<b>LOADING OF BASKET</b>	110 kg
<b>TOTAL LOADING</b>	140 kg
<b>WHEEL DIAMETER</b>	100 mm
<b>FINISH</b>	zinc plated + thermal setting lacquer
<b>NESTING DISTANCE</b>	165 mm

In the standard version shopping trolley has standard wheels. Optional accessories (inter alia coin lock, the logo and other accessories) require separate arrangements.

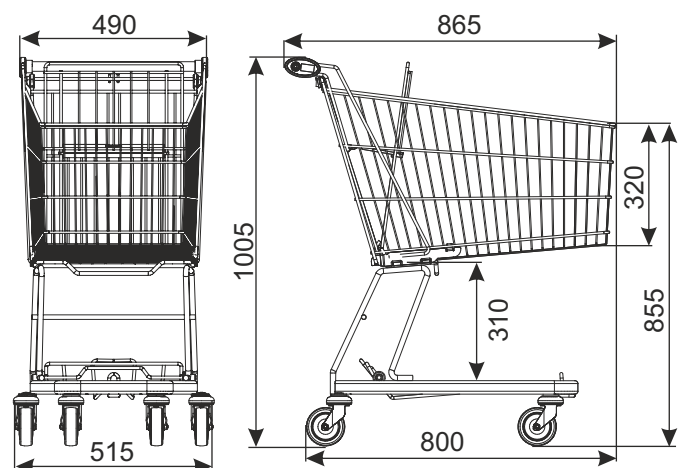

PRODUCT NAME	FINISH	INDEX
Shopping trolley Classic 110D with toddler seat	zinc plated + lacquer	919-351-604

### **W1** SHOPPING TROLLEYS

## SHOPPING TROLLEY CLASSIC 100S



TYPE	Classic 100S
BASKET CAPACITY	100 l
LOADING OF BASKET	100 kg
TOTAL LOADING	130 kg
WHEEL DIAMETER	125 mm
FINISH	zinc plated + thermal setting lacquer
NESTING DISTANCE	220 mm

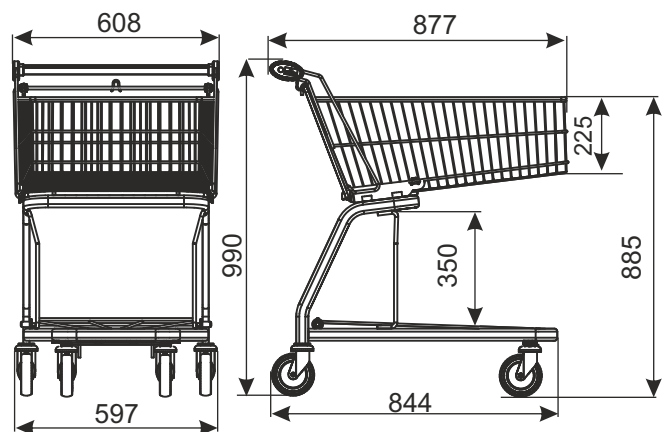

In the standard version shopping trolley has standard wheels. Optional accessories (inter alia coin lock, the logo and other accessories) require separate arrangements.

PRODUCT NAME	FINISH	INDEX
Shopping trolley Classic 100S	zinc plated + lacquer	919-351-529

### W1 SHOPPING TROLLEYS



## SHOPPING TROLLEY CLASSIC 125F



<b>TYPE</b>	Classic 125F
<b>BASKET CAPACITY</b>	125 l
<b>LOADING</b>	125 kg
<b>WHEEL DIAMETER</b>	125 mm
<b>FINISH</b>	zinc plated + thermal setting lacquer
<b>NESTING DISTANCE</b>	220 mm

In the standard version shopping trolley has standard wheels. Optional accessories (inter alia wheels for travelator or with brake, coin lock, the logo and other accessories) require separate arrangements.

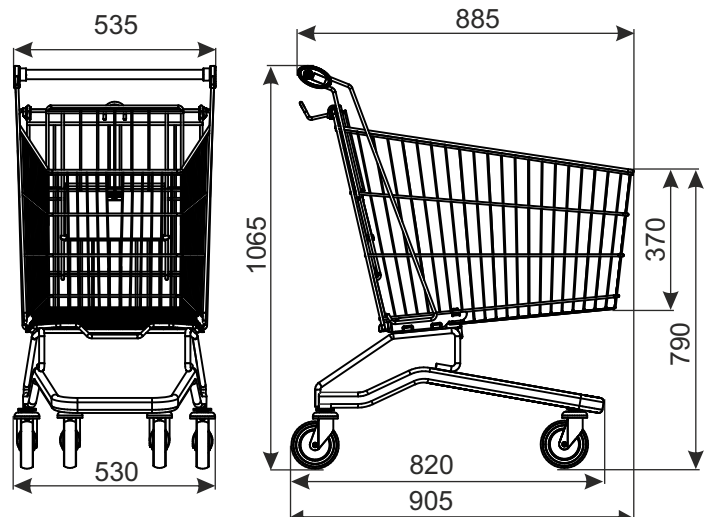

PRODUCT NAME	FINISH	INDEX
Shopping trolley Classic 125F with toddler seat	zinc plated + lacquer	919-351-337

### W1 SHOPPING TROLLEYS

## SHOPPING TROLLEY CLASSIC 140



TYPE	Classic 140
BASKET CAPACITY	136 l
LOADING OF BASKET	136 kg
TOTAL LOADING	186 kg
WHEEL DIAMETER	125 mm
FINISH	zinc plated + thermal setting lacquer
NESTING DISTANCE	220 mm

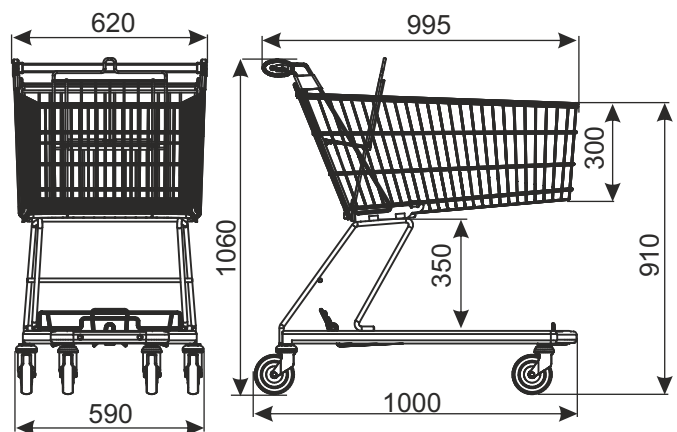

In the standard version shopping trolley has standard wheels. Optional accessories (inter alia wheels for travelator or with brake, coin lock, the logo and other accessories) require separate arrangements.  
Note: If you use wheels for travelator, maximum loading of the trolley is 130 kg.

PRODUCT NAME	FINISH	INDEX
Shopping trolley Classic 140 with toddler seat	zinc plated + lacquer	919-350-720

### W1 SHOPPING TROLLEYS

## SHOPPING TROLLEY CLASSIC 140M



<b>TYPE</b>	Classic 140M
<b>BASKET CAPACITY</b>	140 l
<b>LOADING OF BASKET</b>	140 kg
<b>TOTAL LOADING</b>	190 kg
<b>WHEEL DIAMETER</b>	125 mm
<b>FINISH</b>	zinc plated + thermal setting lacquer
<b>NESTING DISTANCE</b>	265 mm

In the standard version shopping trolley has standard wheels. Optional accessories (inter alia wheels for travelator or with brake, coin lock, the logo and other accessories) require separate arrangements. Textiles holder is optional equipment.  
Note: If you use wheels for travelator, maximum loading of the trolley is 130 kg.

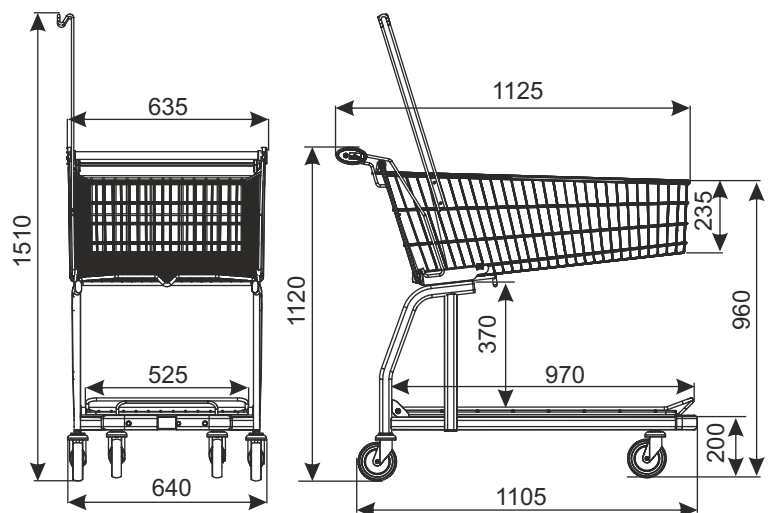

PRODUCT NAME	FINISH	INDEX
Shopping trolley Classic 140M	zinc plated + lacquer	919-351-176
Shopping trolley Classic 140M with toddler seat	zinc plated + lacquer	919-351-176 v2
Textiles holder for shopping trolley 140M (optional)	zinc plated + lacquer	919-351-172

### W1 SHOPPING TROLLEYS

## SHOPPING TROLLEY CLASSIC 150F



<b>TYPE</b>	Classic 150F
<b>BASKET CAPACITY</b>	156 l
<b>LOADING</b>	156 kg
<b>WHEEL DIAMETER</b>	125 mm
<b>FINISH</b>	zinc plated + thermal setting lacquer
<b>NESTING DISTANCE</b>	225 mm

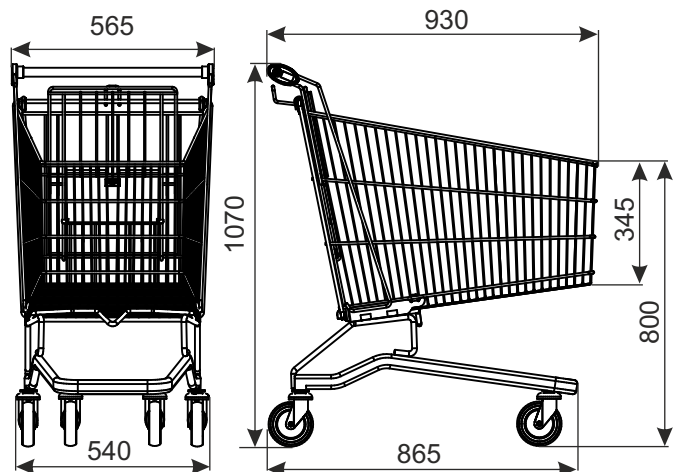

In the standard version shopping trolley has standard wheels. Optional accessories (inter alia wheels for travelator or with brake, coin lock, the logo and other accessories) require separate arrangements.  
Note: If you use wheels for travelator, maximum loading of the trolley is 130 kg.

PRODUCT NAME	FINISH	INDEX
Shopping trolley Classic 150F with toddler seat	zinc plated + lacquer	919-351-338

### W1 SHOPPING TROLLEYS

## SHOPPING TROLLEY CLASSIC 155



TYPE	Classic 155
BASKET CAPACITY	143 l
LOADING OF BASKET	143 kg
TOTAL LOADING	190 kg
WHEEL DIAMETER	125 mm
FINISH	zinc plated + thermal setting lacquer
NESTING DISTANCE	245 mm

In the standard version shopping trolley has standard wheels. Optional accessories (inter alia wheels for travelator or with brake, coin lock, the logo and other accessories) require separate arrangements. Note: If you use wheels for travelator, maximum loading of the trolley is 130 kg.

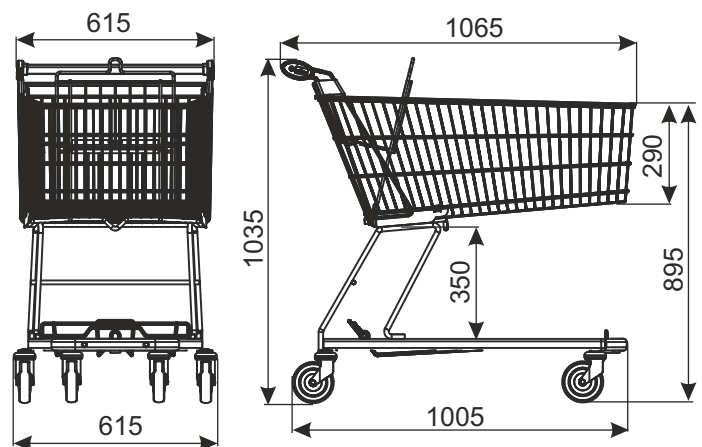

PRODUCT NAME	FINISH	INDEX
Shopping trolley Classic 155 with toddler seat	zinc plated + lacquer	919-350-807

### W1 SHOPPING TROLLEYS

## SHOPPING TROLLEY CLASSIC 155P (with the shelf for multi-pack)



TYPE	Classic 155P
BASKET CAPACITY	143 l
LOADING OF BASKET	143 kg
LOADING OF THE SHELF FOR MULTI-PACK	30 kg
TOTAL LOADING	210 kg
WHEEL DIAMETER	125 mm
FINISH	zinc plated + thermal setting lacquer
NESTING DISTANCE	245 mm

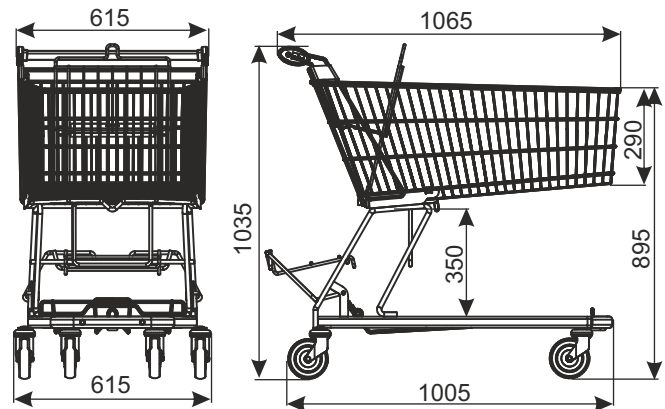

In the standard version shopping trolley has standard wheels. Optional accessories (inter alia wheels for travelator or with brake, coin lock, the logo and other accessories) require separate arrangements.  
Note: If you use wheels for travelator, maximum loading of the trolley is 130 kg.

PRODUCT NAME	FINISH	INDEX
Shopping trolley Classic 155P with toddler seat	zinc plated + lacquer	919-350-807

### W1 SHOPPING TROLLEYS

## SHOPPING TROLLEY CLASSIC 180F



TYPE	Classic 180F
BASKET CAPACITY	177 l
LOADING	177 kg
WHEEL DIAMETER	125 mm
FINISH	zinc plated + thermal setting lacquer
NESTING DISTANCE	205 mm

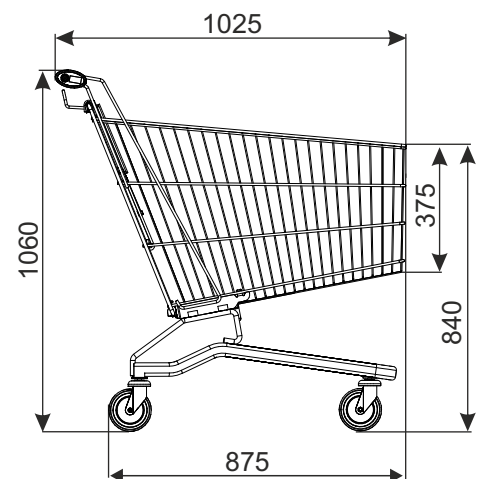

In the standard version shopping trolley has standard wheels. Optional accessories (inter alia wheels for travelator or with brake, coin lock, the logo and other accessories) require separate arrangements. Note: If you use wheels for travelator, maximum loading of the trolley is 130 kg.

PRODUCT NAME	FINISH	INDEX
Shopping trolley Classic 180F with toddler seat	zinc plated + lacquer	919-351-339

### W1 SHOPPING TROLLEYS

## SHOPPING TROLLEY CLASSIC 180FP



TYPE	Classic 180FP
BASKET CAPACITY	177 l
LOADING OF THE SHELF FOR MULTI-PACK	30 kg
LOADING	207 kg
WHEEL DIAMETER	125 mm
FINISH	zinc plated + thermal setting lacquer
NESTING DISTANCE	205 mm

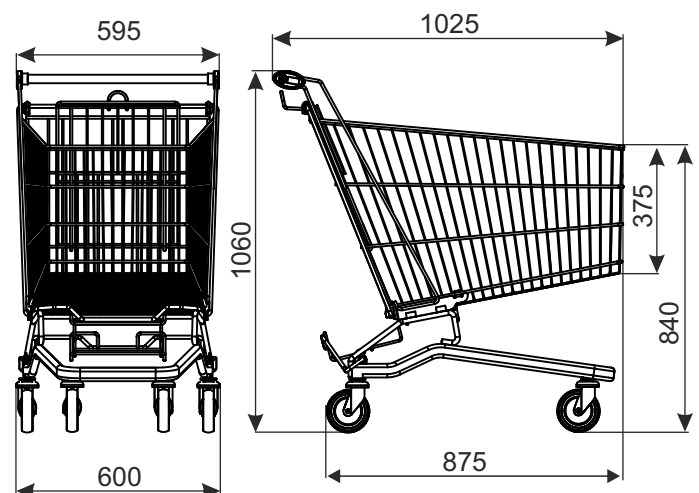

In the standard version shopping trolley has standard wheels. Optional accessories (inter alia wheels with brake, coin lock, the logo and other accessories) require separate arrangements.

PRODUCT NAME	FINISH	INDEX
Shopping trolley Classic 180FP with toddler seat	zinc plated + lacquer	919-351-339

### W1 SHOPPING TROLLEYS



## SHOPPING TROLLEY CLASSIC 180K



<b>TYPE</b>	Classic 180K
<b>BASKET CAPACITY</b>	180 l
<b>LOADING OF BASKET</b>	180 kg
<b>TOTAL LOADING</b>	230 kg
<b>WHEEL DIAMETER</b>	125 mm
<b>FINISH</b>	zinc plated + thermal setting lacquer
<b>NESTING DISTANCE</b>	220 mm

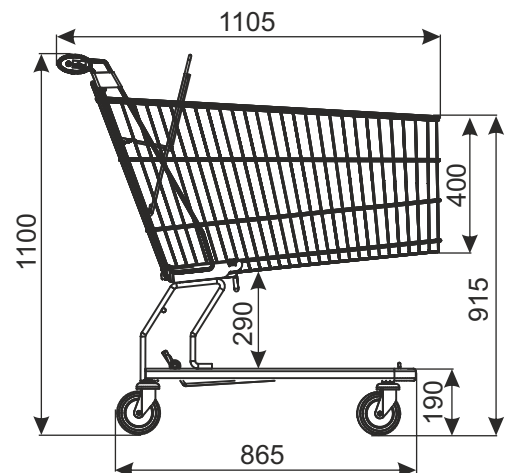

In the standard version shopping trolley has standard wheels. Optional accessories (inter alia wheels for travelator or with brake, coin lock, the logo and other accessories) require separate arrangements.  
Note: If you use wheels for travelator, maximum loading of the trolley is 130 kg.

PRODUCT NAME	FINISH	INDEX
Shopping trolley Classic 180K	zinc plated + lacquer	919-351-185

### W1 SHOPPING TROLLEYS

## SHOPPING TROLLEY CLASSIC 185



TYPE	Classic 185
BASKET CAPACITY	178 l
LOADING OF BASKET	178 kg
TOTAL LOADING	228 kg
WHEEL DIAMETER	125 mm
FINISH	zinc plated + thermal setting lacquer
NESTING DISTANCE	245 mm

In the standard version shopping trolley has standard wheels. Optional accessories (inter alia wheels for travelator or with brake, coin lock, the logo and other accessories) require separate arrangements. Note: If you use wheels for travelator, maximum loading of the trolley is 130 kg.

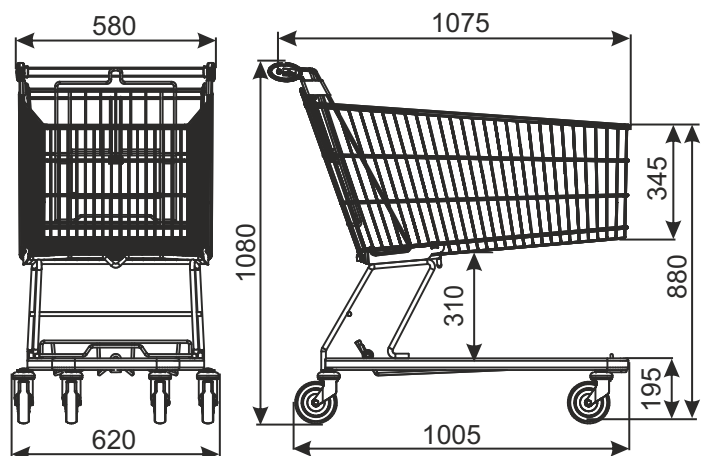

PRODUCT NAME	FINISH	INDEX
Shopping trolley Classic 185 with toddler seat	zinc plated + lacquer	919-351-134

### W1 SHOPPING TROLLEYS

## SHOPPING TROLLEY CLASSIC 185M



TYPE	Classic 185M
BASKET CAPACITY	178 l
LOADING OF BASKET	178 kg
TOTAL LOADING	228
WHEEL DIAMETER	125 mm
FINISH	zinc plated + thermal setting lacquer
NESTING DISTANCE	245 mm

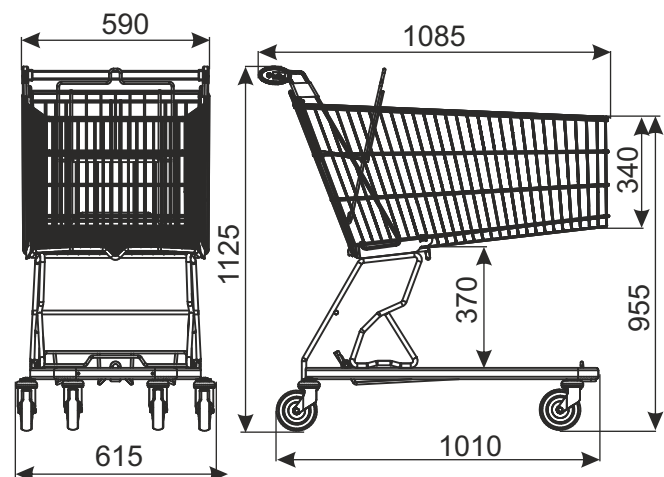

In the standard version shopping trolley has standard wheels. Optional accessories (inter alia wheels for travelator or with brake, coin lock, the logo and other accessories) require separate arrangements.  
Note: If you use wheels for travelator, maximum loading of the trolley is 130 kg.

PRODUCT NAME	FINISH	INDEX
Shopping trolley Classic 185M with toddler seat	zinc plated + lacquer	919-351-234

### W1 SHOPPING TROLLEYS

## SHOPPING TROLLEY CLASSIC 185MP (with the shelf for multi-pack)



TYPE	Classic 185MP
BASKET CAPACITY	178 l
LOADING OF BASKET	178 kg
LOADING OF THE SHELF FOR MULTI-PACK	30 kg
TOTAL LOADING	258 kg
WHEEL DIAMETER	125 mm
FINISH	zinc plated + thermal setting lacquer
NESTING DISTANCE	245 mm

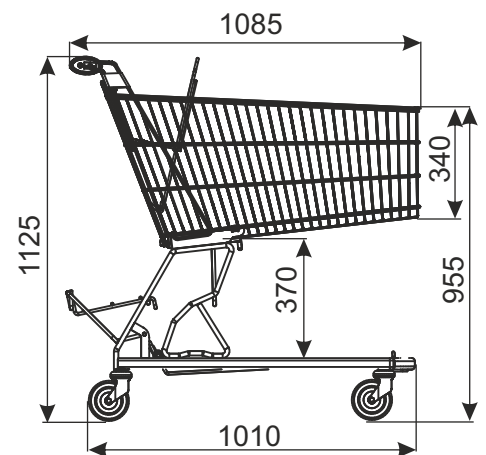
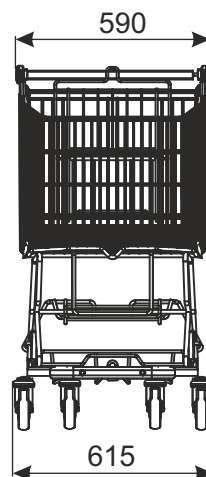

In the standard version shopping trolley has standard wheels. Optional accessories (inter alia wheels for travelator or with brake, coin lock, the logo and other accessories) require separate arrangements.  
Note: If you use wheels for travelator, maximum loading of the trolley is 130 kg.

PRODUCT NAME	FINISH	INDEX
Shopping trolley Classic 185MP with toddler seat	zinc plated + lacquer	_____

### W1 SHOPPING TROLLEYS

## SHOPPING TROLLEY CLASSIC 210A



<b>TYPE</b>	Classic 210A
<b>BASKET CAPACITY</b>	203 l
<b>LOADING</b>	203 kg
<b>WHEEL DIAMETER</b>	125 mm
<b>FINISH</b>	zinc plated + thermal setting lacquer
<b>NESTING DISTANCE</b>	250 mm

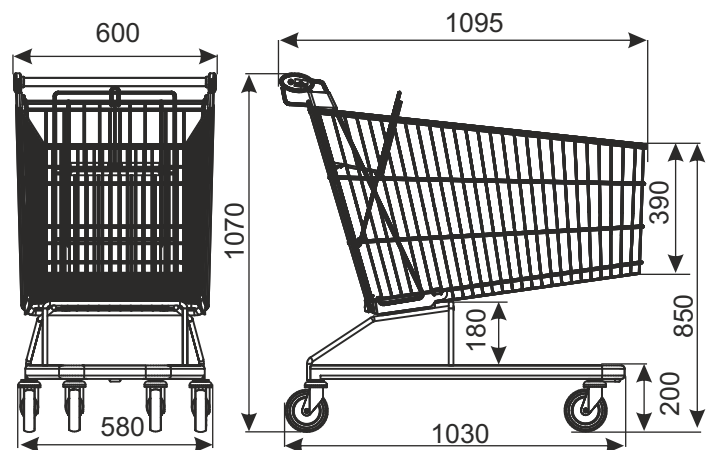

In the standard version shopping trolley has standard wheels. Optional accessories (inter alia wheels for travelator or with brake, coin lock, the logo and other accessories) require separate arrangements.  
Note: If you use wheels for travelator, maximum loading of the trolley is 130 kg.

PRODUCT NAME	FINISH	INDEX
Shopping trolley Classic 210A with toddler seat	zinc plated + lacquer	919-350-904

### W1 SHOPPING TROLLEYS

## SHOPPING TROLLEY CLASSIC 210F



<b>TYPE</b>	Classic 210F
<b>BASKET CAPACITY</b>	205 l
<b>LOADING</b>	205 kg
<b>WHEEL DIAMETER</b>	125 mm
<b>FINISH</b>	zinc plated + thermal setting lacquer
<b>NESTING DISTANCE</b>	250 mm

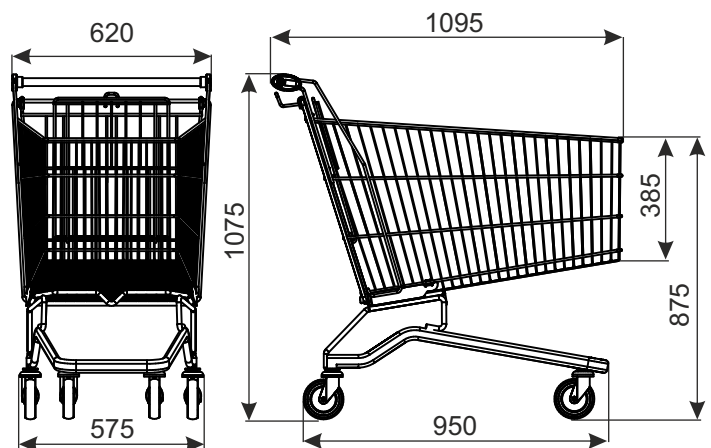

In the standard version shopping trolley has standard wheels. Optional accessories (inter alia wheels for travelator or with brake, coin lock, the logo and other accessories) require separate arrangements.  
Note: If you use wheels for travelator, maximum loading of the trolley is 130 kg.

PRODUCT NAME	FINISH	INDEX
Shopping trolley Classic 210F with toddler seat	zinc plated + lacquer	919-351-340

### W1 SHOPPING TROLLEYS

## SHOPPING TROLLEY CLASSIC 210CC

**NEW!**



<b>TYPE</b>	Classic 210CC
<b>BASKET CAPACITY</b>	203 l
<b>LOADING</b>	203 kg
<b>WHEEL DIAMETER</b>	125 mm
<b>FINISH</b>	zinc plated + thermal setting lacquer
<b>NESTING DISTANCE</b>	250 mm

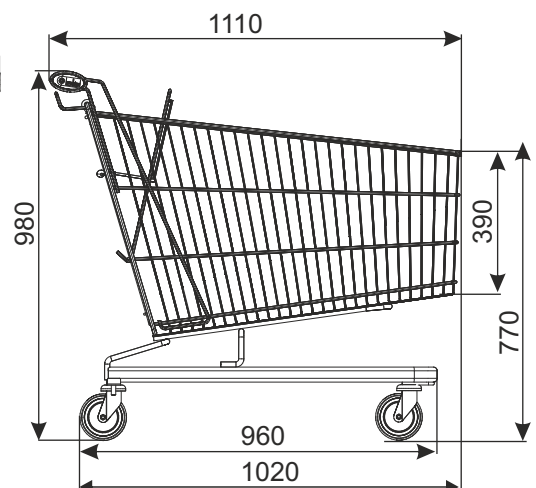
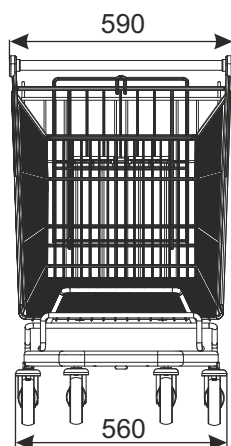

In the standard version shopping trolley has standard wheels. Optional accessories (inter alia wheels for travelator or with brake, coin lock, the logo and other accessories) require separate arrangements.  
Note: If you use wheels for travelator, maximum loading of the trolley is 130 kg.

PRODUCT NAME	FINISH	INDEX
Shopping trolley Classic 210CC with toddler seat	zinc plated + powder coating	919-351-611
Shopping trolley Classic 210CC with toddler seat	zinc plated + lacquer	—

### **W1** SHOPPING TROLLEYS

## SHOPPING TROLLEY CLASSIC 212A



TYPE	Classic 212A
BASKET CAPACITY	206 l
LOADING	206 kg
WHEEL DIAMETER	125 mm
FINISH	zinc plated + thermal setting lacquer
NESTING DISTANCE	245 mm

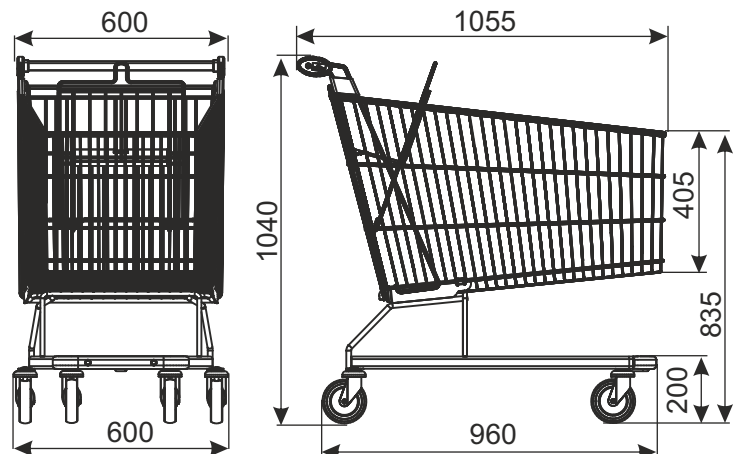

In the standard version shopping trolley has standard wheels. Optional accessories (inter alia wheels for passenger conveyors or with brake, coin lock, the logo and other accessories) require separate arrangements. Note: If you use wheels for passenger conveyors, maximum loading of the trolley is 130 kg.

PRODUCT NAME	FINISH	INDEX
Shopping trolley Classic 212A with toddler seat	zinc plated + lacquer	919-350-950

### W1 SHOPPING TROLLEYS





## SPECIAL TROLLEYS, ACCESSORIES



## **W2** SPECIAL TROLLEYS, ACCESSORIES

- 1 Shopping trolley for kids Avant P20
- 2 Shopping trolley for kids Avant MINI 20
- 3 Shopping trolley MINI 22L
- 4 Car for kids KID-CAR 110
- 5 Baby trolley Vario MOBI
- 6 Trolley for trays
- 7 Shopping trolley for wheelchair users WTN-1
- 8 Luggage trolley Vario E1
- 9 Luggage trolley Vario E2
- 10 Luggage trolley Vario G1
- 11 Order picking trolley
- 12 Service trolley with baskets
- 13 Service trolley without baskets
- 14 Trolley for two baskets Vario WKR
- 15 Trolley for two baskets Vario WKR for travelator
- 16 Trolley Vario WKR v.2 with handles for bag
- 17 Basket stacking frame (WKS-25A)
- 18 Basket stacking frame with a handle (WKS-25)
- 19 Plastic basket 20l
- 20 Plastic basket 20l new
- 21 Plastic basket 25l
- 22 Plastic basket 28l
- 23 Plastic basket 28l (R)
- 24 Plastic basket 34l on wheels, with handle
- 25 Plastic basket 40l on wheels, with handle
- 26 Plastic basket 55l on wheels, with handle
- 27 Basket "FIX" for toddler carrier
- 28 Accessories for trolleys

*The reproduce without prior permission is forbidden. In order to improve, the manufacturer reserves the right to implement modifications in its products. Recommendations for installation and use the products are provided for informational purposes only and does not imply any liability on the part of the manufacturer.*

## **W2** SPECIAL TROLLEYS, ACCESSORIES

## SHOPPING TROLLEY FOR KIDS AVANT P20



TYPE	Avant P20
BASKET CAPACITY	20 l
LOADING	20 kg
WHEEL DIAMETER	75 mm
NESTING DISTANCE	175 mm

**Standard finish:**  
zinc plated + powder coating or zinc plated+ lacquer.

### ADDITIONAL EQUIPMENT:

- mast with the handle,
- mast without the handle

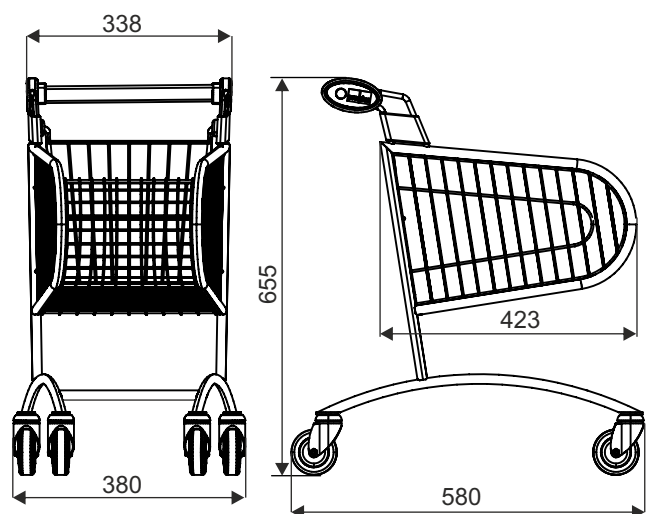

PRODUCT NAME	FINISH	INDEX
Shopping trolley for kids Avant P20	zinc plated + powder coating/ zinc plated + lacquer	919-351-155

## W2 SPECIAL TROLLEYS, ACCESSORIES

## SHOPPING TROLLEY FOR KIDS AVANT MINI 20



**Standard finish:**  
zinc plated + powder coating  
or zinc plated+ lacquer,

### ADDITIONAL EQUIPMENT:

- mast with the handle,
- mast without the handle.

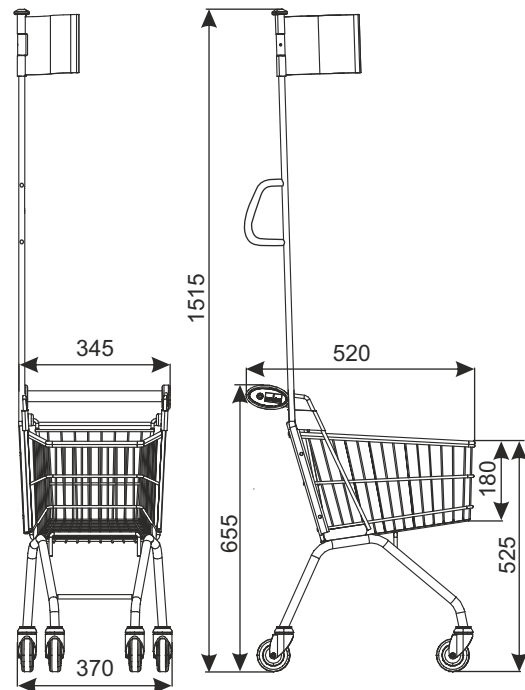

TYPE	Avant MINI 20
BASKET CAPACITY	20 l
LOADING	20 kg
WHEEL DIAMETER	75 mm
NESTING DISTANCE	180 mm

PRODUCT NAME	FINISH	INDEX
Shopping trolley for kids Avant MINI 20	zinc plated + lacquer	919-350-932

### W2 SPECIAL TROLLEYS, ACCESSORIES

## SHOPPING TROLLEY MINI 22L



Additional equipment (inter alia mast, handle Ergostick, coin lock, the logo) require separate arrangements.

TYPE	MINI 22L
BASKET CAPACITY	22 l
LOADING	22 kg
WHEEL DIAMETER	75 mm
NESTING DISTANCE	160 mm

**Standard finish:**  
zinc plated+ lacquer,

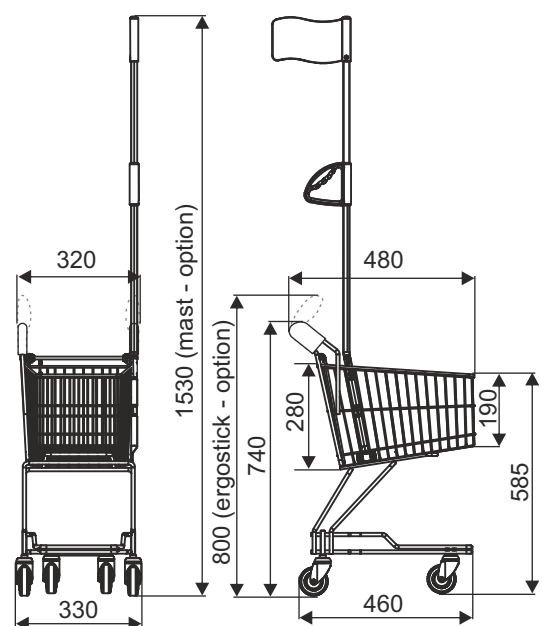

PRODUCT NAME	FINISH	INDEX
Shopping trolley MINI 22L	zinc plated + lacquer	919-351-320

### W2 SPECIAL TROLLEYS, ACCESSORIES

DAMIX Sp z o.o. ul. Bohaterów Czerwca 1956r. nr 3; PL - 87-500 Rypin  
tel. +48 54 280 34 93; fax +48 54 280 45 40; e-mail: damix@damix.pl; handel@damix.pl, www.damix.pl

All rights reserved  
27 01 2020

## CAR FOR KIDS KID-CAR 110S



Children's toy car Kid-Car 110S is the ideal solution when shopping with a child. Trolley designed for children between 2 and 5 years

TYPE	KID-CAR 110S
BASKET CAPACITY	110 l
LOADING	Basket - 75 kg, Plastic trolley - 30 kg
WHEEL DIAMETER	125 mm

Wheels with brake and seat belt is optional equipment.

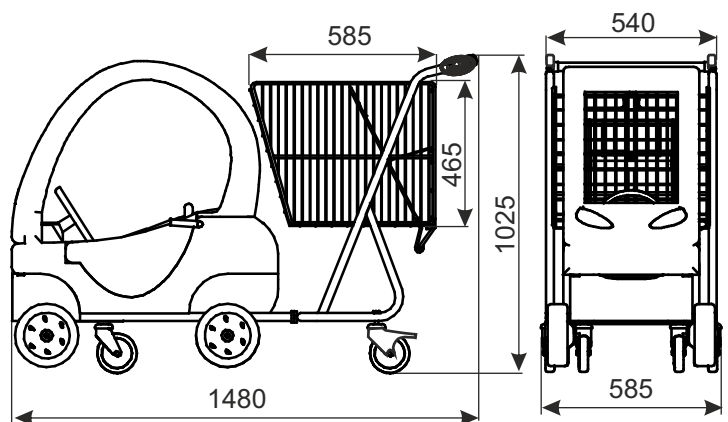

PRODUCT NAME	FINISH	INDEX
Car for kids KID-CAR 110S	basket - powder coating, trolley - plastic	919-344-040

### W2 SPECIAL TROLLEYS, ACCESSORIES

## BABY TROLLEY VARIO MOBI



<b>TYPE</b>	Baby trolley Vario MOBI
<b>LOADING</b>	15 kg
<b>WHEEL DIAMETER</b>	100 mm
<b>NESTING DISTANCE</b>	230 mm
<b>FINISH</b>	seat: galvanized zinc + powder coating frame: zinc plated + lacquer or zinc plated + powder coating

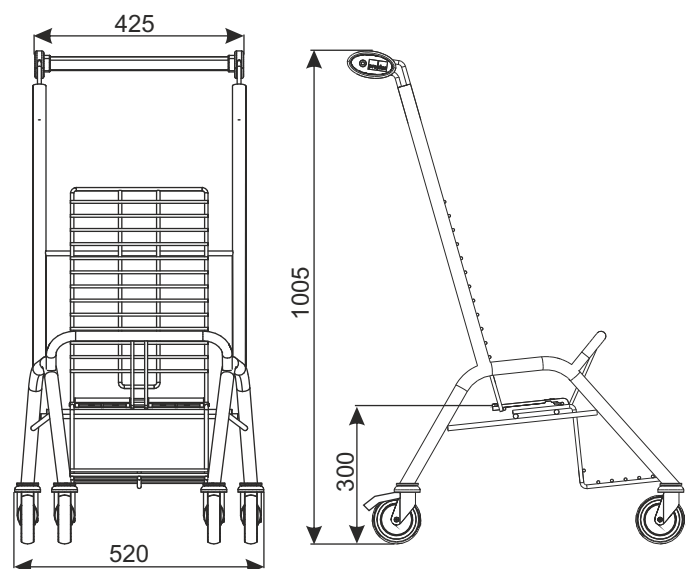

PRODUCT NAME	FINISH	INDEX
Baby trolley Vario MOBI	zinc plated + powder coating/ zinc plated + lacquer	919-350-903

### **W2** SPECIAL TROLLEYS, ACCESSORIES

## TROLLEY FOR TRAYS



**Finish:**  
zinc plated + thermal setting lacquer.

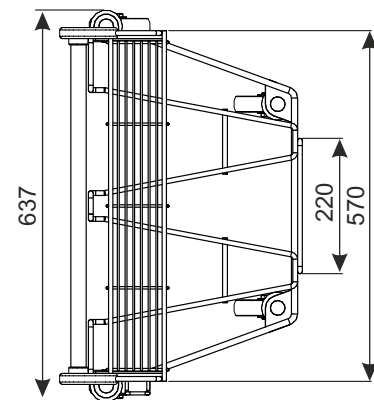
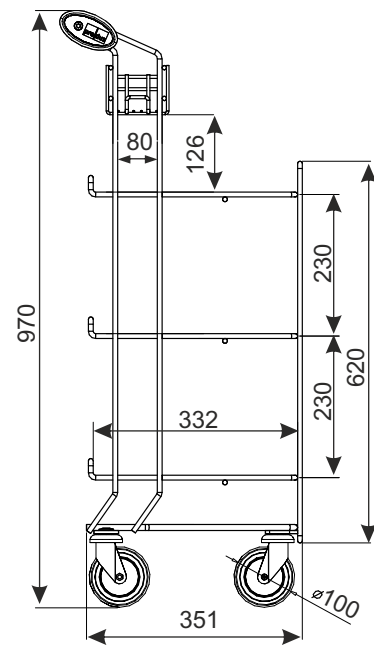

PRODUCT NAME	FINISH	INDEX
Trolley for trays	zinc plated + lacquer	919-351-236

### W2 SPECIAL TROLLEYS, ACCESSORIES

DAMIX Sp z o.o. ul. Bohaterów Czerwca 1956r. nr 3; PL - 87-500 Rypin  
tel. +48 54 280 34 93; fax +48 54 280 45 40; e-mail: damix@damix.pl; handel@damix.pl, www.damix.pl

All rights reserved  
05 03 2018



## SHOPPING TROLLEY FOR WHEELCHAIR USERS WTN-1



TYPE	WTN-1
BASKET CAPACITY	45 l
LOADING	150 kg
WHEEL DIAMETER	125 mm
NESTING DISTANCE	240 mm

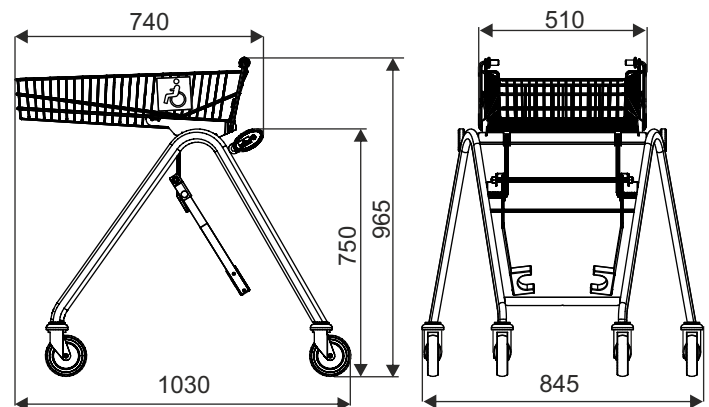

PRODUCT NAME	FINISH	INDEX
Shopping trolley for wheelchair users WTN-1	zinc plated + lacquer	919-351-189

### W2 SPECIAL TROLLEYS, ACCESSORIES

## LUGGAGE TROLLEY VARIO E1

**NEW!**



Mainly used at airports, railway stations and hotels.

**Capacity:**

Up to 4 pieces of luggages. Upper basket for handy luggage. Practical bag hook.

**Service and safety:**

High quality of protective handle (grey colour), front bumper and sloped bottom platform allow the safety of luggage. Trolley can be in option with coin lock.

**Personalization (optional):**

Advertising plate with dimensions 400x200 mm.

**Coating:**

zinc galvanized + lacquer.

Options: construction can be powder coated or made of stainless steel.

**Rollen:**

2 fixed back wheels Ø 200 mm,  
2 front swivel wheels Ø 125 mm.

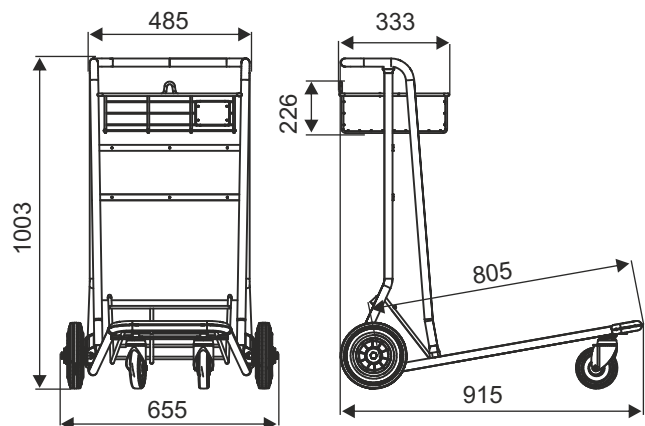

TYPE	Vario E1
TOTAL CAPACITY	250 kg
NESTING DISTANCE	340 mm

PRODUCT NAME	FINISH	INDEX
Luggage trolley Vario E1	zinc galvanized + lacquer	919-351-361

### **W2** SPECIAL TROLLEYS, ACCESSORIES

## LUGGAGE TROLLEY VARIO E2

**NEW!**



Mainly used at airports, railway stations and hotels.

**Capacity:**

Up to 4 pieces of luggages. Upper basket for handy luggage. Practical bag hook.

**Service and safety:**

High quality of protective handle (grey colour), front bumper and sloped bottom platform allow the safety of luggage.

**Personalization (optional):**

Advertising plate with dimensions 467x388 mm.

**Coating:**

zinc galvanized + lacquer.

Options: construction can be powder coated or made of stainless steel.

**Wheels:**

2 fixed back wheels Ø 200mm, 1 swivel front wheel Ø 125 mm.

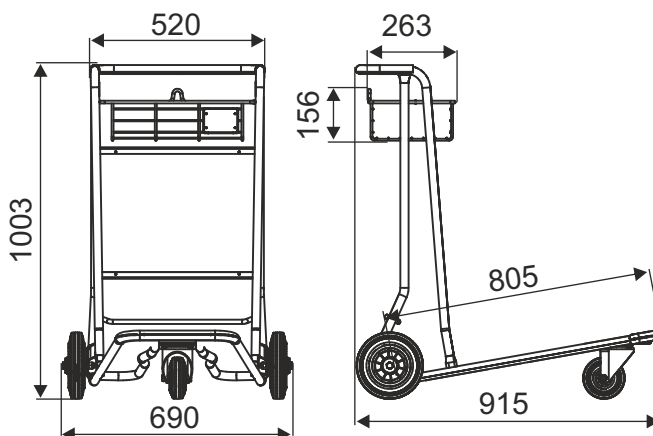

<b>TYPE</b>	Vario E2
<b>TOTAL CAPACITY</b>	250 kg
<b>NESTING DISTANCE</b>	270 mm

<b>PRODUCT NAME</b>	<b>FINISH</b>	<b>INDEX</b>
Luggage trolley Vario E2	zinc galvanized + lacquer	919-351-360

### **W2** SPECIAL TROLLEYS, ACCESSORIES

## LUGGAGE TROLLEY VARIO G1

**NEW!**



Multipurpose luggage trolley with simple braking system. Designed mainly for airports, railway stations and hotels.

<b>TYPE</b>	Vario G1
<b>LOADING</b>	250 kg
<b>WHEEL DIAMETER</b>	200 mm
<b>NESTING DISTANCE</b>	310 mm

**Load capacity:**  
250kg, up to 4 pieces of luggage.

Sloped lower platform safely holds the pieces of luggage. Upper basket for hand luggage. Practical bag hook. Front bumper. Brake system is operated by handle. Optional coin lock.

**Personalization (optional):**  
- advertising plate with dimensions 470x288 mm,  
- advertising plate on basket

**Standard finish:**  
zinc galvanized + lacquer.  
Options: construction can be powder coated or made of stainless steel.

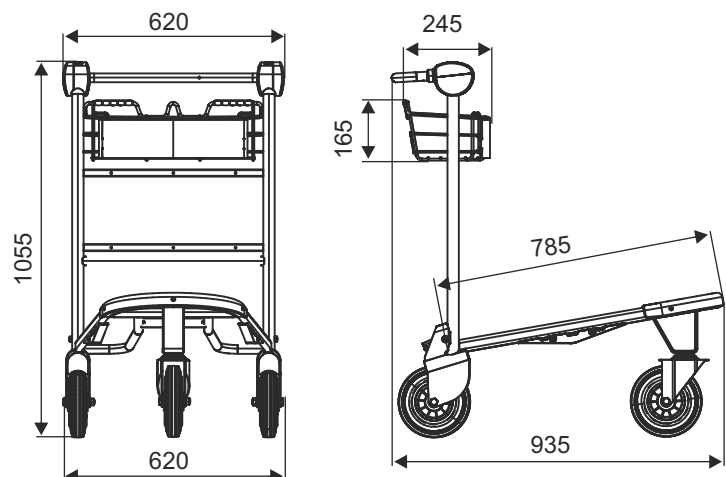

<b>PRODUCT NAME</b>	<b>FINISH</b>	<b>INDEX</b>
Luggage trolley Vario G1	zinc galvanized + lacquer	919-351-389

### **W2** SPECIAL TROLLEYS, ACCESSORIES

## ORDER PICKING TROLLEY



Trolley in combination with slide-in box for packaging. (The slide-in boxes are not included in the equipment of the trolley.)



**Finish:** zinc plated+ lacquer.

**Technical data:** the structure of the trolley is made of a section and holders made of sheet metal intended for slide-in shelves, wire basket at the top and perforated sheet metal shelf, 4 swivel castors.

**Wheel diameter:** 125 mm.

**Loading of one loading place:** 25 kg

**Total loading:** 150 kg

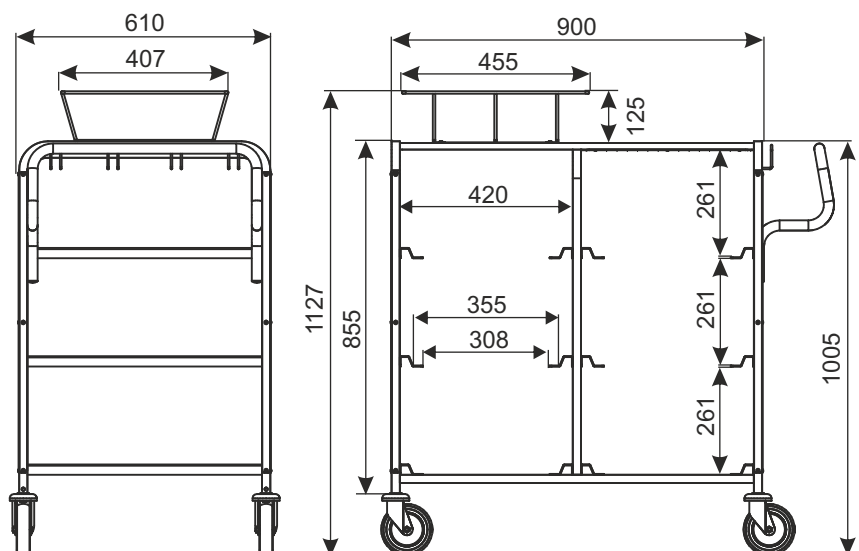

PRODUCT NAME	FINISH	INDEX
Order picking trolley	zinc plated + lacquer	919-351-067

### W2 SPECIAL TROLLEYS, ACCESSORIES

## SERVICE TROLLEY WITH BASKETS



<b>TYPE</b>	Service trolley with baskets
<b>LOADING</b>	200 kg
<b>WHEEL DIAMETER</b>	125 mm

Simple and convenient service trolley will be necessary during service work.

It allows loads up to 200kg thanks to two platforms. Swivel wheels  $\varnothing$  125mm ensure optimal maneuverability. Two fixed platforms and clipboard A4 allow convenient sorting of items and preparation of works. Corner bumpers protect the trolley and ensure durability. Two zinc baskets with dimension: length 600x width 400x height 300m.

**Standard finish:**

construction - zinc plated + powder coating  
basket - zinc plated + lacquer

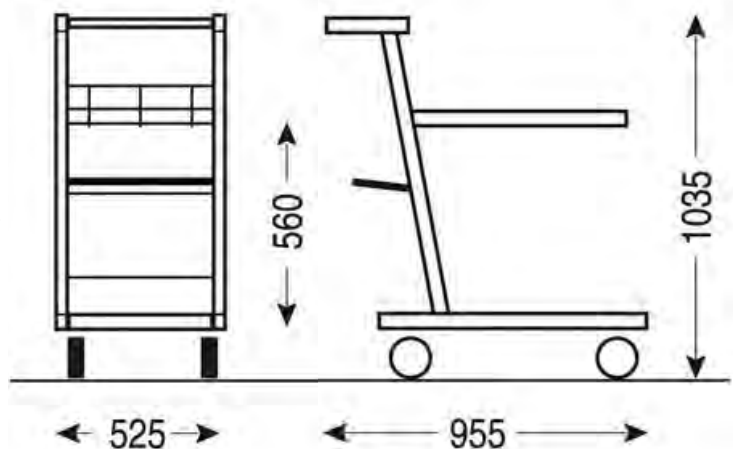

PRODUCT NAME	FINISH	INDEX
Service trolley with baskets	zinc plated + powder coating/ zinc plated + lacquer	919-351-392

### W2 SPECIAL TROLLEYS, ACCESSORIES

## SERVICE TROLLEY WITHOUT BASKETS



TYPE	Service trolley without baskets
LOADING	200 kg
WHEEL DIAMETER	125 mm

That simple and practical trolley will be necessary for service work.

The permissible loading is up to 200 kg thanks to two platforms. The construction of trolley and swivel wheels  $\varnothing$  125 mm allow optimal manoeuvrability of trolley. Two fixed platforms and clipboard A4 allow convenient way of goods' sorting and preparing of work. Corner bumpers are the protectors of trolley and they allow its stability.

**Standard finish:**  
zinc plated + powder coating.

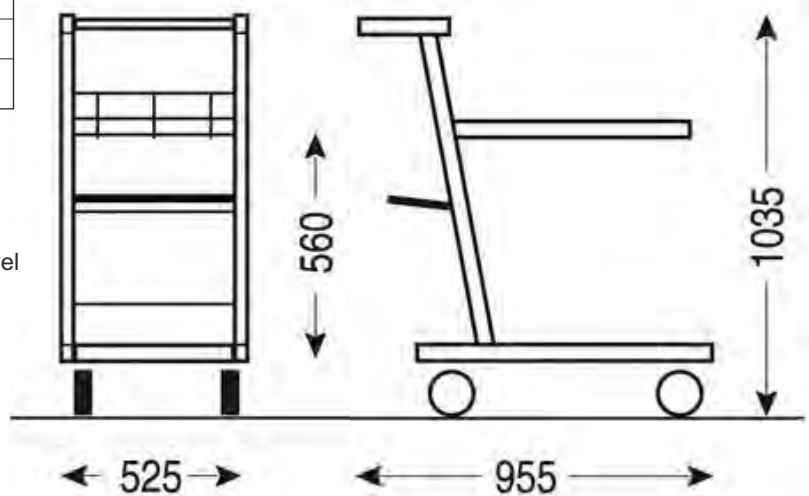

PRODUCT NAME	FINISH	INDEX
Service trolley without baskets	zinc plated + powder coating	919-351-393

### W2 SPECIAL TROLLEYS, ACCESSORIES

## TROLLEY FOR TWO BASKETS VARIO WKR XL



TYPE	Trolley for two baskets Vario WKR XL
LOADING	60 kg
WHEEL DIAMETER	75 mm lub 100 mm
NESTING DISTANCE	150 mm

Trolley is purposed for 20 l and 25 l baskets.  
(Trolley is sold without baskets.)

\* 975mm - dimension for trolley with the wheels Ø100 mm,  
950 mm - dimension for trolley with the wheels Ø75 mm

\*\* 550mm - dimension for trolley with the wheels Ø100 mm,  
525 mm - dimension for trolley with the wheels Ø75 mm.

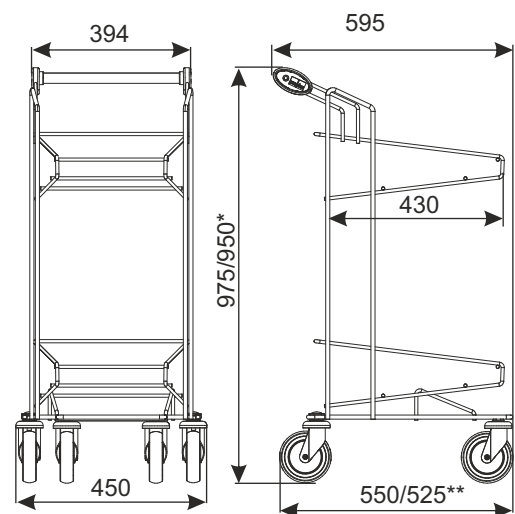

PRODUCT NAME	FINISH	INDEX
Trolley for two baskets Vario WKR XL	zinc plated + lacquer	919-351-115

### W2 SPECIAL TROLLEYS, ACCESSORIES



## TROLLEY FOR TWO BASKETS VARIO WKR XL FOR TRAVELATOR



TYPE	Trolley for two baskets Vario WKR XL for travelator
LOADING	60 kg
WHEEL DIAMETER	125 mm
NESTING DISTANCE	150 mm

Trolley is purposed for 20 l and 25 l baskets.  
 (Trolley is sold without baskets.)  
 Special wheels enable the using the trolley on travelator.  
 The fifth circle is ensuring the stability of the trolley during the convention from travelator.

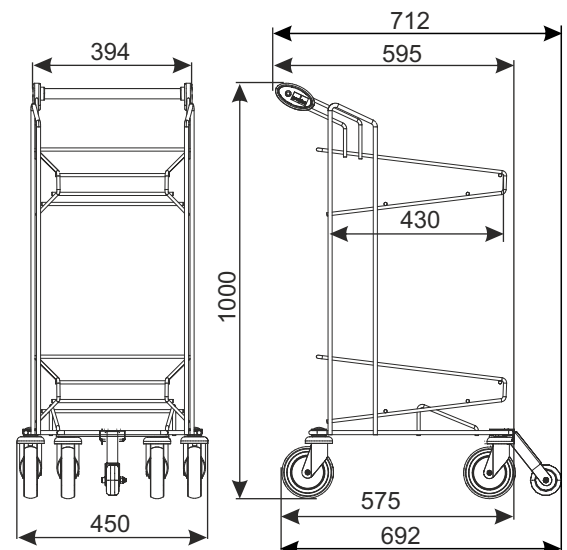

PRODUCT NAME	FINISH	INDEX
Trolley for two baskets Vario WKR for travelator	zinc plated + lacquer	—

### W2 SPECIAL TROLLEYS, ACCESSORIES

**TROLLEY VARIO WKR V.2 WITH HANDLES FOR BAG**
**NEW!**

<b>TYPE</b>	Vario WKR v.2 with handles for bag
<b>LOADING</b>	40 kg
<b>WHEEL DIAMETER</b>	75 mm
<b>NESTING DISTANCE</b>	210 mm

Trolley with wire shelf and hooks for hanging shopping bag. (The cart is sold without bags).

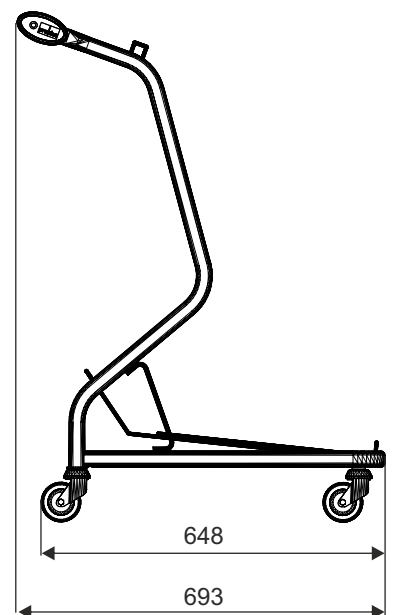
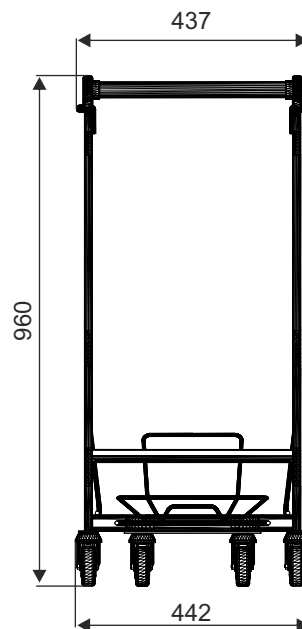

Additional equipment: phone holder.

PRODUCT NAME	FINISH	INDEX
Trolley Vario WKR v.2 with handles for bag	zinc plated + lacquer	919-351-531
Trolley Vario WKR v.2 with handles for bag	zinc plated + powder coating	-

**W2 SPECIAL TROLLEYS, ACCESSORIES**

## BASKET STACKING FRAME (WKS-25A)

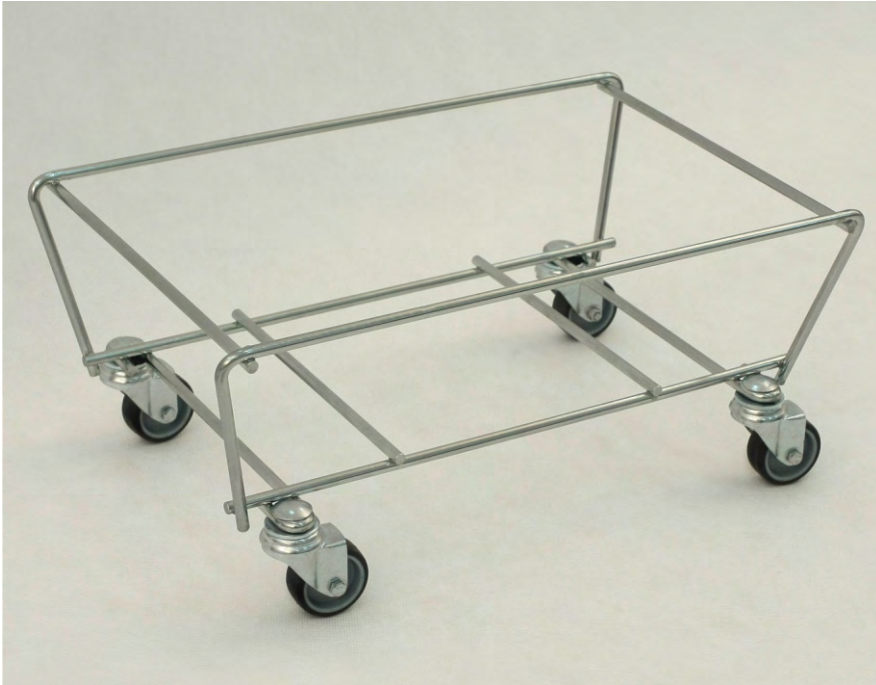

Trolley is purposed for 20 l and 25 l baskets.  
(Trolley is sold without baskets.)  
Base on wheels,  $\varnothing$  50 mm, swivel castors.

**Finish:**  
zinc plated + lacquer.  
**Loading:** 40 kg.

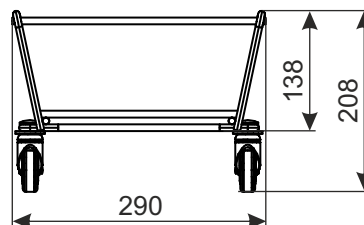
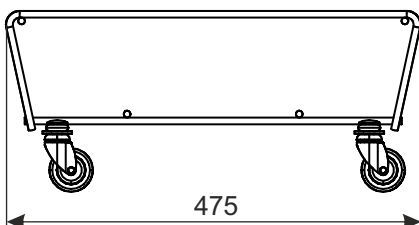

PRODUCT NAME	FINISH	INDEX
Basket stacking frame WKS-25A	zinc plated + lacquer	919-351-159

### **W2** SPECIAL TROLLEYS, ACCESSORIES

DAMIX Sp z o.o. ul. Bohaterów Czerwca 1956r. nr 3; PL - 87-500 Rypin  
tel. +48 54 280 34 93; fax +48 54 280 45 40; e-mail: damix@damix.pl; handel@damix.pl, www.damix.pl

All rights reserved  
05 03 2018

## BASKET STACKING FRAME WITH A HANDLE (WKS-25)



Trolley is purposed for 20 l and 25 l baskets.  
(Trolley is sold without baskets.)  
Base on wheels,  $\varnothing$  50 mm, swivel castors.

**Finish:**  
zinc plated + lacquer.  
**Loading:** 40 kg.

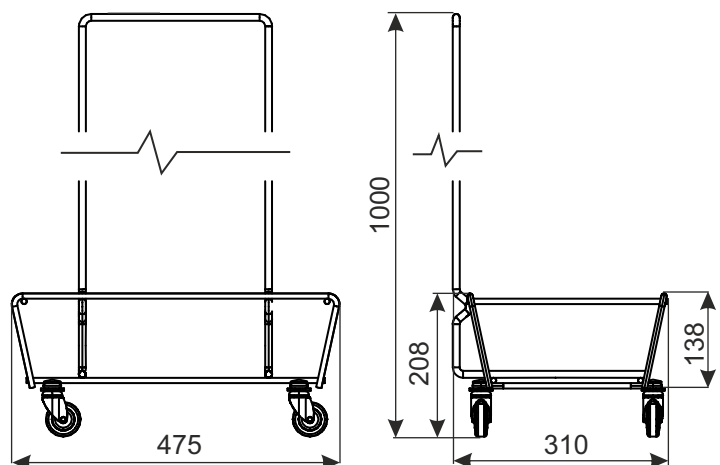

PRODUCT NAME	FINISH	INDEX
Basket stacking frame with a handle WKS-25	zinc plated + lacquer	919-351-160

### W2 SPECIAL TROLLEYS, ACCESSORIES

## PLASTIC BASKETS 20L



Baskets available with one or two, black handles.

**Standard color:**

- red,
  - blue,
  - green,
  - yellow,
  - orange,
  - black,
- (other colours to be discussed).

**Capacity:** 22l



PRODUCT NAME	FINISH	INDEX
Plastic basket 20l	plastic	KOSZ-20L

### **W2** SPECIAL TROLLEYS, ACCESSORIES

**PLASTIC BASKET 20L NEW!**



**Technical data:** Basket made of plastic.  
Baskets available with two, black handles.  
Optional sticker with the logo.

**Standard color:** red, green, blue, yellow.

**Capacity:** 20l.



PRODUCT NAME	FINISH	INDEX
Plastic basket 20l	plastic	—

**W2 SPECIAL TROLLEYS, ACCESSORIES**

## PLASTIC BASKETS 25L



Baskets available with one, black handle.

**Standard color:**

- red,
- blue,
- green.

**Capacity:** 25l



PRODUCT NAME	FINISH	INDEX
Plastic basket 25L	plastic	KOSZ-25L

### **W2** SPECIAL TROLLEYS, ACCESSORIES

## PLASTIC BASKETS 28L



**Technical data:** Basket made of plastic.  
Baskets available with two, black handles.  
Optional sticker with the logo.

**Standard color:** red, green, blue, yellow.

**Capacity:** 28 l



PRODUCT NAME	FINISH	INDEX
Plastic basket 28l	plastic	_____

### **W2** SPECIAL TROLLEYS, ACCESSORIES

DAMIX Sp z o.o. ul. Bohaterów Czerwca 1956r. nr 3; PL - 87-500 Rypin  
tel. +48 54 280 34 93; fax +48 54 280 45 40; e-mail: damix@damix.pl; handel@damix.pl, www.damix.pl

All rights reserved  
05 03 2018



## PLASTIC BASKETS 28L(R)



**Technical data:** Basket made of plastic. Baskets available with one, black handle.

**Standard color:** red, green, blue.

**Capacity:** 28 l



PRODUCT NAME	FINISH	INDEX
Plastic basket 28l (R)	plastic	KOSZ-28L(R)

### W2 SPECIAL TROLLEYS, ACCESSORIES

## PLASTIC BASKETS 34L ON WHEELS, WITH HANDLE



**Technical data:** Basket made of plastic, additional sliding handle handle with antimicrobial coating, wheels for easy movement the basket. Optional sticker with the logo.

**Standard color:**

- red,
- blue,
- green,
- black.

**Capacity:** 34l  
**Loading:** 30 kg

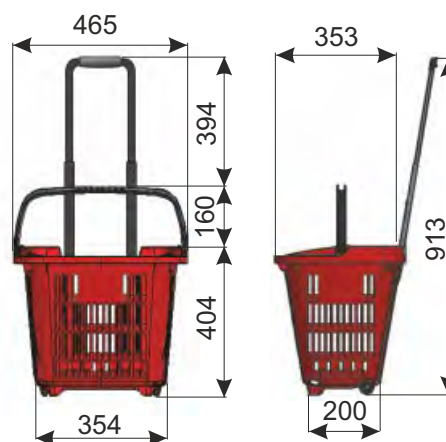

PRODUCT NAME	FINISH	INDEX
Plastic basket 34l on wheels, with handle	plastic	KOSZ_34L_KOLA

### W2 SPECIAL TROLLEYS, ACCESSORIES

## PLASTIC BASKETS 40L ON WHEELS, WITH HANDLE



**Technical data:** Basket made of plastic, additional sliding metal handle, two wheels for easy movement the basket.  
Optional sticker with the logo.  
**Standard color:** red, green, blue, yellow.  
**Capacity:** 38l

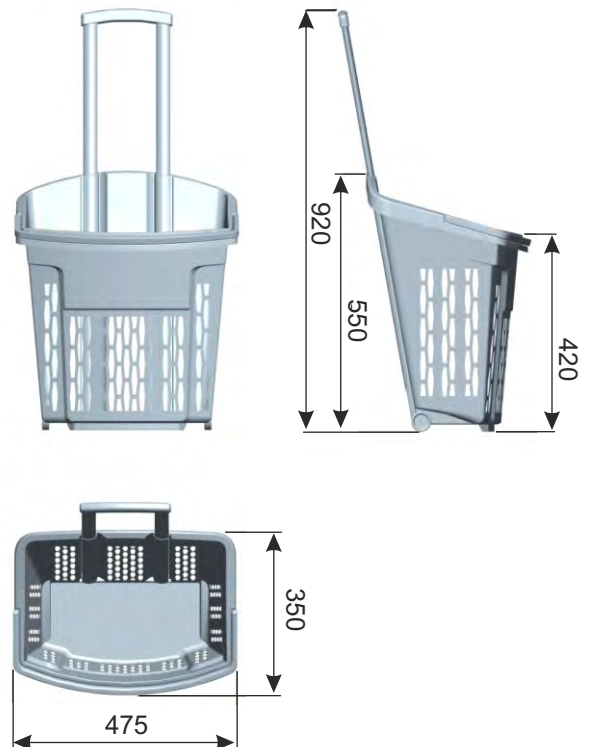

PRODUCT NAME	FINISH	INDEX
Plastic basket 40l on wheels, with handle	plastic	KOSZ_40L_KOLA

### W2 SPECIAL TROLLEYS, ACCESSORIES

DAMIX Sp z o.o. ul. Bohaterów Czerwca 1956r. nr 3; PL - 87-500 Rypin  
tel. +48 54 280 34 93; fax +48 54 280 45 40; e-mail: damix@damix.pl; handel@damix.pl, www.damix.pl

All rights reserved  
05 03 2018

## PLASTIC BASKETS 55L ON WHEELS, WITH HANDLE

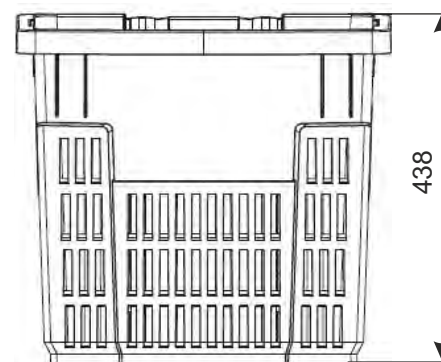
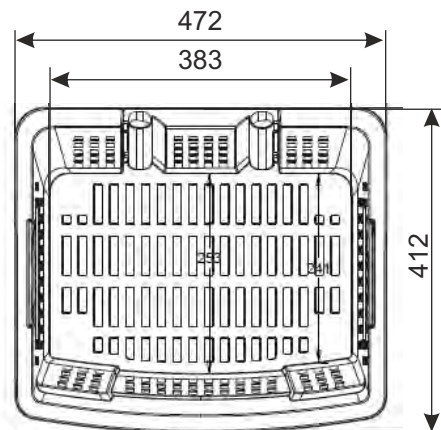

**Technical data:** Basket made of plastic, additional sliding metal handle, two wheels for easy movement the basket. Optional sticker with the logo.  
**Standard color:** red, green, blue, yellow, black.  
**Capacity:** 55l.

PRODUCT NAME	FINISH	INDEX
Plastic basket 55l on wheels, with handle	plastic	_____

### W2 SPECIAL TROLLEYS, ACCESSORIES

## BASKET "FIX" FOR TODDLER CARRIER (adjustable width of the frame with grips for trolley)



TYPE	Basket "FIX" for toddler carrier
TOTAL LOADING OF BASKET "FIX"	15 kg
MAXIMUM WEIGHT TODDLER	9 kg
FINISH	zinc plated+ thermal setting lacquer

A label with instructions for use:



Basket "FIX" for toddler carrier can be used for trolleys i.a.:

Avant 140, Avant 155, Avant 210AP, Avant 215, Avant 215AL, Classic 140, Classic 155, Classic 210A, Classic 212A.

The trolley, on which the basket for toddler carrier is mounted has to be equipped with two rear wheels with brakes.

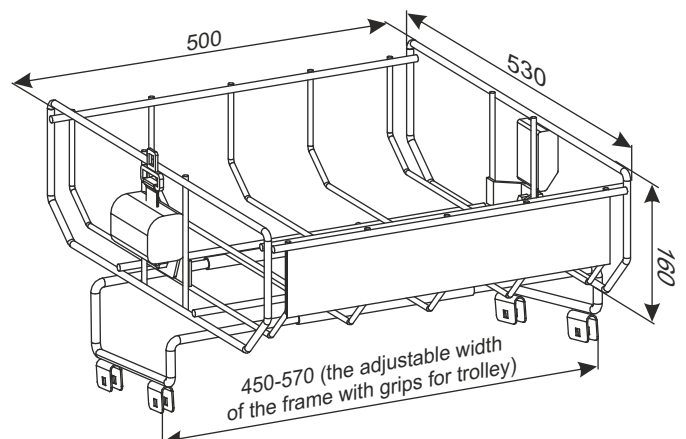

PRODUCT NAME	FINISH	INDEX
Basket "FIX" for toddler carrier	zinc plated + lacquer	919-350-881

### W2 SPECIAL TROLLEYS, ACCESSORIES

## ACCESSORIES FOR TROLLEYS

### Oval handle FG Coex Ergogrip

Available colors: yellow, blue, red, anthracite. With antistatic strip, easy way of changing the graphics, optionally with coin lock.



### Other types of handles and coin lock



handle Troleymatic with integrated lock



round handle with lock Euroloc



round handle with lock Smartloc



round handle with lock Variloc

### Plastic elements - a large range of colors



Divider for basket Avant 90  
Divider for basket Avant 140/ 215

Plastic hook

Advertising frame (for graphic 277x205 mm), two-sided

Basket for small parts to the shopping trolley

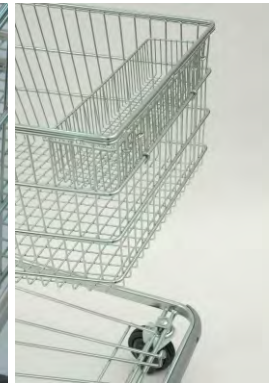

### Wheels for trolleys

Different types of wheels, mostly produced by reputable company TENTE: wheels for even surface, plastic wheels, wheels for escalator, wheels with brakes.



### Plastic protectors for basket



## W2 SPECIAL TROLLEYS, ACCESSORIES



## TRANSPORT TROLLEYS

Platform trolley is a concrete logistical proposition for the shops or garden and constructional markets. It allows for comfortable and handy transportation of purchased goods. Good constructional solutions (wooden or wire platform, variety of the size of the platform, optional top wire basket, interesting design of the bottom structure with use of round, oval or rectangular profiles, oval or round handles) make us to be up with different expectations of our Customers. Connection of ergonomic construction with aesthetic form and manufacture make shopping with our trolleys feel like pleasure.

Handles used in our shopping trolleys are adapted inter alia to the locks for coins produced by company Systec POS-technology GmbH.



## **W3** TRANSPORT TROLLEYS

- 1 Pallet P2
- 2 Transport trolley Vario Light
- 3 Transport trolley Vario Heavy
- 4 Transport trolley Vario WTP-3
- 5 Transport trolley Vario WTP-3 for travelator
- 6 Transport trolley Vario WTP-3KP
- 7 Transport trolley Vario WTP-3D
- 8 Transport trolley Vario WTP-3A
- 9 Transport trolley Vario WTP4
- 10 Transport trolley Vario 70 PN-1
- 11 Transport trolley Vario 90
- 12 Transport trolley Vario 90S
- 13 Transport trolley Vario 110
- 14 Transport trolley Vario 110S
- 15 Transport trolley Vario 110PK
- 16 Transport trolley Vario 115 with folded basket
- 17 Transport trolley Vario 115 with fixed basket
- 18 Transport trolley Vario 115 with additional set
- 19 Transport trolley Vario 120
- 20 Transport trolley Vario 120S
- 21 Transport trolley Vario 125
- 22 Transport trolley Vario 125M
- 23 Transport trolley Carry 80
- 24 Transport trolley Carry 90
- 25 Transport trolley Carry 90 for travelator
- 26 Transport trolley Carry 95
- 27 Transport trolley Carry 100
- 28 Transport trolley Carry 100 for travelator
- 29 Transport trolley Carry 100ZR
- 30 Transport trolley Carry 120
- 31 Transport trolley Carry 120M
- 32 Transport trolley Carry 160
- 33 Transport trolley Carry 160 with the fifth wheel
- 34 Panel transporter Carry WP1A
- 35 Panel transporter Carry WP1B
- 36 Panel transporter Carry WP3
- 37 Panel transporter Carry WP3B
- 38 Panel transporter Carry WP6B
- 39 Panel transporter Carry WP4
- 40 Panel transporter Carry WP4A
- 41 Panel transporter Carry WP4BW
- 42 Panel transporter Carry WP5
- 43 Single-axle carriage for panels
- 44 Trolley for fence panels

*The reproduce without prior permission is forbidden. In order to improve, the manufacturer reserves the right to implement modifications in its products. Recommendations for installation and use the products are provided for informational purposes only and does not imply any liability on the part of the manufacturer.*

## **W3** TRANSPORT TROLLEYS



## PALLET P2-1100X600



TYPE	Pallet P2-1100x600
LOADING	400 kg
WHEEL DIAMETER	160 mm

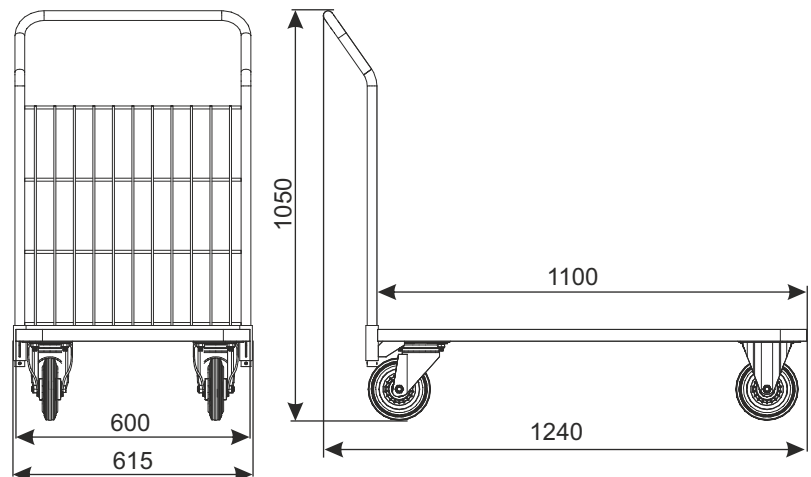

PRODUCT NAME	FINISH	INDEX
Pallet P2-1100x600	zinc plated+lacquer	919-351-207

### W3 TRANSPORT TROLLEYS

## TRANSPORT TROLLEY VARIO LIGHT



TYPE	Vario Light
LOADING OF THE UPPER SHELF	100 kg
TOTAL LOADING	300 kg
WHEEL DIAMETER	125 mm
NESTING DISTANCE	270 mm

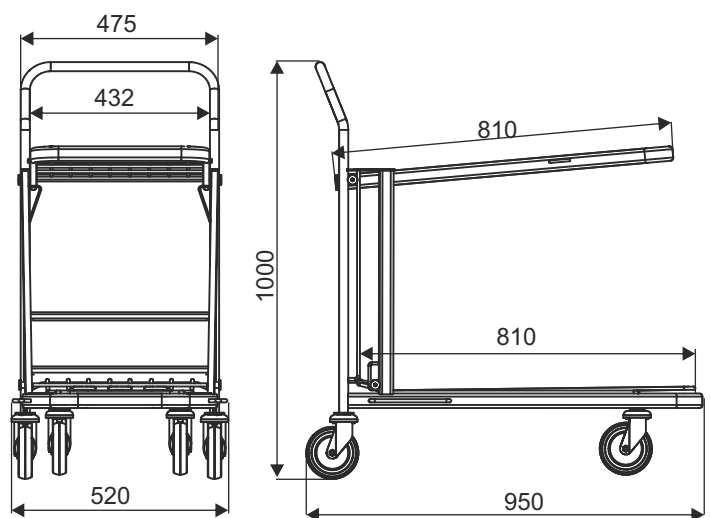

PRODUCT NAME	FINISH	INDEX
Transport trolley Vario Light	zinc plated+lacquer	919-351-474

### W3 TRANSPORT TROLLEYS

## TRANSPORT TROLLEY VARIO HEAVY

**NEW!**



<b>TYPE</b>	Vario Heavy
<b>TOTAL LOADING</b>	200 kg
<b>WHEEL DIAMETER</b>	125 mm
<b>NESTING DISTANCE</b>	300 mm

The automatically lowering shelf as the load increases and the possibility of folding it increases the loading comfort and allows for ergonomic use of the loading area of the trolley. The trolley has 4 swivel castors, including 2 with a brake.

**Standard finish:**  
zinc plated+lacquer.

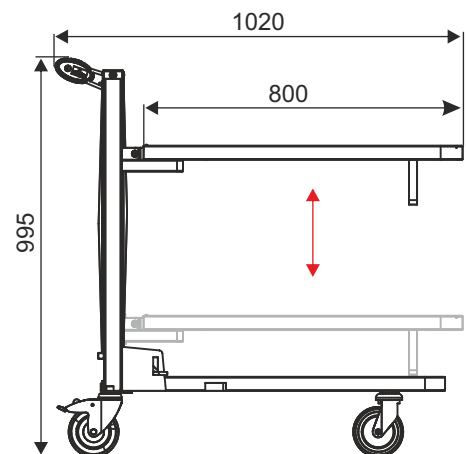
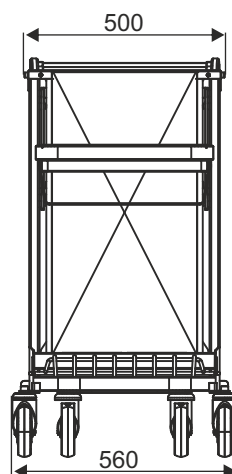

PRODUCT NAME	FINISH	INDEX
Transport trolley Vario Heavy	zinc plated+lacquer	919-351-423

### **W3** TRANSPORT TROLLEYS

## TRANSPORT TROLLEY VARIO WTP-3



TYPE	Vario WTP-3
BASKET CAPACITY	45 l
LOADING OF BASKET	45 kg
TOTAL LOADING	300 kg
WHEEL DIAMETER	125 mm
NESTING DISTANCE	285 mm

In the standard version shopping trolley has standard wheels. Optional accessories (inter alia wheels with brake, coin lock, logo and other accessories) require separate arrangements.

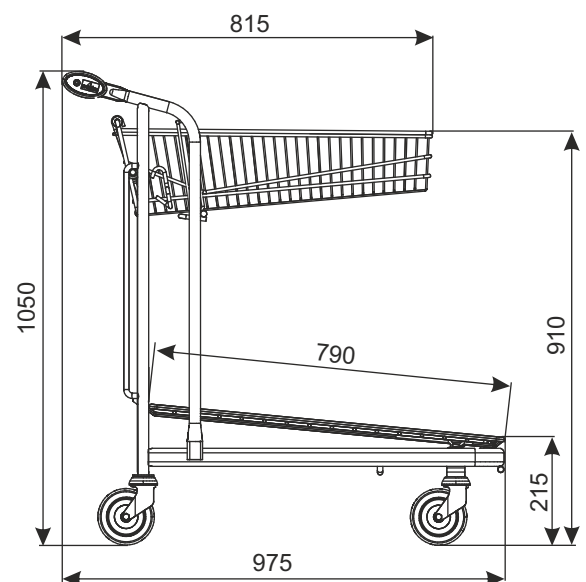
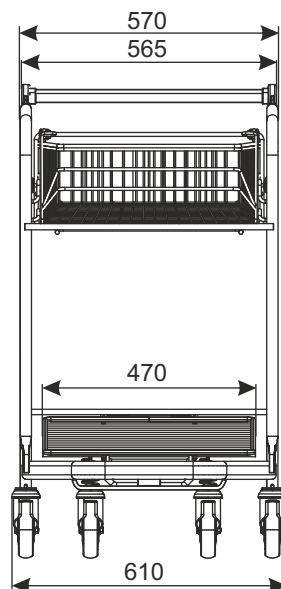

PRODUCT NAME	FINISH	INDEX
Transport trolley Vario WTP-3	zinc plated + lacquer	919-351-129

### W3 TRANSPORT TROLLEYS

## TRANSPORT TROLLEY VARIO WTP-3 FOR TRAVELATOR



TYPE	Vario WTP-3 for travelator
BASKET CAPACITY	45 l
LOADING OF BASKET	45 kg
TOTAL LOADING	130 kg
WHEEL DIAMETER	125 mm
NESTING DISTANCE	285 mm

The trolley has wheels for travelator and front stop barrier. Optional accessories (inter alia coin lock, logo and other accessories) require separate arrangements.

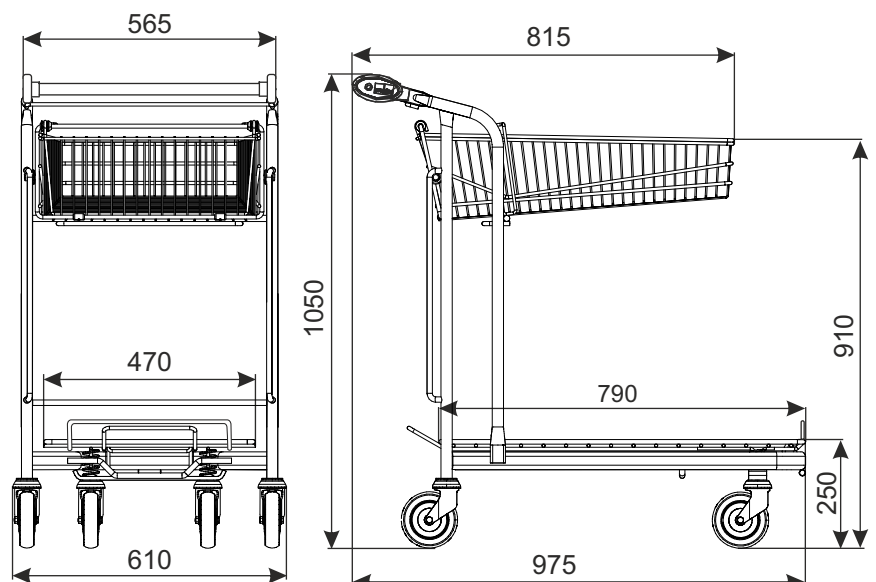

PRODUCT NAME	FINISH	INDEX
Transport trolley Vario WTP-3 for travelator	zinc plated + lacquer	919-351-129

### W3 TRANSPORT TROLLEYS

## TRANSPORT TROLLEY VARIO WTP-3KP (with the shelf and the basket)



TYPE	Vario WTP-3KP
BASKET CAPACITY	20 l
LOADING OF BASKET	20 kg
LOADING OF SHELF	20 kg
TOTAL LOADING	300 kg
WHEEL DIAMETER	125 mm
NESTING DISTANCE	390 mm

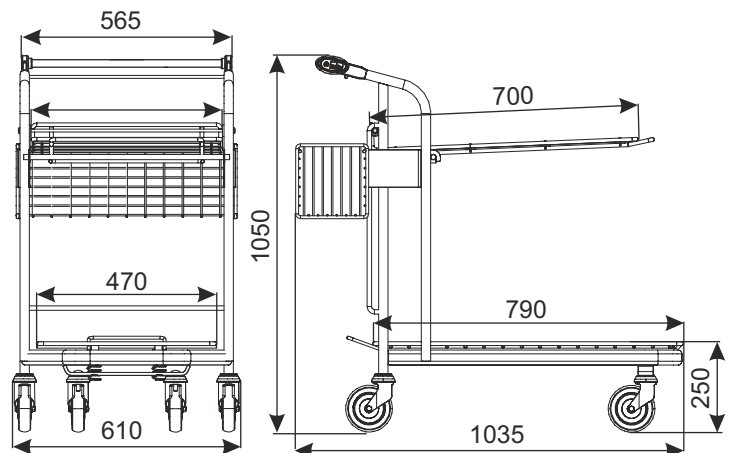

In the standard version shopping trolley has standard wheels. Optional accessories (inter alia wheels with brake, coin lock, logo and other accessories) require separate arrangements.

PRODUCT NAME	FINISH	INDEX
Transport trolley Vario WTP-3KP	zinc plated+lacquer	919-351-129_KP

### W3 TRANSPORT TROLLEYS

## TRANSPORT TROLLEY VARIO WTP-3D (with wire shelf)



TYPE	Vario WTP-3D
LOADING OF BASKET	20 kg
TOTAL LOADING	300 kg
WHEEL DIAMETER	125 mm
NESTING DISTANCE	285 mm

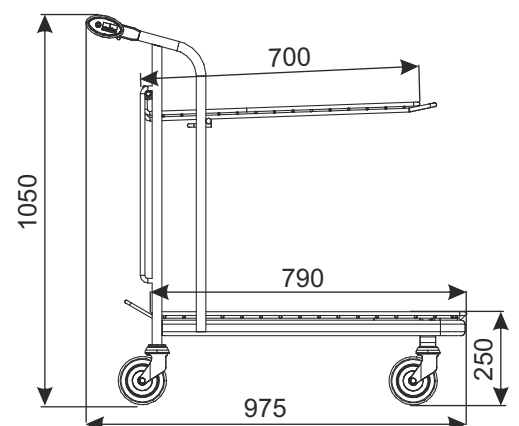
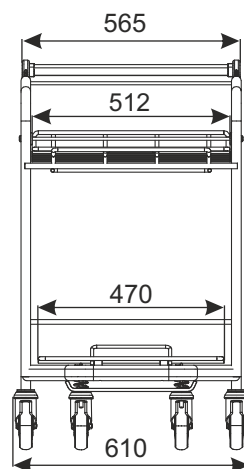

In the standard version shopping trolley has standard wheels. Optional accessories (inter alia wheels with brake, coin lock, logo and other accessories) require separate arrangements.

PRODUCT NAME	FINISH	INDEX
Transport trolley Vario WTP-3D	zinc plated+lacquer	—

### W3 TRANSPORT TROLLEYS

## TRANSPORT TROLLEY VARIO WTP-3A



TYPE	Vario WTP-3A
BASKET CAPACITY	45 l
LOADING OF BASKET	45 kg
LOADING OF ADDITIONAL SIDE SET	50 kg
TOTAL LOADING	300 kg
WHEEL DIAMETER	125 mm
NESTING DISTANCE	285 mm

The additional set mounted on the side of the trolley is intended for transport of a long items with dimensions not exceeding 1000mm in height and 2400mm in length, ie tubes, strips, boards, doors.

**Standard finish:** galvanized zinc,

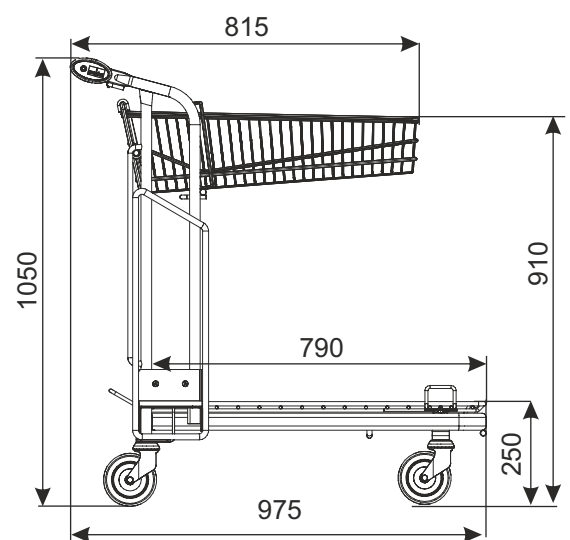
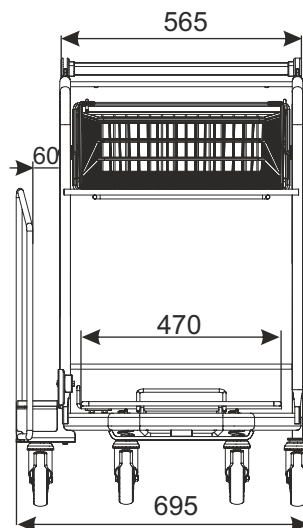

In the standard version shopping trolley has standard wheels. Optional accessories (inter alia wheels with brake, coin lock, logo and other accessories) require separate arrangements.

PRODUCT NAME	FINISH	INDEX
Transport trolley Vario WTP-3A	zinc plated+lacquer	_____

### W3 TRANSPORT TROLLEYS



## TRANSPORT TROLLEY VARIO WTP4

**NEW!**

The trolley has a wire platform, a lower basket and an upper basket. The upper basket can be lifted upwards, which allows to increase the loading area of the wire platform. The mounted actuator prevents the basket from falling spontaneously.

**Standard finish:** zinc plated+lacquer.



<b>TYPE</b>	Vario WTP4
<b>LOADING OF THE UPPER BASKET</b>	80 kg
<b>LOADING OF THE LOWER BASKET</b>	20 kg
<b>CAPACITY OF THE LOWER BASKET</b>	13 L
<b>TOTAL LOADING</b>	200 kg
<b>WHEEL DIAMETER</b>	125 mm
<b>NESTING DISTANCE</b>	300 mm

**Optional equipment:**

- the fifth wheel

- Side handle for the coin lock

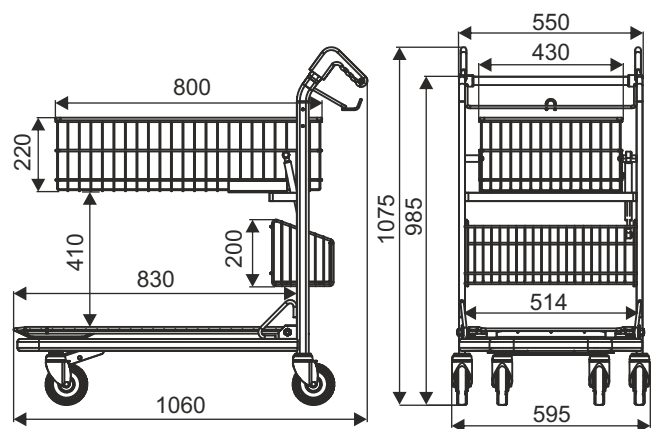

In the standard version shopping trolley has standard wheels. Optional accessories (inter alia wheels with brake, coin lock, logo and other accessories) require separate arrangements.

<b>PRODUCT NAME</b>	<b>FINISH</b>	<b>INDEX</b>
Transport trolley Vario WTP4	zinc plated + lacquer	919-351-536

### W3 TRANSPORT TROLLEYS

## TRANSPORT TROLLEY VARIO 70 (PN-1)



TYPE	Vario 70 (PN-1)
BASKET CAPACITY	18 l
LOADING OF BASKET	20 kg
TOTAL LOADING	300 kg
WHEEL DIAMETER	125 mm
NESTING DISTANCE	250 mm

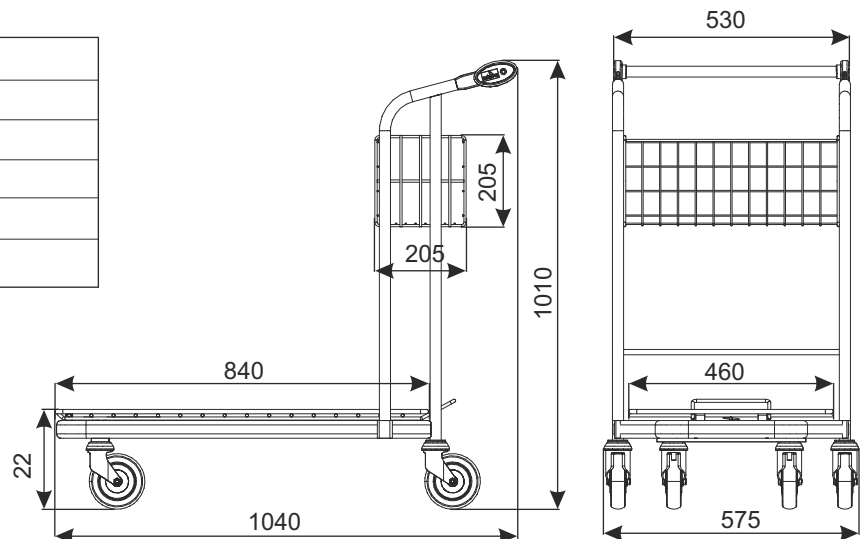

PRODUCT NAME	FINISH	INDEX
Transport trolley Vario 70 (PN-1)	zinc plated+lacquer	919-351-216

### W3 TRANSPORT TROLLEYS

## TRANSPORT TROLLEY VARIO 90



wire platform

<b>TYPE</b>	Vario 90
<b>BASKET CAPACITY</b>	32 l
<b>LOADING OF BASKET</b>	32 kg
<b>TOTAL LOADING</b>	300 kg
<b>WHEEL DIAMETER</b>	125 mm
<b>NESTING DISTANCE</b>	270 mm

**Trolley is available in the option:**

- with the wire platform,
- with full platform ( platform of plywood, anti-slip, waterproof, double-sided foiled).

**Standard finish:**

zinc plated, sides are additionally powder coated, what enriches the aesthetics of the trolley and composes with color scheme of the shop.

In the standard version shopping trolley has standard wheels. Optional accessories (inter alia wheels with brake, coin lock, logo and other accessories) require separate arrangements.



full platform

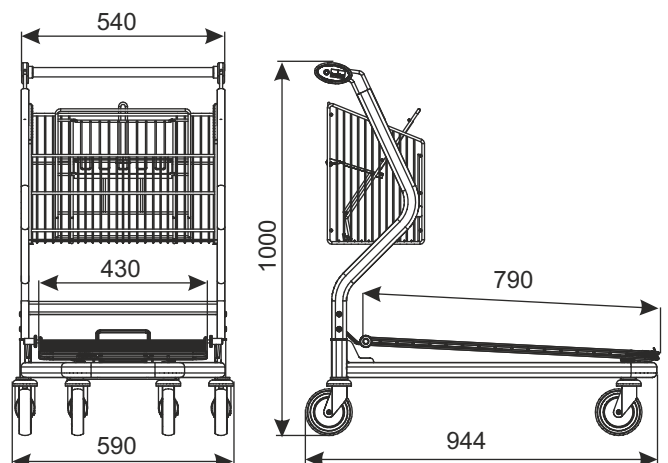

<b>PRODUCT NAME</b>	<b>FINISH</b>	<b>INDEX</b>
Transport trolley Vario 90	zinc plated/powder coated	919-350-725

### W3 TRANSPORT TROLLEYS

## TRANSPORT TROLLEY VARIO 90S (with folded basket)



TYPE	Vario 90S
BASKET CAPACITY	30 l (folded basket) 55 l (unfolded basket)
LOADING OF BASKET	40 kg
TOTAL LOADING	300 kg
WHEEL DIAMETER	125 mm
NESTING DISTANCE	270 mm

### Standard finish:

zinc plated, sides are additionally powder coated, what enriches the aesthetics of the trolley and composes with color scheme of the shop.

### Trolley is available in the option:

- with the wire platform,
- with full platform ( platform of plywood, anti-slip, waterproof, double-sided foiled).

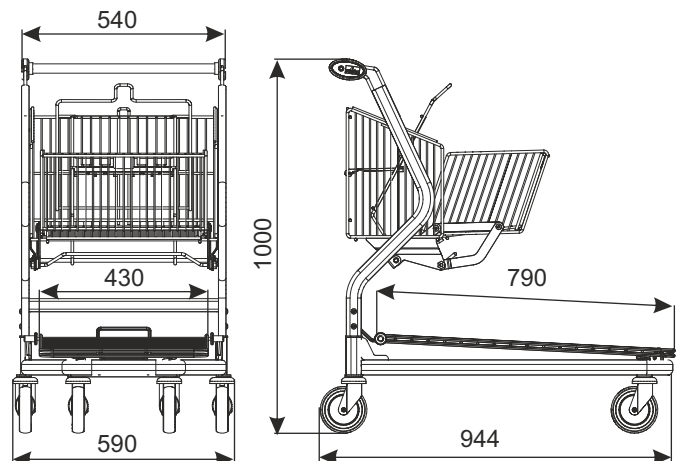

In the standard version shopping trolley has standard wheels. Optional accessories (inter alia wheels with brake, coin lock, logo and other accessories) require separate arrangements.



PRODUCT NAME	FINISH	INDEX
Transport trolley Vario 90S	zinc plated/powder coated	919-350-750

## W3 TRANSPORT TROLLEYS

## TRANSPORT TROLLEY VARIO 110



TYPE	Vario 110
BASKET CAPACITY	37 l
LOADING OF BASKET	37 kg
TOTAL LOADING	300 kg
WHEEL DIAMETER	125 mm
NESTING DISTANCE	280 mm

**Trolley is available in the option:**

- with the wire platform,
- with full platform ( platform of plywood, anti-slip, waterproof, double-sided foiled).

**Standard finish:**

zinc plated, sides are additionally powder coated, what enriches the aesthetics of the trolley and composes with color scheme of the shop.

In the standard version shopping trolley has standard wheels. Optional accessories (inter alia wheels with brake, coin lock, logo and other accessories) require separate arrangements.

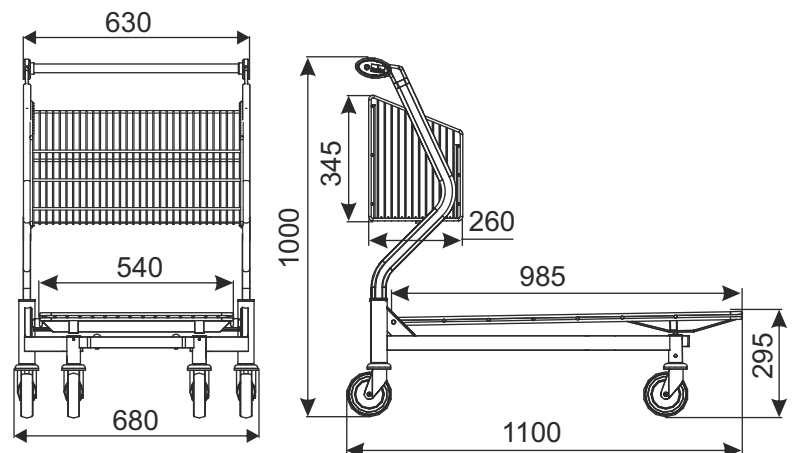

PRODUCT NAME	FINISH	INDEX
Transport trolley Vario 110	zinc plated/powder coated	919-350-746

### W3 TRANSPORT TROLLEYS

## TRANSPORT TROLLEY VARIO 110S (with folded basket)



TYPE	Vario 110S
BASKET CAPACITY	40 l (folded basket) 65 l (unfolded basket)
LOADING OF BASKET	40 kg
TOTAL LOADING	300 kg
WHEEL DIAMETER	125 mm
NESTING DISTANCE	280 mm

### Trolley is available in the option:

- with the wire platform,
- with full platform ( platform of plywood, anti-slip, waterproof, double-sided foiled).

### Standard finish:

zinc plated, sides are additionally powder coated, what enriches the aesthetics of the trolley and composes with color scheme of the shop.

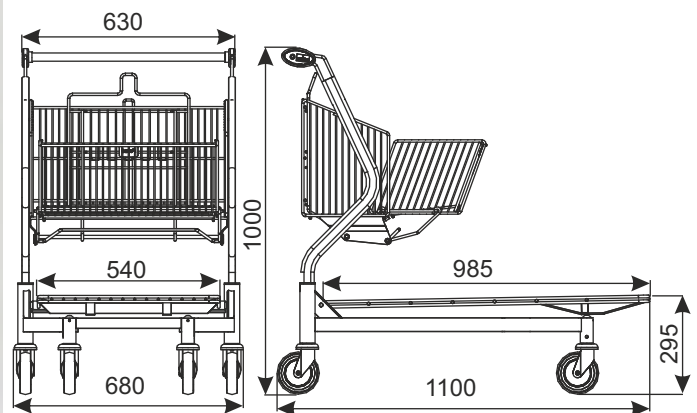

*unfolded basket*

*folded basket*



In the standard version shopping trolley has standard wheels. Optional accessories (inter alia wheels with brake, coin lock, logo and other accessories) require separate arrangements.

PRODUCT NAME	FINISH	INDEX
Transport trolley Vario 110S (wooden platform)	zinc plated/powder coated	919-350-780
Transport trolley Vario 110S (wire platform)	zinc plated/powder coated	919-350-751

## W3 TRANSPORT TROLLEYS

## TRANSPORT TROLLEY VARIO 110PK



As a standard is the trolley with one front bar ( mounted to the platform).

TYPE	Vario 110PK
BASKET CAPACITY	15 l
LOADING OF BASKET	15 kg
TOTAL LOADING	300 kg
WHEEL DIAMETER	125 mm
NESTING DISTANCE	275 mm

### Standard finish:

zinc plated, sides are additionally powder coated, what enriches the aesthetics of the trolley and composes with color scheme of the shop.

### ADDITIONAL EQUIPMENT:

In the standard version shopping trolley has standard wheels. Optional accessories (inter alia wheels with brake, coin lock, logo and other accessories) require separate arrangements.

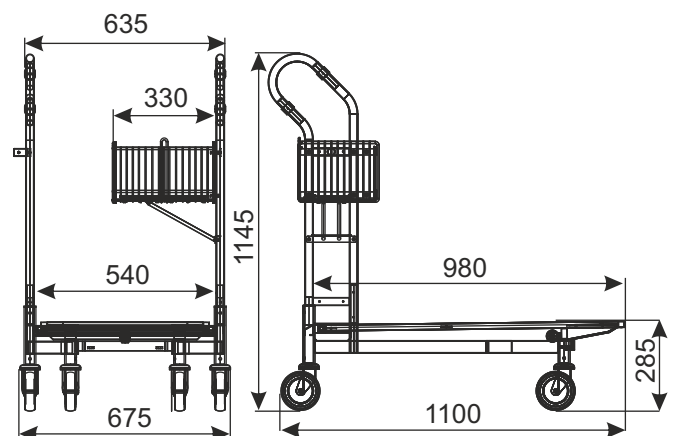

PRODUCT NAME	FINISH	INDEX
Transport trolley Vario 110PK	zinc plated/powder coated	919-350-900

## W3 TRANSPORT TROLLEYS

## TRANSPORT TROLLEY VARIO 115 with folded basket

**NEW!**



### Optional equipment:

- full platform ( platform of plywood, anti-slip, waterproof, double-sided foiled).



<b>TYPE</b>	Vario 115 (with folded basket)
<b>BASKET CAPACITY</b>	45l/ 75l
<b>LOADING OF BASKET</b>	50 kg
<b>TOTAL LOADING</b>	250 kg
<b>WHEEL DIAMETER</b>	125 mm
<b>NESTING DISTANCE</b>	360 mm



In the standard version shopping trolley has standard wheels. Optional accessories (inter alia wheels for travelator or with brake, coin lock, logo and other accessories) require separate arrangements.

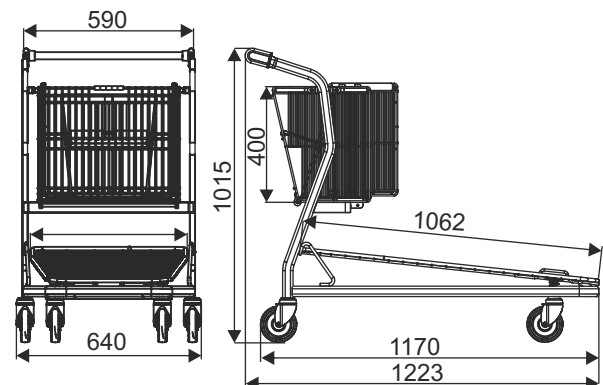

<b>PRODUCT NAME</b>	<b>FINISH</b>	<b>INDEX</b>
Transport trolley Vario 115 (with folded basket)	zinc plated + lacquer	919-351-449

### **W3** TRANSPORT TROLLEYS



## TRANSPORT TROLLEY VARIO 115 with fixed basket

**NEW!**



TYPE	Vario 115 (with fixed basket)
BASKET CAPACITY	50 l
LOADING OF BASKET	50 kg
TOTAL LOADING	250 kg
WHEEL DIAMETER	125 mm
NESTING DISTANCE	360 mm

### Optional equipment:

#### - fifth wheel

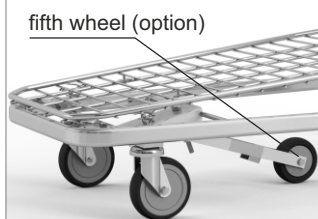

#### - set for travelator (wheels for travelator and front stop barrier)

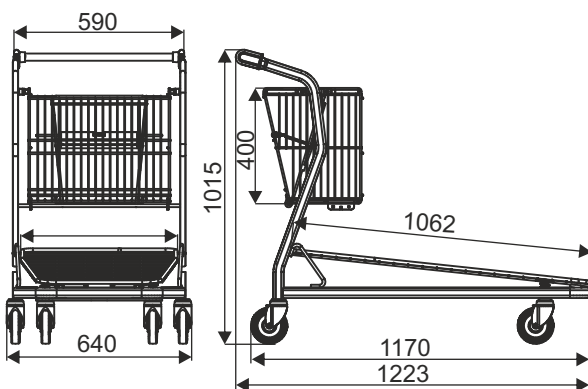
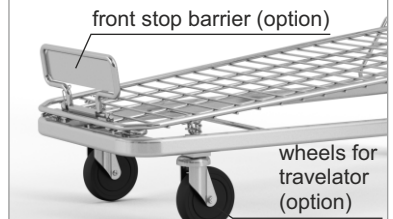

In the standard version shopping trolley has standard wheels. Optional accessories (inter alia wheels for travelator or with brake, coin lock, logo and other accessories) require separate arrangements.

#### - full platform ( platform of plywood, anti-slip, waterproof, double-sided foiled).

#### full platform (option)



PRODUCT NAME	FINISH	INDEX
Transport trolley Vario 115 (with fixed basket) with toddler seat	zinc plated + lacquer	_____
Transport trolley Vario 115 (with fixed basket) without toddler seat	zinc plated + lacquer	_____

## W3 TRANSPORT TROLLEYS

## TRANSPORT TROLLEY VARIO 115 with additional set



The additional set mounted on the side of the trolley is intended for transport of items with dimensions not exceeding 1000mm in height and 2400mm in length, i.e.: tubes, strips, boards, doors

The trolley is available in several variants:

*with fixed basket  
with toddler seat*

*with fixed basket  
without toddler seat*

*with folded basket*

Basket:

- folded,
- fixed with toddler seat,
- fixed without toddler seat.

Platform:

- wire,
- full (platform of plywood, anti-slip, waterproof, double-sided foiled).

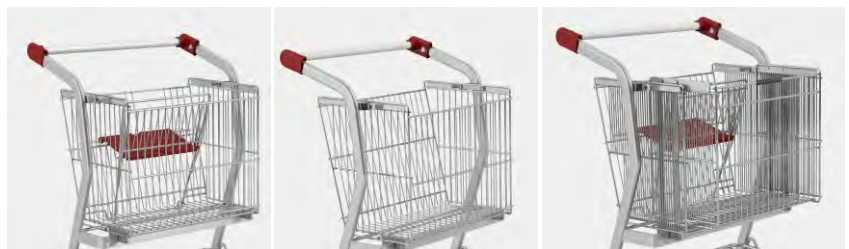

*wire platform*

*full platforma*



In the standard version shopping trolley has standard wheels. Optional accessories (inter alia wheels with brake, coin lock, logo and other accessories) require separate arrangements.

TYPE	Vario 115 with additional set
BASKET CAPACITY	50 l
LOADING OF BASKET	50 kg
LOADING OF ADDITIONAL SIDE SET	50 kg
TOTAL LOADING	250 kg
WHEEL DIAMETER	125 mm
NESTING DISTANCE	360 mm

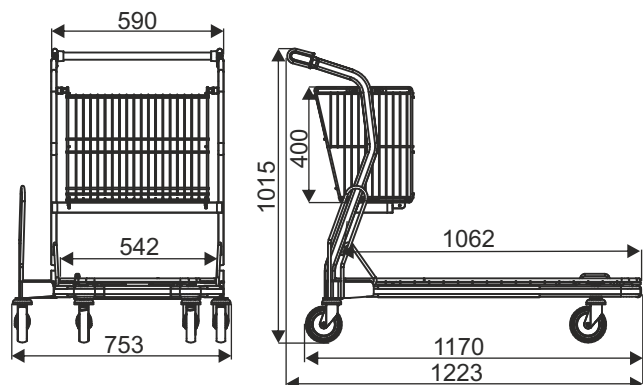

PRODUCT NAME	FINISH	INDEX
Transport trolley Vario 115 with additional set	zinc plated + lacquer	—

### W3 TRANSPORT TROLLEYS

## TRANSPORT TROLLEY VARIO 120



TYPE	Vario 120
BASKET CAPACITY	40 l
LOADING OF BASKET	40 kg
TOTAL LOADING	400 kg
WHEEL DIAMETER	160 mm
NESTING DISTANCE	320 mm

### Trolley is available in the option:

- with the wire platform,
- with full platform ( platform of plywood, anti-slip, waterproof, double-sided foiled).

### Standard finish:

zinc plated, sides are additionally powder coated, what enriches the aesthetics of the trolley and composes with color scheme of the shop.



In the standard version shopping trolley has standard wheels. Optional accessories (inter alia wheels with brake, coin lock, logo and other accessories) require separate arrangements.

Clipboard A4 for Vario 120 (option)

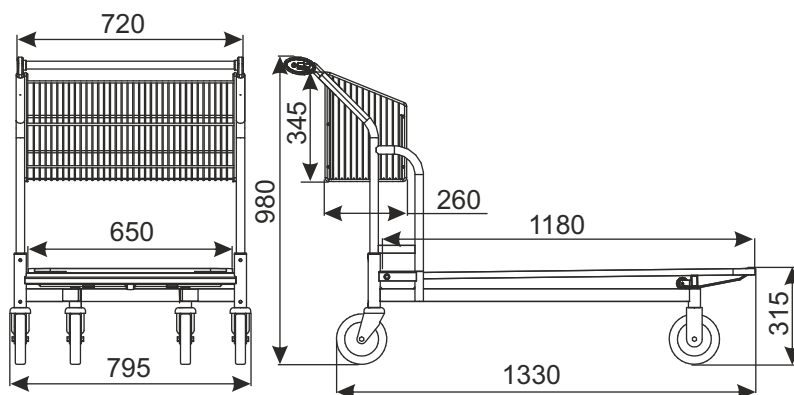

PRODUCT NAME	FINISH	INDEX
Transport trolley Vario 120	zinc plated/powder coated	919-350-738
Clipboard A4 for Vario 120 (option)	stainless steel	919-380-698

## W3 TRANSPORT TROLLEYS

## TRANSPORT TROLLEY VARIO 120S (with folded basket)



TYPE	Vario 120S
BASKET CAPACITY	40 l (folded basket) 70 l (unfolded basket)
LOADING OF BASKET	40 kg
TOTAL LOADING	400 kg
WHEEL DIAMETER	160 mm
NESTING DISTANCE	320 mm

### Trolley is available in the option:

- with the wire platform,
- with full platform ( platform of plywood, anti-slip, waterproof, double-sided foiled).



### Standard finish:

zinc plated, sides are additionally powder coated, what enriches the aesthetics of the trolley and composes with color scheme of the shop.

In the standard version shopping trolley has standard wheels. Optional accessories (inter alia wheels with brake, coin lock, logo and other accessories) require separate arrangements.

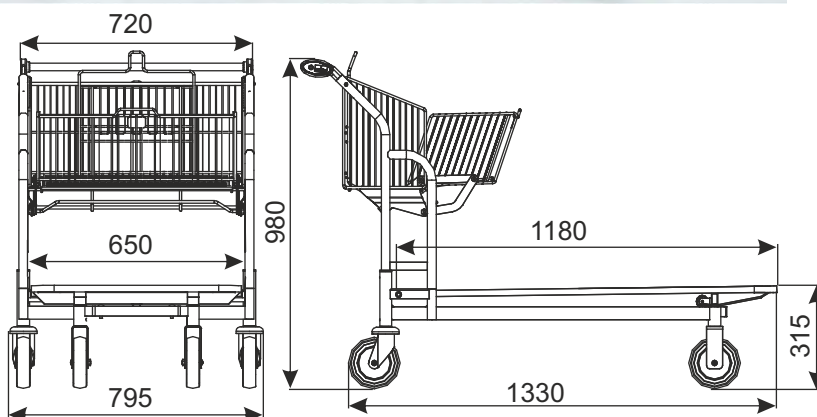

PRODUCT NAME	FINISH	INDEX
Transport trolley Vario 120S	zinc plated/powder coated	919-350-778

### W3 TRANSPORT TROLLEYS

## TRANSPORT TROLLEY VARIO 125

**NEW!**



### Optional equipment

- full platform ( platform of plywood, anti-slip, waterproof, double-sided foiled),
- wire basket,
- fifth wheel.



TYPE	Vario 125
BASKET CAPACITY	27 l
LOADING OF BASKET	30 kg
TOTAL LOADING	350 kg
WHEEL DIAMETER	160 mm
NESTING DISTANCE	370 mm

In the standard version shopping trolley has standard wheels. Optional accessories (inter alia wheels with brake, coin lock, logo and other accessories) require separate arrangements.

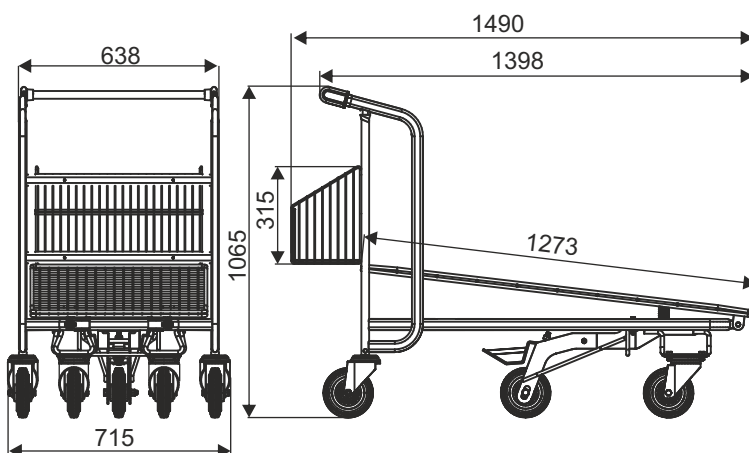

PRODUCT NAME	FINISH	INDEX
Transport trolley Vario 125	zinc plated + lacquer	919-351-450

### W3 TRANSPORT TROLLEYS

## TRANSPORT TROLLEY VARIO 125M

**NEW!**



**Optional equipment:**  
- rear basket



TYPE	Vario 125M
LOADING OF THE UPPER BASKET	50 kg
LOADING OF THE REAR BASKET (option)	30 kg
TOTAL LOADING	450 kg
WHEEL DIAMETER	160 mm
NESTING DISTANCE	350 mm

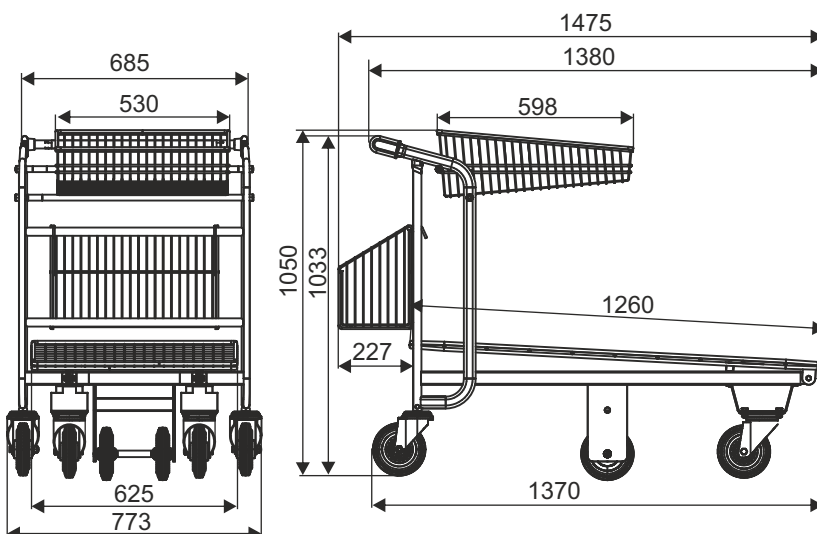

In the standard version shopping trolley has standard wheels. Optional accessories (inter alia wheels with brake, coin lock, logo and other accessories) require separate arrangements.

PRODUCT NAME	FINISH	INDEX
Transport trolley Vario 125M	zinc plated + lacquer	919-351-410

### W3 TRANSPORT TROLLEYS

## TRANSPORT TROLLEY CARRY 80

### Trolley is available in the option:

- with the wire platform,
- with full platform ( platform of plywood, anti-slip, waterproof, double-sided foiled).



TYPE	Carry 80
LOADING	300 kg
WHEEL DIAMETER	125 mm
NESTING DISTANCE	285 mm

Standard finish:  
zinc plated + lacquer

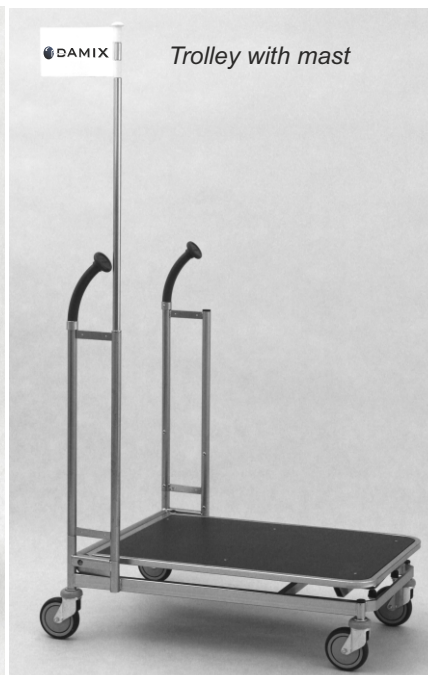
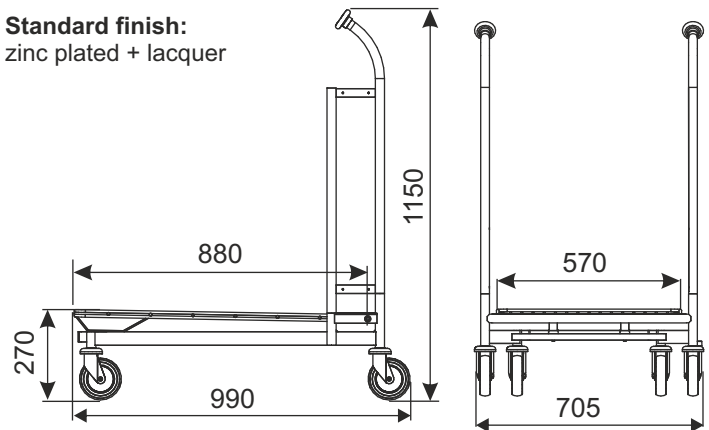

### ADDITIONAL EQUIPMENT:

In the standard version shopping trolley has standard wheels. Optional accessories (inter alia wheels with brake, coin lock, logo and other accessories) require separate arrangements.

PRODUCT NAME	FINISH	INDEX
Transport trolley Carry 80	zinc plated +lacquer	919-350-798

## W3 TRANSPORT TROLLEYS

## TRANSPORT TROLLEY CARRY 90



As a standard is the trolley with one front bar ( mounted to the lifted hatch) or optional without bars.

TYPE	Carry 90
LOADING	300 kg
WHEEL DIAMETER	125 mm
NESTING DISTANCE	250 mm

### Standard finish:

zinc plated, sides are additionally powder coated, what enriches the aesthetics of the trolley and composes with color scheme of the shop.

### ADDITIONAL EQUIPMENT:

In the standard version shopping trolley has standard wheels. Optional accessories (inter alia wheels with brake, coin lock, logo and other accessories) require separate arrangements.

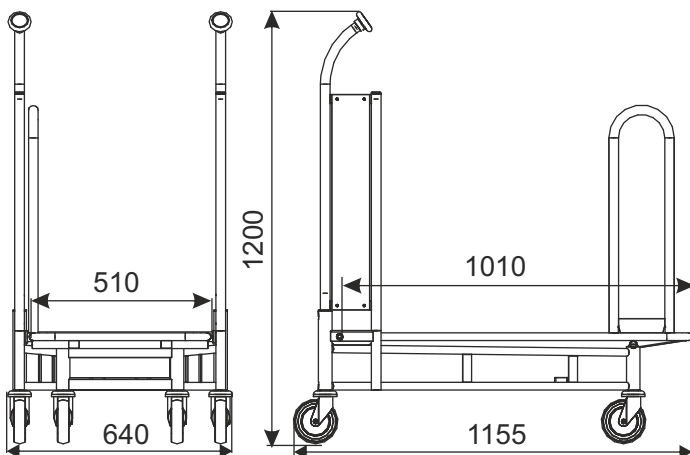

PRODUCT NAME	FINISH	INDEX
Transport trolley Carry 90	zinc plated/powder coated	919-342-998

## W3 TRANSPORT TROLLEYS



## TRANSPORT TROLLEY CARRY 90 FOR TRAVELATOR



As a standard is the trolley with one front bar (mounted to the lifted hatch), with bumper at front and castors for travelator.

TYPE	Carry 90 for travelator
LOADING	130 kg
WHEEL DIAMETER	125 mm
NESTING DISTANCE	250 mm

### Standard finish:

zinc plated, sides are additionally powder coated, what enriches the aesthetics of the trolley and composes with color scheme of the shop.

### ADDITIONAL EQUIPMENT:

- mast,
- lateral logo made of plexi with the graphics,
- coin lock.

Optional accessories require separate arrangements.

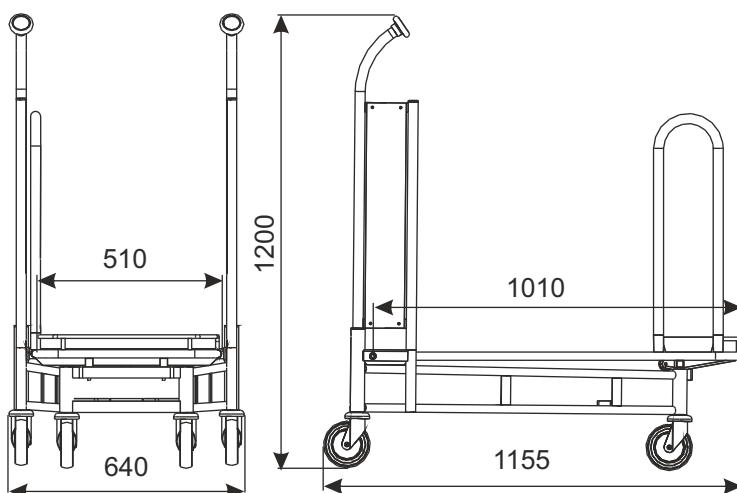

PRODUCT NAME	FINISH	INDEX
Transport trolley Carry 90 for travelator	zinc plated/powder coated	919-343-023

### W3 TRANSPORT TROLLEYS

## TRANSPORT TROLLEY CARRY 95



TYPE	Carry 95
LOADING	300 kg
WHEEL DIAMETER	125 mm
NESTING DISTANCE	310 mm

### Standard finish:

zinc plated, optionally legs are additionally powder coated.

Trolley with full platforms is available in the option with one bar or without bars.

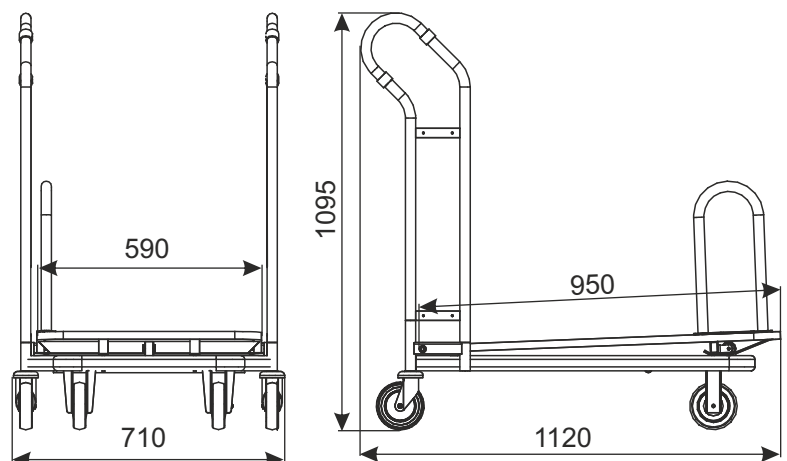

### ADDITIONAL EQUIPMENT:

In the standard version shopping trolley has standard wheels. Optional accessories (inter alia wheels with brake, coin lock, logo and other accessories) require separate arrangements.

PRODUCT NAME	FINISH	INDEX
Transport trolley Carry 95	zinc plated + lacquer	919-351-217

### W3 TRANSPORT TROLLEYS

## TRANSPORT TROLLEY CARRY 100



full platform

Trolley with full platforms is available in the option with one or two front bar ( mounted to the lifted hatch) or without bars. Wire platform without bars.

TYPE	Carry 100
LOADING	300 kg
WHEEL DIAMETER	125 mm
NESTING DISTANCE	275 mm

### Trolley is available in the option:

- with the wire platform,
- with full platform ( platform of plywood, anti-slip, waterproof, double-sided foiled).

### Standard finish:

zinc plated, sides are additionally powder coated, what enriches the aesthetics of the trolley and composes with color scheme of the shop.

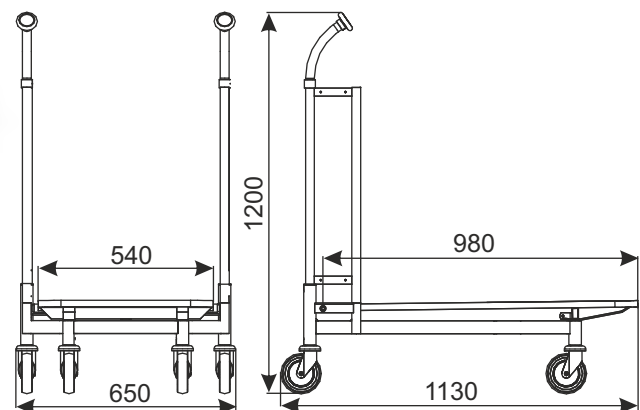

wire platform

### ADDITIONAL EQUIPMENT:

In the standard version shopping trolley has standard wheels. Optional accessories (inter alia wheels with brake, coin lock, logo and other accessories) require separate arrangements.



Bar

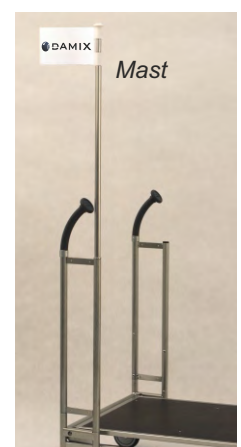

Mast

PRODUCT NAME	FINISH	INDEX
Transport trolley Carry 100	zinc plated/powder coated	919-343-024

## W3 TRANSPORT TROLLEYS

## TRANSPORT TROLLEY CARRY 100 FOR TRAVELATOR



TYPE	Carry 100 for travelator
LOADING	130 kg
WHEEL DIAMETER	125 mm
NESTING DISTANCE	275 mm

The trolley has full platform ( platform of plywood, anti-slip, waterproof, double-sided foiled), wheels for travelator and front stop barrier.

**Standard finish:**

zinc plated, sides are additionally powder coated, what enriches the aesthetics of the trolley and composes with color scheme of the shop.

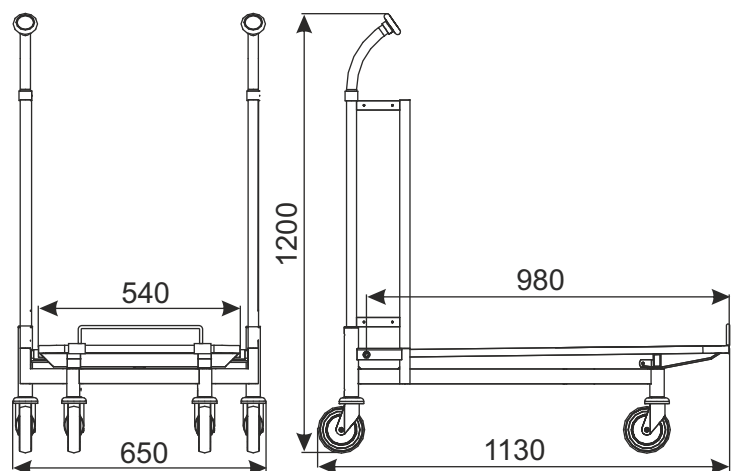

PRODUCT NAME	FINISH	INDEX
Transport trolley Carry 100 for travelator	zinc plated/powder coated	919-343-024

### W3 TRANSPORT TROLLEYS

## TRANSPORT TROLLEY CARRY 100ZR (with closed handle)



Trolley is available in the option with one or two front bar ( mounted to the lifted hatch) or without bars.

TYPE	Carry 100ZR
LOADING	300 kg
WHEEL DIAMETER	125 mm
NESTING DISTANCE	275 mm

### Standard finish:

zinc plated, sides are additionally powder coated, what enriches the aesthetics of the trolley and composes with color scheme of the shop.

### ADDITIONAL EQUIPMENT:

In the standard version shopping trolley has standard wheels. Optional accessories (inter alia wheels with brake, coin lock, logo and other accessories) require separate arrangements.

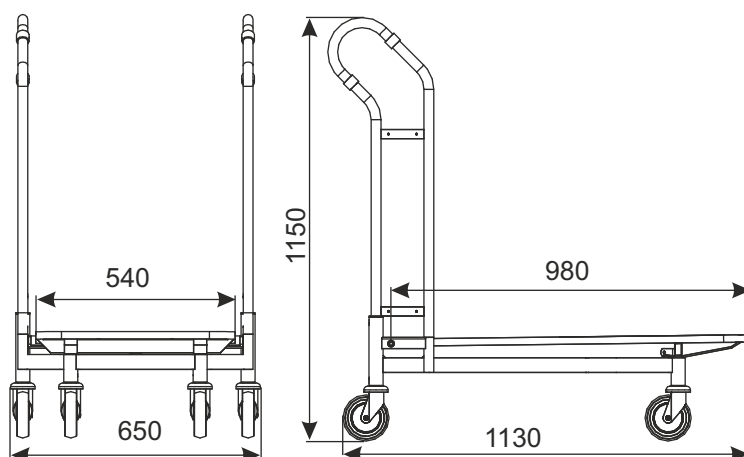

PRODUCT NAME	FINISH	INDEX
Transport trolley Carry 100ZR	zinc plated/powder coated	919-343-808

## W3 TRANSPORT TROLLEYS

## TRANSPORT TROLLEY CARRY 120



### Trolley is available in the option:

- with the wire platform,
- with full platform ( platform of plywood, anti-slip, waterproof, double-sided foiled).

TYPE	Carry 120
LOADING	400 kg
WHEEL DIAMETER	160 mm
NESTING DISTANCE	320 mm

As a standard is the trolley with the wooden platform have two front bars ( mounted to the lifted hatch), optional is available with one bar or without bars. Wire platform without bars.

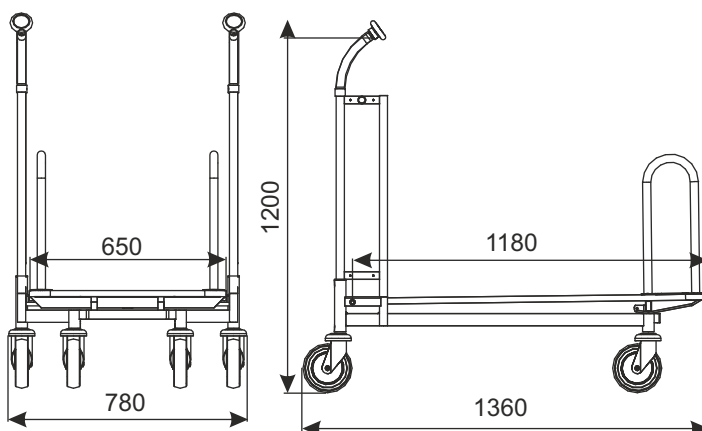

### Standard finish:

zinc plated, sides are additionally powder coated, what enriches the aesthetics of the trolley and composes with color scheme of the shop.

### ADDITIONAL EQUIPMENT:

In the standard version shopping trolley has standard wheels. Optional accessories (inter alia wheels with brake, coin lock, logo and other accessories) require separate arrangements.

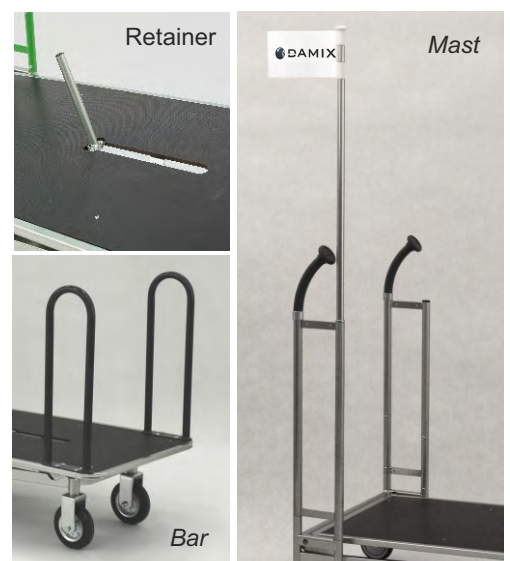

PRODUCT NAME	FINISH	INDEX
Transport trolley Carry 120	zinc plated/powder coated	919-343-793

## W3 TRANSPORT TROLLEYS

## TRANSPORT TROLLEY CARRY 120M



TYPE	Carry 120M
BASKET CAPACITY	50 l
LOADING	500 kg
WHEEL DIAMETER	160 mm
FINISH	zinc plated + thermal setting lacquer
NESTING DISTANCE	340 mm

**Additional equipment:**  
Clipboard A4.

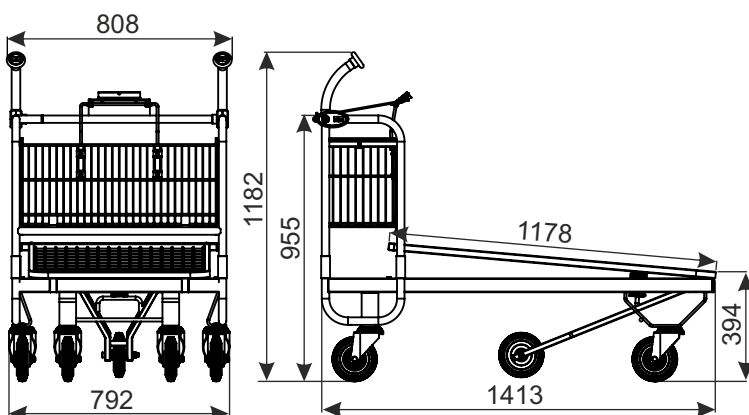

PRODUCT NAME	FINISH	INDEX
Transport trolley Carry 120M	zinc plated + lacquer	919-351-204

### W3 TRANSPORT TROLLEYS

## TRANSPORT TROLLEY CARRY 160



As a standard is the trolley with two front bars ( mounted to the lifted hatch), optional is available with one bar or without bars.

TYPE	Carry 160
LOADING	500 kg
WHEEL DIAMETER	200 mm
NESTING DISTANCE	445 mm

### Standard finish:

zinc plated, sides are additionally powder coated, what enriches the aesthetics of the trolley and composes with color scheme of the shop.

### ADDITIONAL EQUIPMENT:

In the standard version shopping trolley has standard wheels. Optional accessories (inter alia wheels with brake, coin lock, logo and other accessories) require separate arrangements.

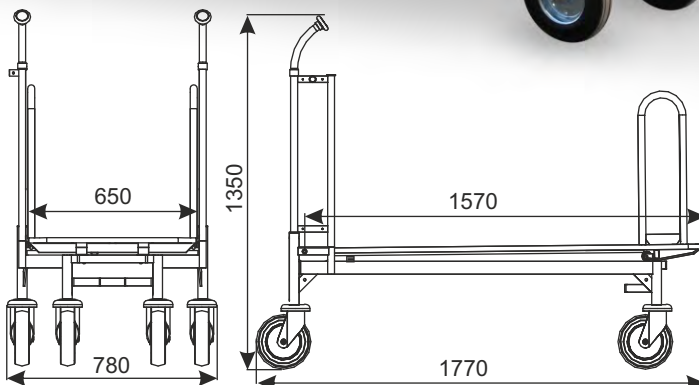

Retainer



Bar



Trolley with mast



### PRODUCT NAME

Transport trolley Carry 160

### FINISH

zinc plated/powder coated

### INDEX

919-343-791

## W3 TRANSPORT TROLLEYS



## TRANSPORT TROLLEY CARRY 160 with the fifth wheel



As a standard is the trolley with two front bars (mounted to the lifted hatch), optional is available with one bar or without bars.

TYPE	Carry 160
LOADING	500 kg
WHEEL DIAMETER	200 mm
NESTING DISTANCE	445 mm

### Standard finish:

zinc plated, sides are additionally powder coated, what enriches the aesthetics of the trolley and composes with color scheme of the shop.

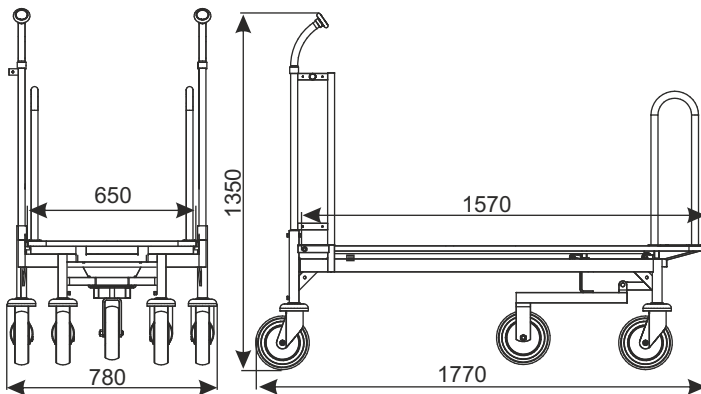

The fifth wheel makes it easy to make turns with the stocked trolley.

### ADDITIONAL EQUIPMENT:

In the standard version shopping trolley has standard wheels. Optional accessories (inter alia wheels with brake, coin lock, logo and other accessories) require separate arrangements.

Retainer

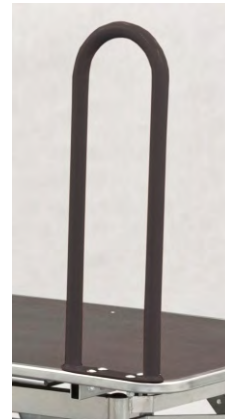

Trolley with mast



Bar



PRODUCT NAME	FINISH	INDEX
Transport trolley Carry 160 with the fifth wheel	zinc plated/powder coated	919-343-791

## W3 TRANSPORT TROLLEYS

## PANEL TRANSPORTER CARRY WP1A



The trolley with a high barrier H- 853



TYPE	Carry WP1A
LOADING	300 kg
WHEEL DIAMETER	160 mm

Trolley for transport of drywall, furniture boards, plywoods, doors, etc. with a height not exceeding 1500 mm.

the trolley is optionally available :  
- with a high barrier H- 853

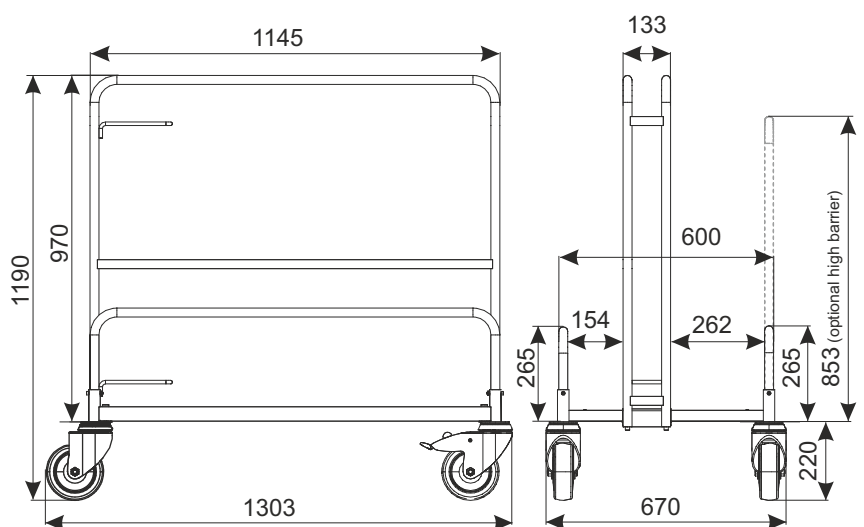

PRODUCT NAME	FINISH	INDEX
Panel transporter Carry WP1A	zinc plated + powder coated	919-344-017

### W3 TRANSPORT TROLLEYS

## PANEL TRANSPORTER CARRY WP1B

**NEW!**



TYPE	Carry WP1B
LOADING	300 kg
WHEEL DIAMETER	160 mm

Trolley for transport of drywall, furniture boards, plywoods, doors, etc. with a height not exceeding 1800 mm.

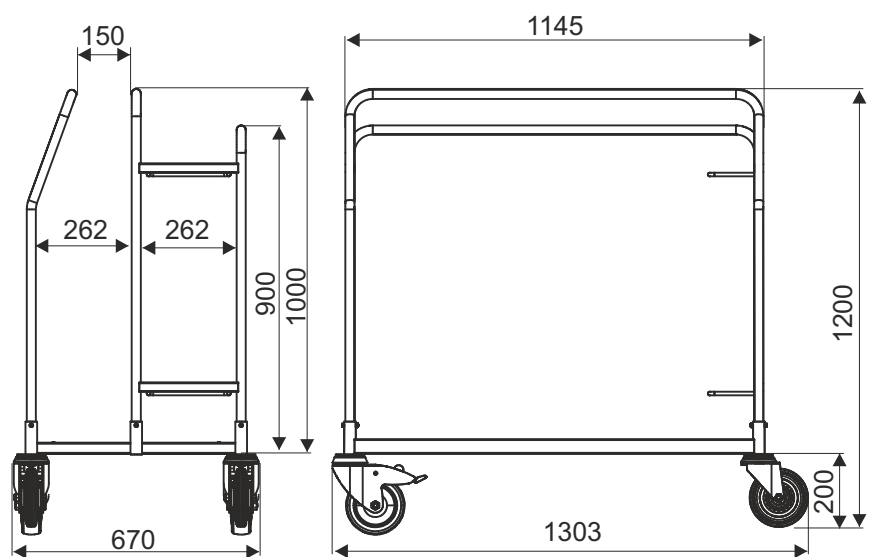

PRODUCT NAME	FINISH	INDEX
Panel transporter Carry WP1B	zinc plated + powder coated	919-344-190

### **W3** TRANSPORT TROLLEYS

## PANEL TRANSPORTER CARRY WP3



TYPE	Carry WP3
TOTAL LOADING	300 kg
LOADING OF BASKET	30kg
WHEEL DIAMETER	160 mm

*Optional equipment:  
basket to the transport trolley WP3*

Trolley for transport of drywall, furniture boards, plywoods, doors, etc. with a height not exceeding 2000 mm.

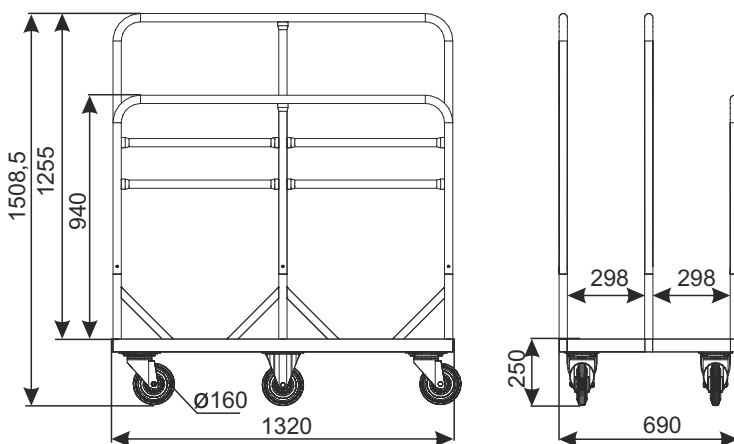

PRODUCT NAME	FINISH	INDEX
Panel transporter Carry WP3	zinc plated/powder coated	919-344-048
Basket to the panel transporter Carry WP3 (optional equipment)	zinc plated+lacquer	919-351-258

### W3 TRANSPORT TROLLEYS

## PANEL TRANSPORTER CARRY WP3B



TYPE	Carry WP3B
TOTAL LOADING	300 kg
LOADING OF BASKET	50 kg
WHEEL DIAMETER	160 mm

Trolley for transport of drywall, furniture boards, plywoods, doors, etc. with a height not exceeding 2000 mm, optionally with wire basket.

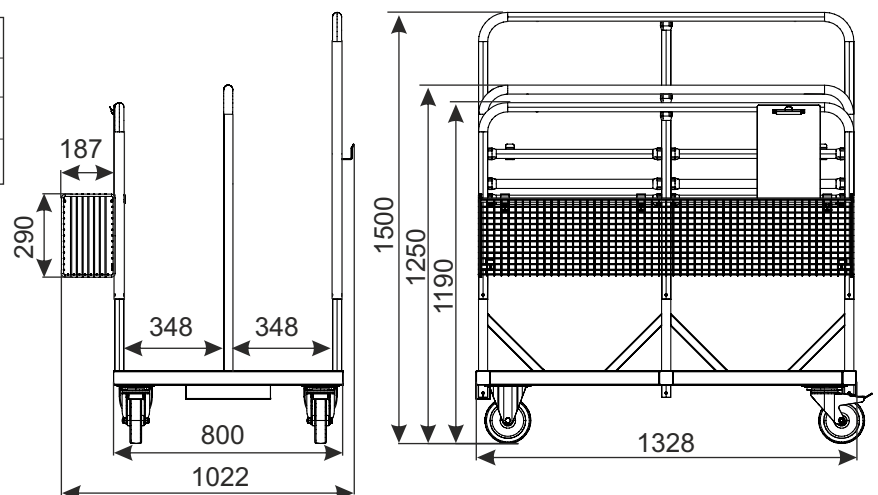

PRODUCT NAME	FINISH	INDEX
Panel transporter Carry WP3B	zinc plated + powder coated	919-351-372
Basket to the panel transporter Carry WP3B (option)	zinc plated + lacquer	919-351-363

### W3 TRANSPORT TROLLEYS

## PANEL TRANSPORTER CARRY WP6B

**NEW!**



TYPE	Carry WP6B
TOTAL LOADING	350 kg
LOADING OF BASKET	50 kg
WHEEL DIAMETER	160 mm

Trolley for transport of drywall, furniture boards, plywoods, doors, etc. with a height not exceeding 2100mm.

Mounting the railings to the base

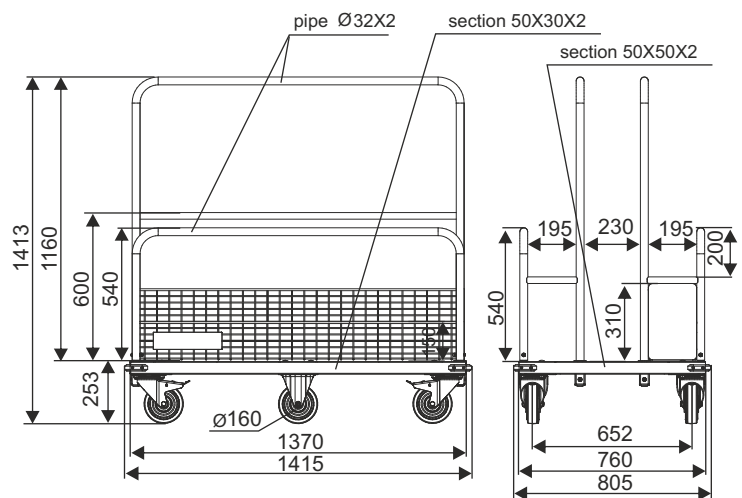
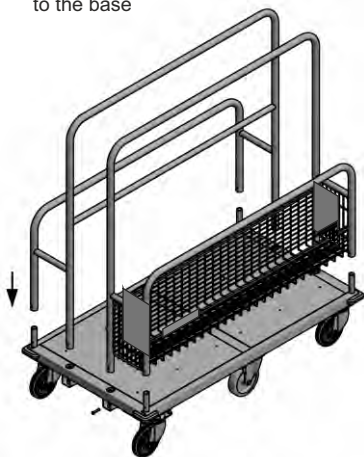

PRODUCT NAME	FINISH	INDEX
Panel transporter Carry WP6B	zinc plated + powder coated	919-351-608

### W3 TRANSPORT TROLLEYS

## PANEL TRANSPORTER CARRY WP4



TYPE	Carry WP4
TOTAL LOADING	300 kg
LOADING OF SHELF	50 kg
LOADING OF BASKET	50 kg
WHEEL DIAMETER	200 mm
NESTING DISTANCE	280 mm

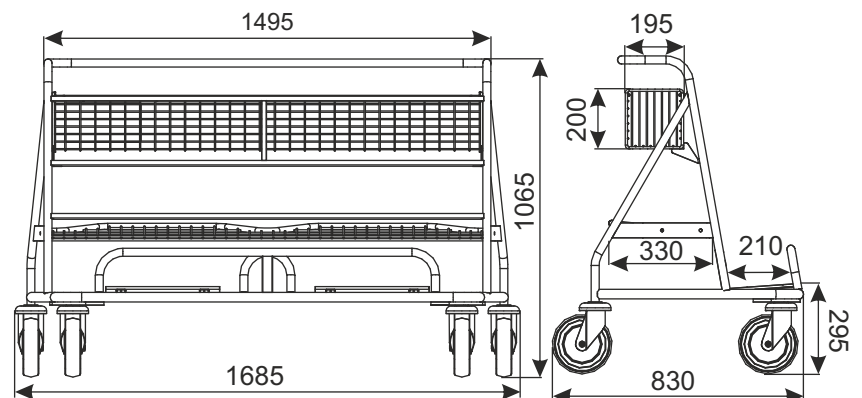

Trolley for transport of drywall, furniture boards, plywoods, doors, etc. with a height not exceeding 1250 mm.

In the standard version, the trolley has 4 swivel wheels, including 1 with a brake.

### ADDITIONAL EQUIPMENT:

- basket,
- shelf,
- board with logo.

Additionally the trolley is equipped with a wire basket to transport small parts.

PRODUCT NAME	FINISH	INDEX
Panel transporter Carry WP4	zinc plated+lacquer/powder coated	919-343-904
ADDITIONAL EQUIPMENT	FINISH	INDEX
Basket to the panel transporter Carry WP4	zinc plated+lacquer	919-350-892
Shelf to the panel transporter Carry WP4	zinc plated+lacquer	919-350-891
Board with logo	zinc plated+lacquer/powder coated	—

## W3 TRANSPORT TROLLEYS

## PANEL TRANSPORTER CARRY WP4A



TYPE	Carry WP4A
TOTAL LOADING	300 kg
LOADING OF BASKET	50 kg
WHEEL DIAMETER	200 mm
NESTING DISTANCE	430 mm

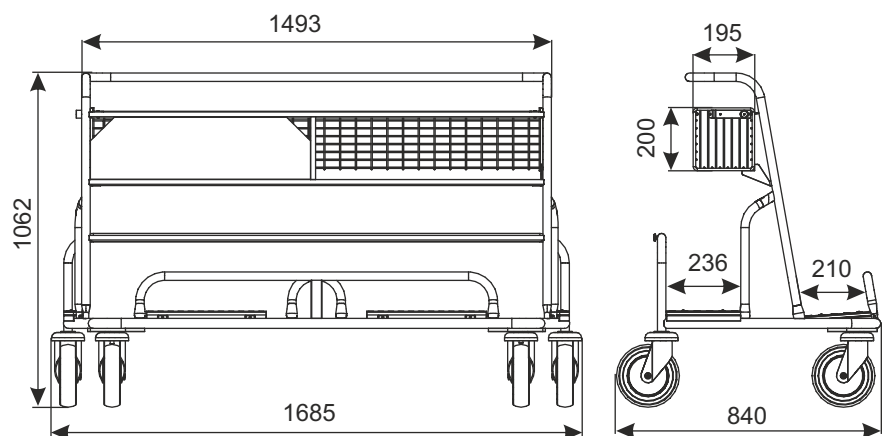

Trolley for transport of drywall, furniture boards, plywoods, doors, etc. with a height not exceeding 1250 mm.

Additionally the trolley is equipped with a wire basket to transport small parts.

PRODUCT NAME	FINISH	INDEX
Panel transporter Carry WP4A	zinc plated+powder coated	919-344-015

### W3 TRANSPORT TROLLEYS



## PANEL TRANSPORTER CARRY WP4BW

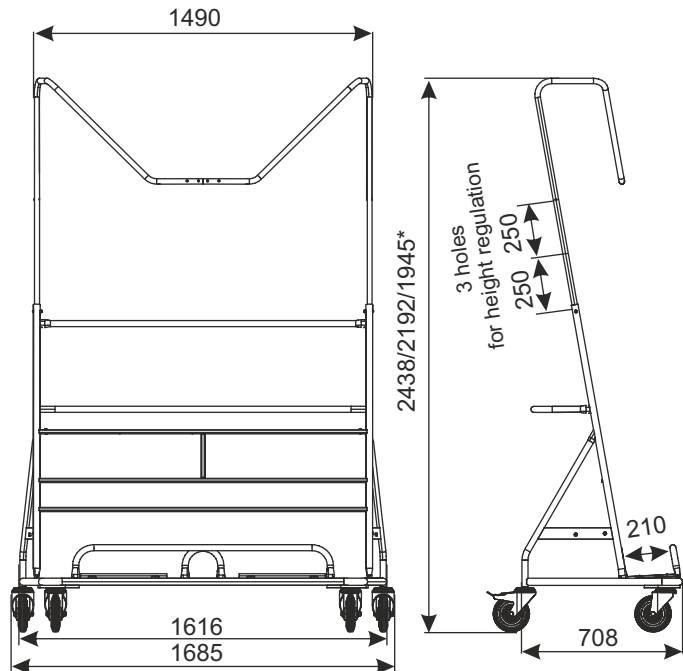

\* 2438 mm - the first level of regulation (the handle of trolley is mounted on bottom hole)  
 2192 mm - the second level of regulation (the handle of trolley is mounted on middle hole)  
 1945 mm - the third level of regulation (the handle of trolley is mounted on upper hole)

TYPE	Carry WP4BW
LOADING	200 kg
WHEEL DIAMETER	160 mm
NESTING DISTANCE	280 mm

The trolley is intended to carry cardboard and gypseous plates as well furniture plates, plywoods and door till the height 2100 mm. Optionally the trolley can be equipped with shelf and wire basket for small items.



trolley with a plate



trolley with additional equipment (wire shelf and basket)

Maximum and minimum height of plate for a particular level of regulation:

The way of the plate putting:

The maximum width of plate:

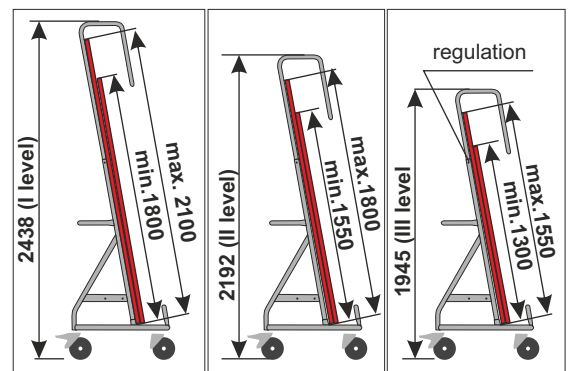
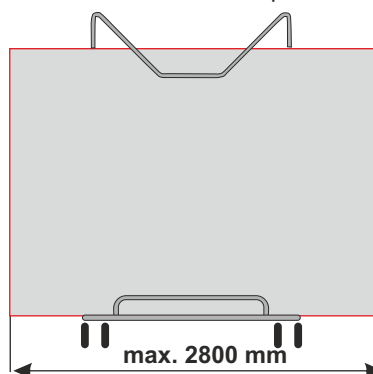
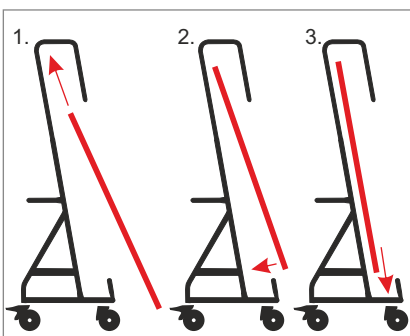

PRODUCT NAME	FINISH	INDEX
Panel transporter Carry WP4BW	zinc plated+lacquer	919-344-077

### W3 TRANSPORT TROLLEYS

## PANEL TRANSPORTER CARRY WP5



It's convenient trolley dedicated for transporting different panels, for example furniture panels, cardboard panels, gypseous panels, plywoods, door, boards. Solid construction of trolleys allows the capacity up to 300 kg. The trolley can be equipped with an antitheft mast with flag.



trolley with optional equipment

Wheels Ø 160 mm - 2 back wheels with brakes ensure the safety of goods on trolley. Coin lock system and the mast anti-theft with customisable flag allow you to be vigilant against theft.

### Capacity:

Trolley's dimensions allow to locate large products.

### Coating:

Zinc + powder coating

### Options:

- one or two baskets,
- metal sheet
- mast with possibility of personalized flag.

TYPE	CARRY WP5
TOTAL LOADING	300 kg
WHEEL DIAMETER	160 mm
NESTING DISTANCE	300 mm

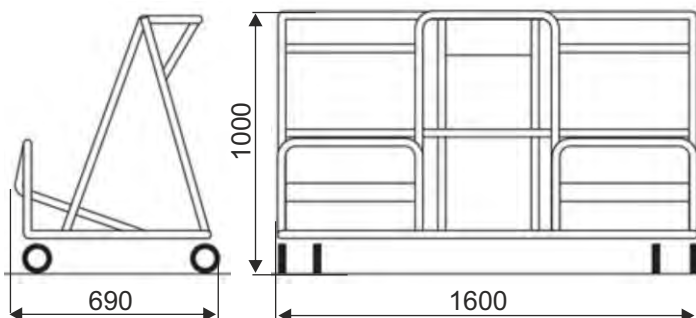

PRODUCT NAME	FINISH	INDEX
Panel transporter Carry WP5	zinc + powder coating	919-351-368

## W3 TRANSPORT TROLLEYS

## SINGLE-AXLE CARRIAGE FOR PANELS

**NEW!**



**Finish:**  
Zinc plated  
+ powder coating  
Wheel diameter: **200 mm**

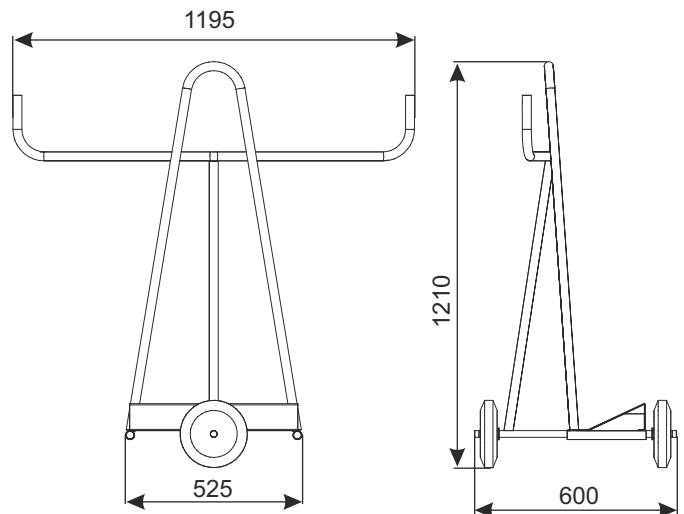

PRODUCT NAME	FINISH	INDEX
Single-axle carriage for panels	Zinc plated + powder coating	919-351-429

### **W3** TRANSPORT TROLLEYS

## TROLLEY FOR FENCE PANELS



**Standard finish:** zinc plated + lacquer, frame: hot-dip zinc.

**Technical data:** Construction made of sections, 4 wheels with a diameter of 125 mm (2 pcs. Fixed castors, 2 pcs. Swivel wheels with brake).

**Maximum loading:** 100 kg

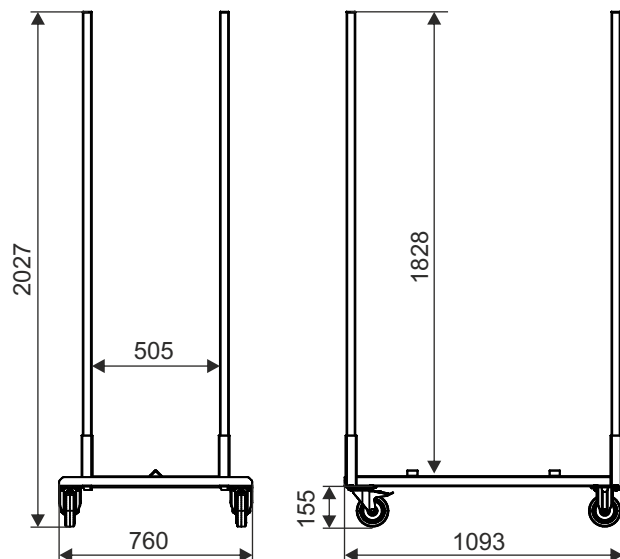

PRODUCT NAME	FINISH	INDEX
Trolley for fence panels	zinc	922-350-016

### E3 SPECIAL RETAIL EQUIPMENT



## CUSTOMER GUIDANCE SYSTEMS

To ensure order in building and customer's guidance system we have prepared in our offer system of entrance gates opened automatically (photoelectric cell and radar) or manually operated as well as equipment supporting checkout barriers, trolley entrances and room partitions. Various range of products let design and use different combinations of entrance and exit systems. Sophisticated design, esthetics of manufacture, ergonomics of constructional solutions are our advantage. All this with connection with the safety will allow for setting in order the sale within one shopping area.

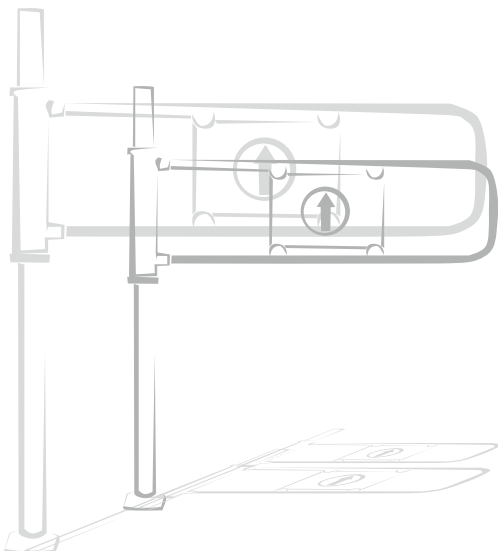

- 1 Electronic entrance gate Porta'e Radar
- 2 Electronic entrance gate Porta'e Infra
- 3 Electronic gate Porta-e Noon with a code scanner
- 4 Mechanical entrance gate Porta'm
- 5 Mechanical entrance pendulous gate Porta'M2
- 6 Checkout barrier Porta'C1
- 7 Checkout barrier Porta'C2
- 8 Mounted checkout barrier with coin lock and high bar
- 9 Checkout barrier without lock
- 10 Checkout barrier with lock
- 11 Checkout barrier without lock with high bar
- 12 Checkout barrier with lock with high bar
- 13 Clamp for fixing the checkout barrier
- 14 Turnstile Porta'turna
- 15 Vertical stand to the turnstile with arms
- 16 Trolley pass L 800
- 17 Stand with pull-out strap L-2000
- 18 Room partition H 1085
- 19 Entry barrier with billboard and fender
- 20 Billboard 700x500 with holders
- 21 Room partition H-2000 (plexi with clamps)
- 22 Room partition H-2000 (grate + plexi)
- 23 Tight partition with the full bottom
- 24 Fender near the floor
- 25 Fender fixed to the stand
- 26 Accessories to fenders

*The reproduce without prior permission is forbidden. In order to improve, the manufacturer reserves the right to implement modifications in its products. Recommendations for installation and use the products are provided for informational purposes only and does not imply any liability on the part of the manufacturer.*

## ELECTRONIC ENTRANCE GATE PORTA'E RADAR



An electronic gate Porta'e RADAR is steering by radar as standard without lighting. Gate can be available in two option: right or left - opens in right side or left side. The gate opens automatically in the direction of entry as you approach it. The gate closes also automatically.

Installed "anty-panic" system prevents from opening a gate in opposite direction. This system allows you to open an emergency gate at the appropriate pressure despite the blockade. Gateway attached to the ground.

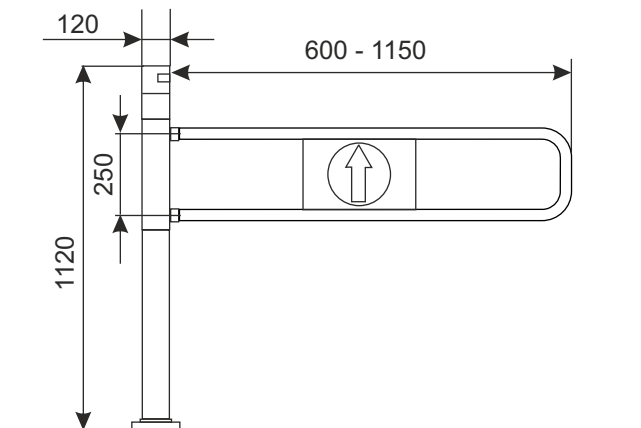

As an option, it is possible to mount an arm to the gate:

- plexiglass (thickness 8 mm),
- with engraved drawing,
- illuminated (the effect of lighting is visible on the engraved drawing and on the edges of the arm).



PRODUCT NAME	FINISH	INDEX
Electronic entrance gate Porta'e Radar	chrome	07A001

### S CUSTOMER GUIDANCE SYSTEMS

## ELECTRONIC ENTRANCE GATE PORTA'E INFRA

An electronic gate Porta'e Infra is steering by photoelectric cell as standard without lighting. Gate can be available in two option: right or left - opens in right side or left side. The gate opens automatically in the direction of entry as you approach it. The gate closes also automatically.

Installed "anty-panic" system prevents from opening a gate in opposite direction. This system allows you to open an emergency gate at the appropriate pressure despite the blockade. Gateway fixed to the ground.

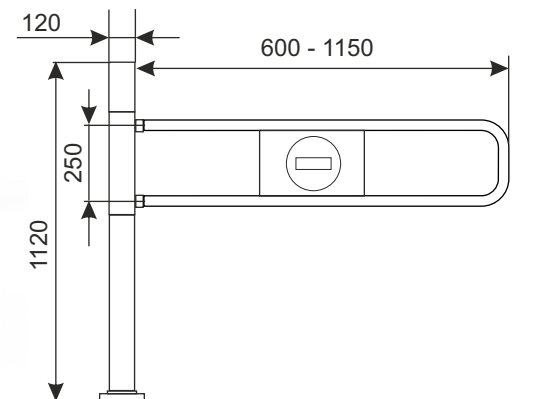

As an option, it is possible to mount an arm to the gate:

- plexiglass (thickness 8 mm),
- with engraved drawing,
- illuminated (the effect of lighting is visible on the engraved drawing and on the edges of the arm).



PRODUCT NAME	FINISH	INDEX
Electronic entrance gate Porta'e Infra	chrome	07A004

### S CUSTOMER GUIDANCE SYSTEMS



## ELECTRONIC GATE PORTA'E NOON WITH A CODE SCANNER (THE SELF-SERVICE CHECKOUT ZONE)

**NEW!**

Basic equipment of the system is electronic gate Porta'e Noon and the stand with a code scanner.

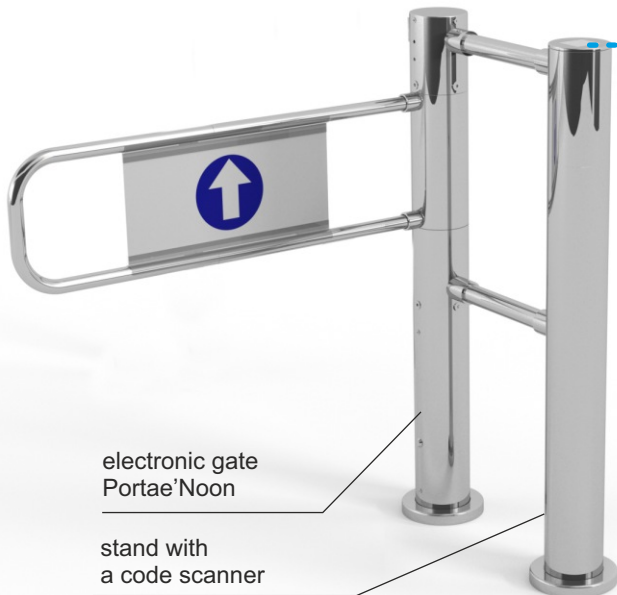

Built-in microcomputer with barcode scanner and QR

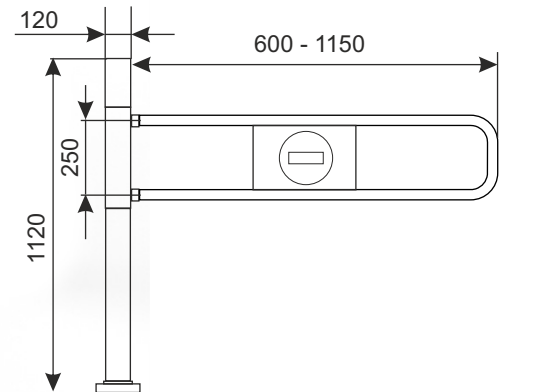

Porta'e Noon electronic gate with a motor and a main board interacting with a stand with a barcode reader in the self-service checkout area.

The gates will open only after the payment process has been completed and the receipt has been scanned through the barcode or QR code reader placed on the stand. The gate closes also automatically.

Standard without lighting.

Gate can be available in two option: right or left - opens in right side or left side.

Installed "anty-panic" system prevents from opening a gate in opposite direction. This system allows you to open an emergency gate at the appropriate pressure despite the blockade. Gateway fixed to the ground.

As an option, it is possible to mount an arm to the gate:

- plexiglass (thickness 8 mm),
- with engraved drawing,
- illuminated (the effect of lighting is visible on the engraved drawing and on the edges of the arm).



PRODUCT NAME	FINISH	INDEX
Electronic gate Porta-e Noon with a code scanner	powder coated	-
Electronic gate Porta-e Noon with a code scanner	chrome	-

### **S** CUSTOMER GUIDANCE SYSTEMS

## ELECTRONIC GATE PORTA'E NOON WITH A CODE SCANNER (THE SELF-SERVICE CHECKOUT ZONE)

**NEW!**

For protection reason of self-service checkout area against thefts, it is required a system able to verify whether the customer has paid for his shopping.

Such solution is provided by our original computer program integrated with the barcode scanner or QR checks the validity of the receipt and after scanning it opens the gate or informs about the non-compliance of the receipt.

### Exit Control System self-service checkout zones:

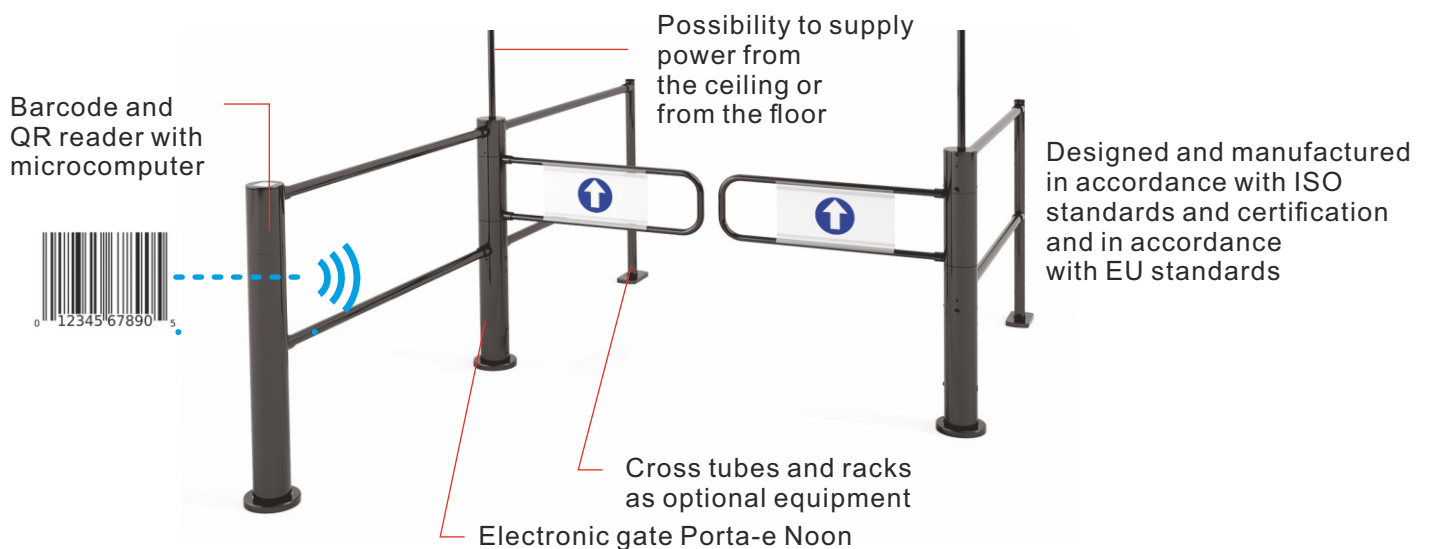

#### ■ Basic equipment:

Electronic gate opening to left or right side with motor and motherboard stand with code scanner

#### ■ Accessories:

Racks, cross tubes and many other elements, thanks to which you can tightly designate zones and target the customer

#### ■ Coating:

powder-coated or chrome

#### ■ Dimensions:

Height of stand and gate: 1120mm  
Diameter of stand and gate post: 120mm  
Width of passage: max. 1150mm for one gate

### Integration of the gate system with a code reader into the self-service checkout zone:



## S CUSTOMER GUIDANCE SYSTEMS

## MECHANICAL ENTRANCE GATE PORTA'M

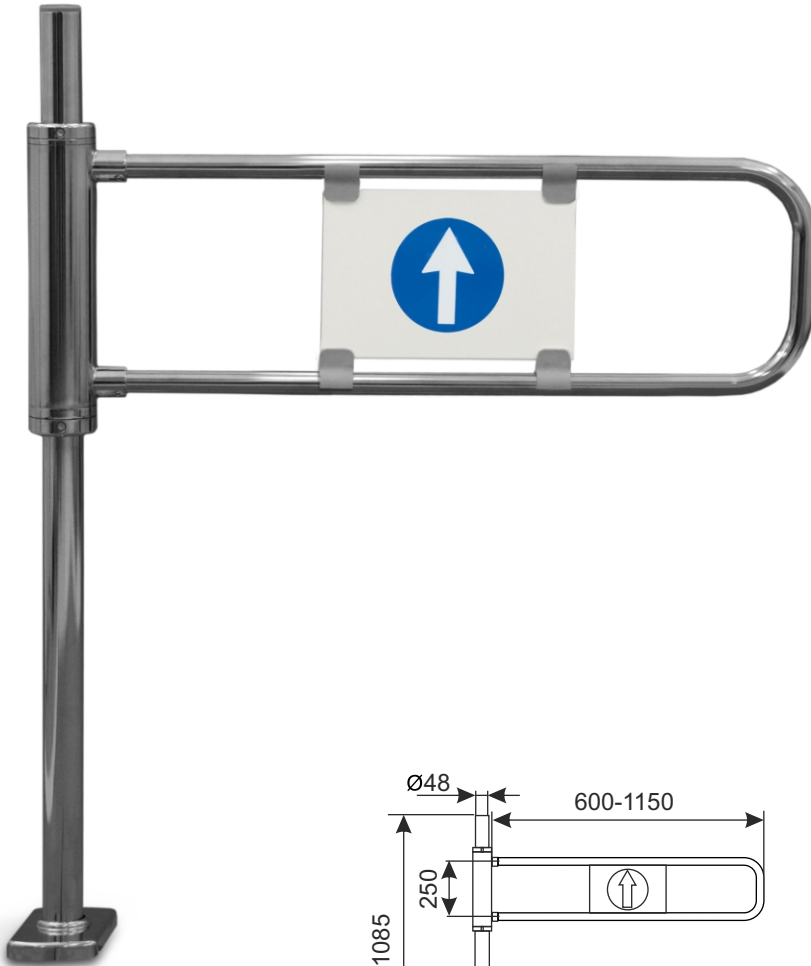

The gate can be available in two options: right or left - opens in right side or left side. It depends on the type of the mounted spring. The gate can be opened by pushing the arm toward the entrance and it closes automatically.

Installed "anti-panic" system prevents from opening a gate in opposite direction. This system allows you to open an emergency gate at the appropriate pressure despite the blockade. Gateway fixed to the ground.

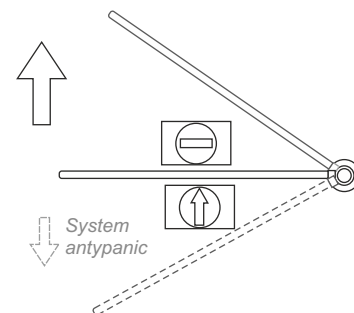
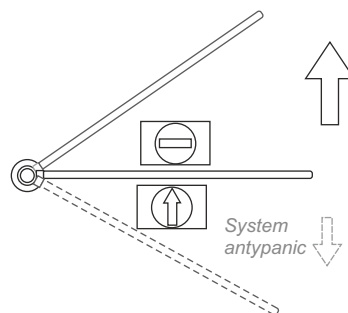
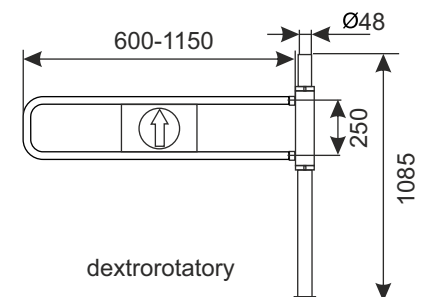
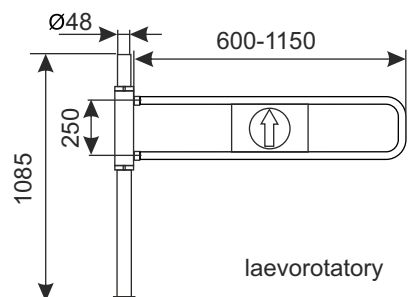

PRODUCT NAME  
Mechanical entrance gate Porta'm

FINISH  
chrome

INDEX  
BRAMKA\_PORTA'M\_L/P\_CHROM

### S CUSTOMER GUIDANCE SYSTEMS

DAMIX Sp z o.o. ul. Bohaterów Czerwca 1956r. nr 3; PL - 87-500 Rypin  
tel. +48 54 280 34 93; fax +48 54 280 45 40; e-mail: damix@damix.pl; handel@damix.pl, www.damix.pl

All rights reserved  
04 04 2024

## MECHANICAL ENTRANCE PENDULOUS GATE PORTA'M2

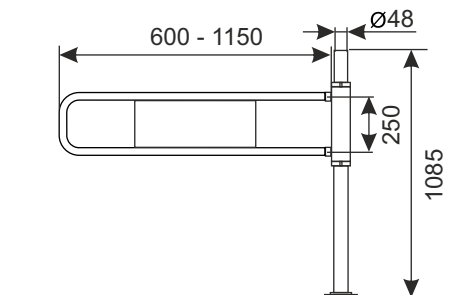
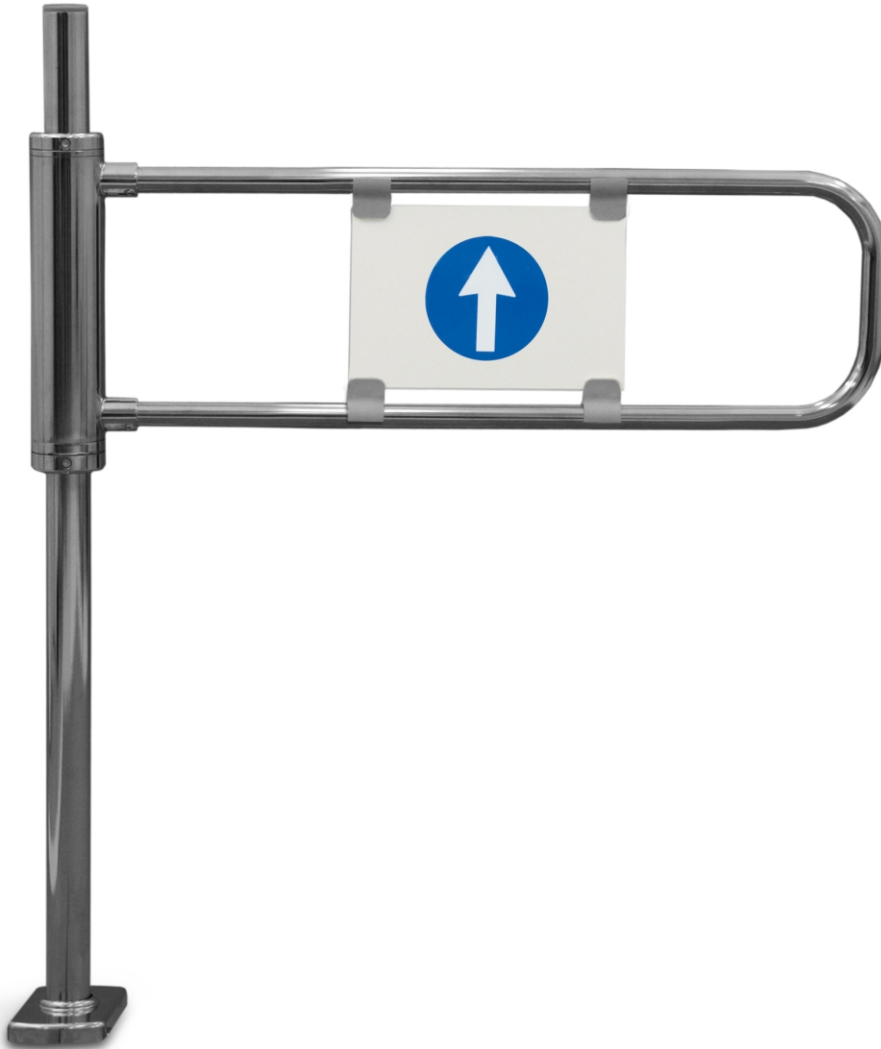

Bidirectional gate - opens in right side and left side. It can be opened by pushing the arm toward the requested direction and it closes automatically. Gateway fixed to the ground.

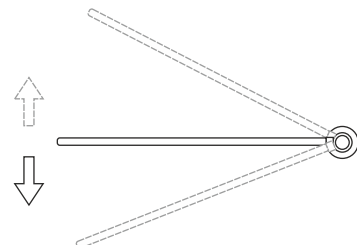

PRODUCT NAME	FINISH	INDEX
Mechanical entrance pendulous gate Porta'm2	chrome	BRAMKA_WACH_PORTA'M2_CHROM

### S CUSTOMER GUIDANCE SYSTEMS

DAMIX Sp z o.o. ul. Bohaterów Czerwca 1956r. nr 3; PL - 87-500 Rypin  
tel. +48 54 280 34 93; fax +48 54 280 45 40; e-mail: damix@damix.pl; handel@damix.pl, www.damix.pl

All rights reserved  
04 04 2024

## CHECKOUT BARRIER PORTA'C1

Checkout barrier Porta'C1 with low bar H-250



The gate is used in checkouts area.

Bidirectional gate - opens in right side and left side. To open or close the gate turn the key in lock, lift the lock and turn the swivel arm in requested direction.

Installed "anti-panic" system prevents from opening a gate in opposite direction. This system allows you to open an emergency gate at the appropriate pressure despite the blockade. Gateway fixed to the ground.

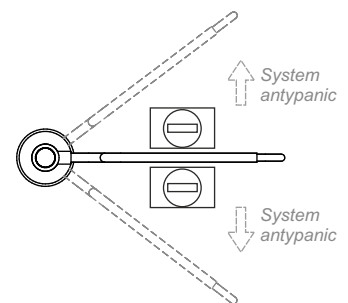
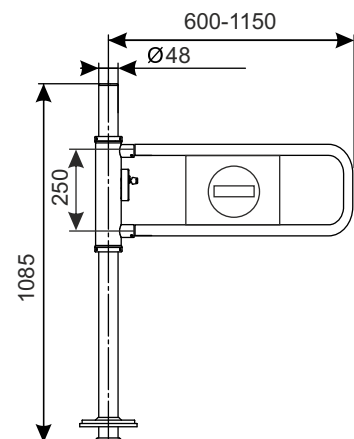

PRODUCT NAME	FINISH	INDEX
Checkout barrier Porta'c1	chrome	BRAMKA_PRZYKAS_PORTA'C1_CHROM

### **S** CUSTOMER GUIDANCE SYSTEMS

## CHECKOUT BARRIER PORTA'C2

Checkout barriers Porta'C2 with high bar H-725

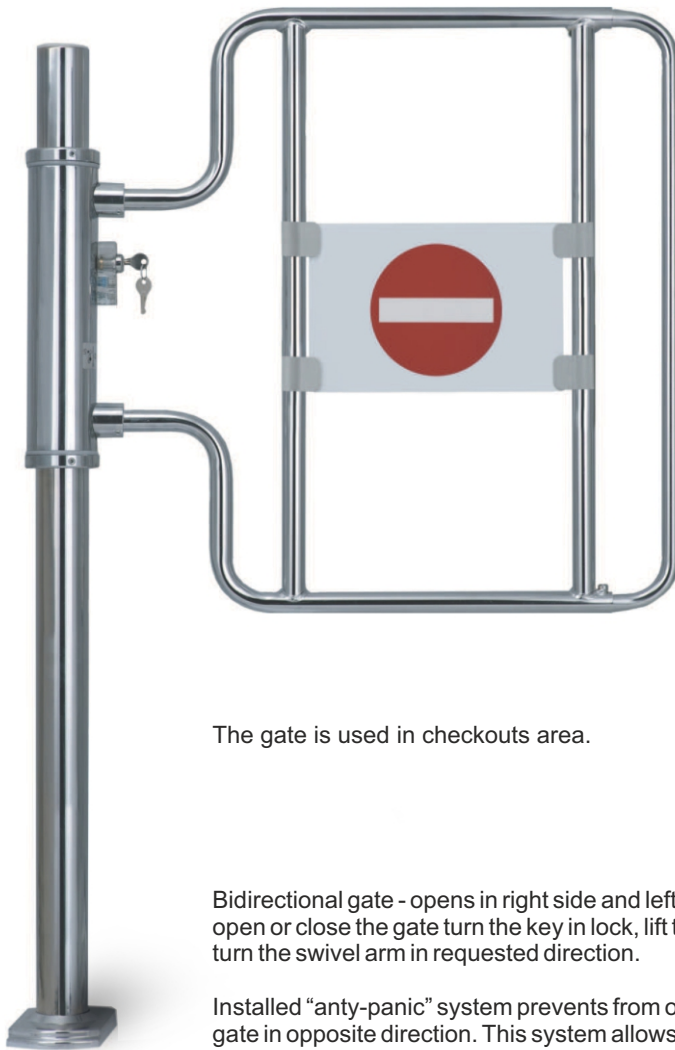

The gate is used in checkouts area.

Bidirectional gate - opens in right side and left side. To open or close the gate turn the key in lock, lift the lock and turn the swivel arm in requested direction.

Installed "anty-panic" system prevents from opening a gate in opposite direction. This system allows you to open an emergency gate at the appropriate pressure despite the blockade.

There is possibility of adjusting arm length to 790 mm to 1100 mm.

Gateway fixed to the ground.

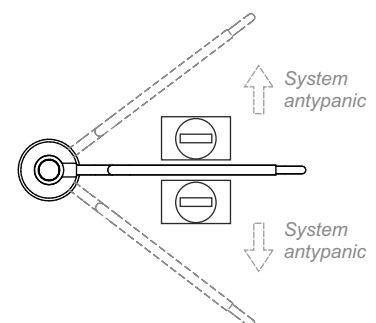
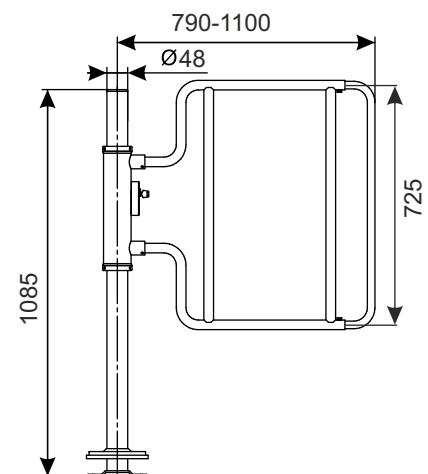

PRODUCT NAME	FINISH	INDEX
Checkout barrier Porta'c2	chrome	BRAMKA_PRZYKAS_PORTA'C2_CHROM

### S CUSTOMER GUIDANCE SYSTEMS

## MOUNTED CHECKOUT BARRIER WITH COIN LOCK AND HIGH BAR

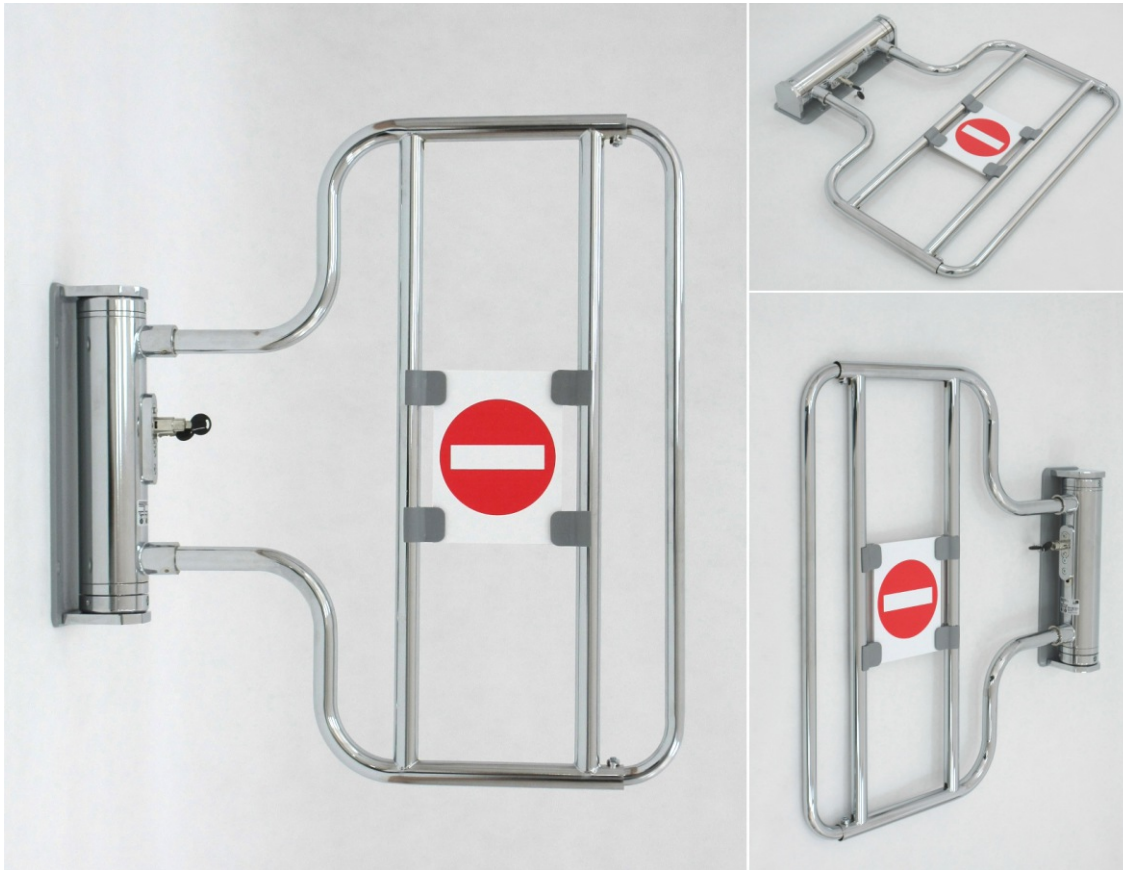

The gate is used in checkout area. Bidirectional gate - opens in right side and left side. To open or close the gate turn the key in lock, lift the lock and turn the swivel arm in requested direction.

Installed "anty-panic" system prevents from opening a gate in opposite direction. This system allows you to open an emergency gate at the appropriate pressure despite the blockade. There is possibility of adjusting arm length to 600mm to 800 mm.

Gateway fixed to the checkout box.

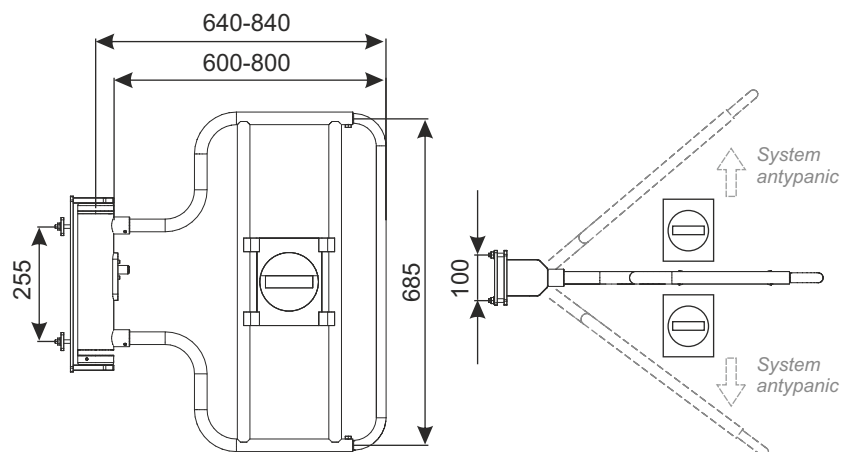

PRODUCT NAME	FINISH	INDEX
Mounted checkout barrier with coin lock and high bar	chrome	BRAMKA_PRZYKAS_BOKS_CHROM

### S CUSTOMER GUIDANCE SYSTEMS

## CHECKOUT BARRIER WITHOUT LOCK

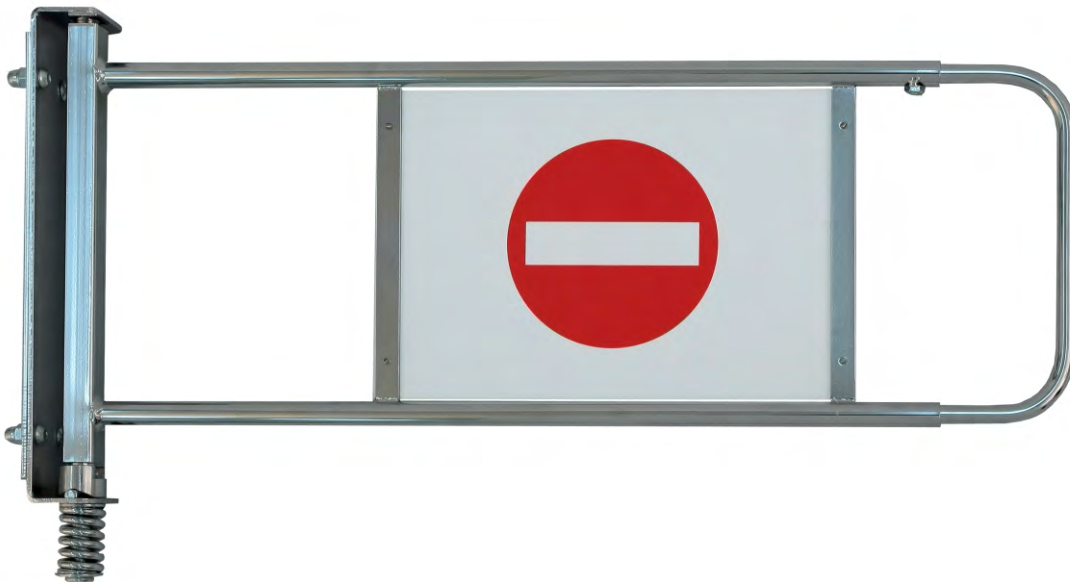

The gate is used in checkouts area.

Bidirectional gate - opens in right side and left side. To open or close the gate lift the swivel arm and turn in requested direction.

Installed "anty-panic" system prevents from opening a gate in opposite direction. This system allows you to open an emergency gate at the appropriate pressure despite the blockade. There is possibility of adjusting arm length to 600 mm to 800 mm.

Gateway fixed to the checkout box.

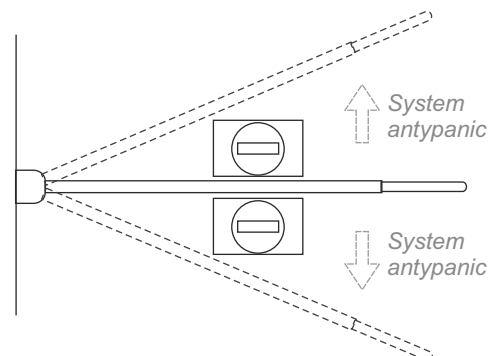
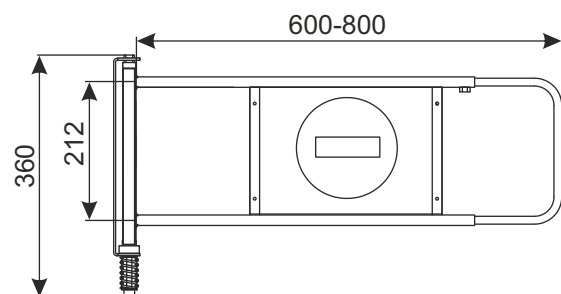

PRODUCT NAME	FINISH	INDEX
Checkout barrier without lock	chrome	919-320-557

### **S** CUSTOMER GUIDANCE SYSTEMS



## CHECKOUT BARRIER WITH LOCK

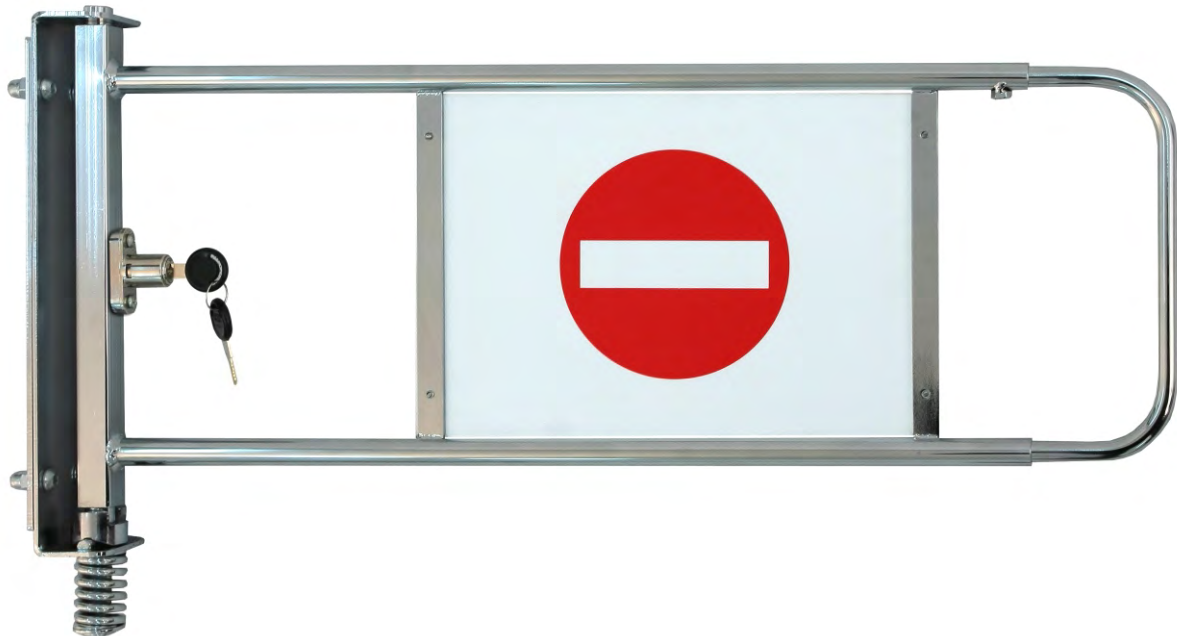

The gate is used in checkouts area.

Bidirectional gate - opens in right side and left side. To open or close the gate turn the key in lock, lift the lock and turn the swivel arm in requested direction.

Installed "anty-panic" system prevents from opening a gate in opposite direction. This system allows you to open an emergency gate at the appropriate pressure despite the blockade.

There is possibility of adjusting arm length to 600 mm to 800 mm.

Gateway fixed to the checkout box.

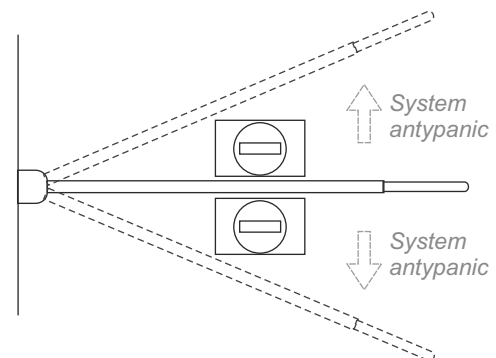
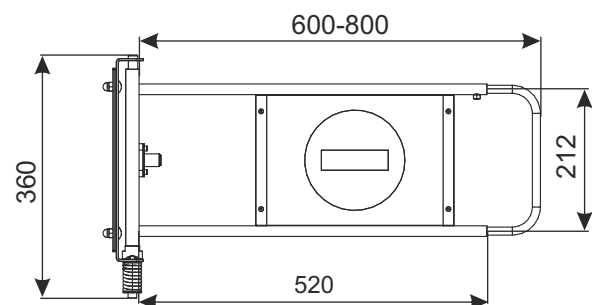

PRODUCT NAME	FINISH	INDEX
Checkout barrier with lock	chrome	919-320-594

### S CUSTOMER GUIDANCE SYSTEMS

## CHECKOUT BARRIER WITHOUT LOCK WITH HIGH BAR



The gate is used in checkouts area.

Bidirectional gate - opens in right side and left side. To open or close the gate lift the swivel arm and turn in requested direction.

Installed "anty-panic" system prevents from opening a gate in opposite direction. This system allows you to open an emergency gate at the appropriate pressure despite the blockade.

There is possibility of adjusting arm length to 600 mm to 800 mm.

Gateway fixed to the checkout box.

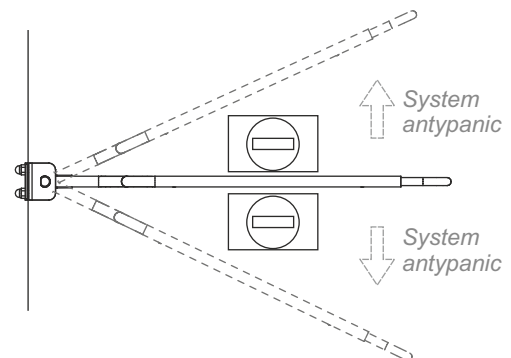
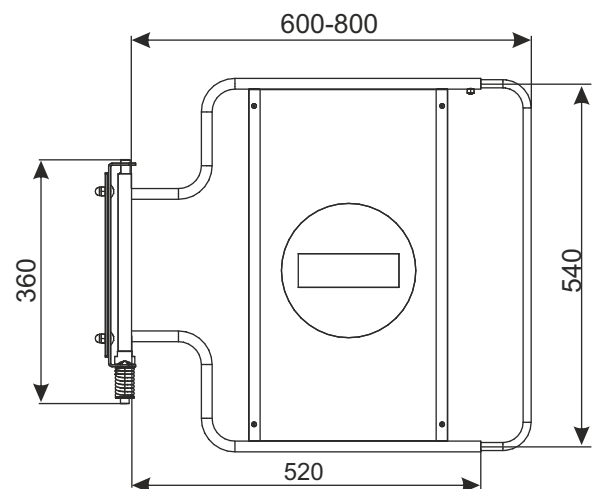

PRODUCT NAME	FINISH	INDEX
Checkout barrier without lock with high bar	chrome	919-320-596

### S CUSTOMER GUIDANCE SYSTEMS

## CHECKOUT BARRIER WITH LOCK WITH HIGH BAR

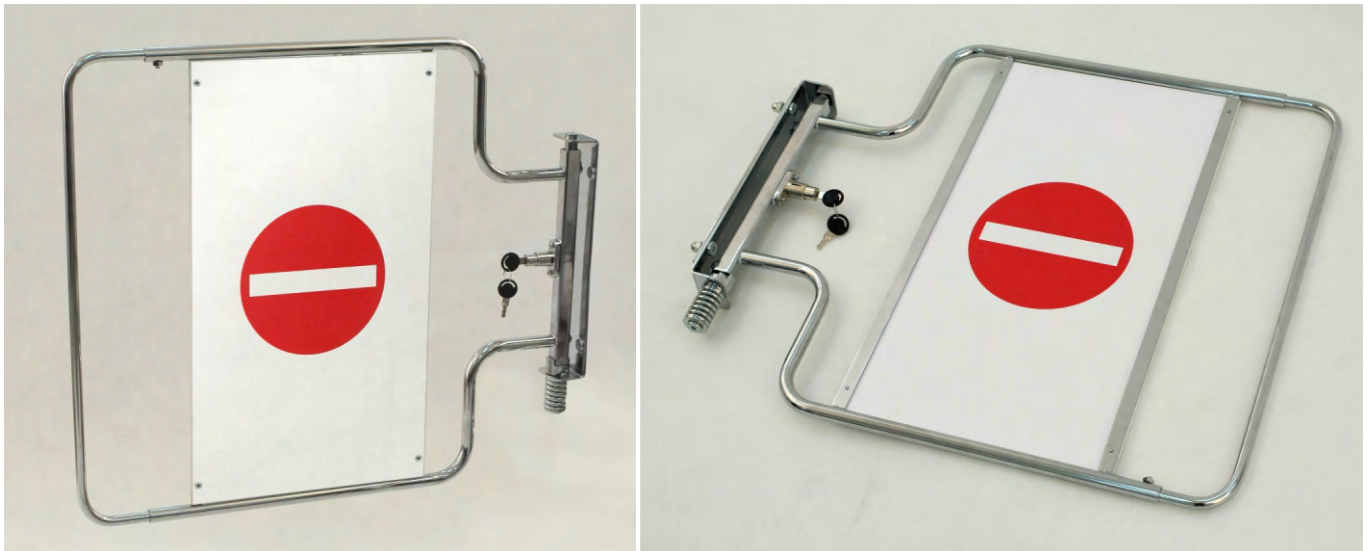

The gate is used in checkouts area.

Bidirectional gate - opens in right side and left side.  
To open or close the gate turn the key in lock, lift the lock and turn the swivel arm in requested direction.

Installed "anty-panic" system prevents from opening a gate in opposite direction. This system allows you to open an emergency gate at the appropriate pressure despite the blockade.

There is possibility of adjusting arm length to 600 mm to 800 mm.

Gateway fixed to the checkout box.

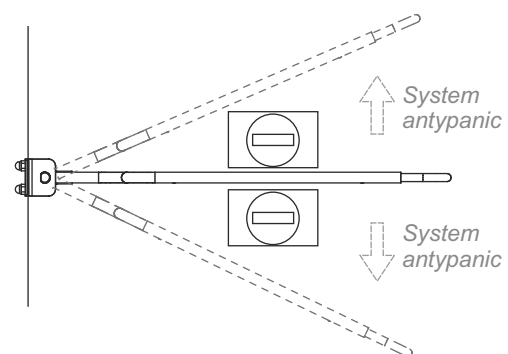
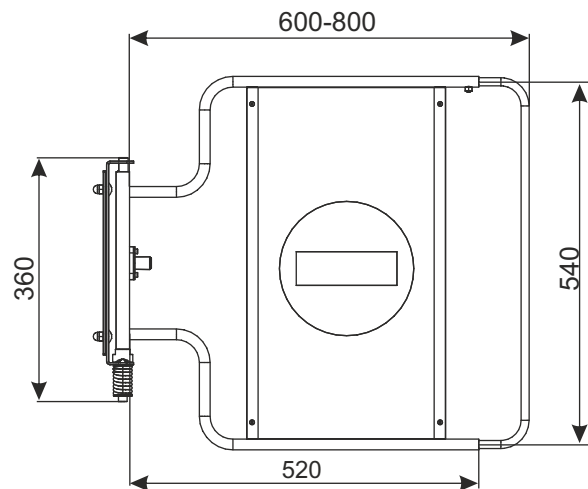

PRODUCT NAME	FINISH	INDEX
Checkout barrier with lock with high bar	chrome	_____

### **S** CUSTOMER GUIDANCE SYSTEMS

## CLAMP FOR FIXING THE CHECKOUT BARRIER

Example of use of the clamp

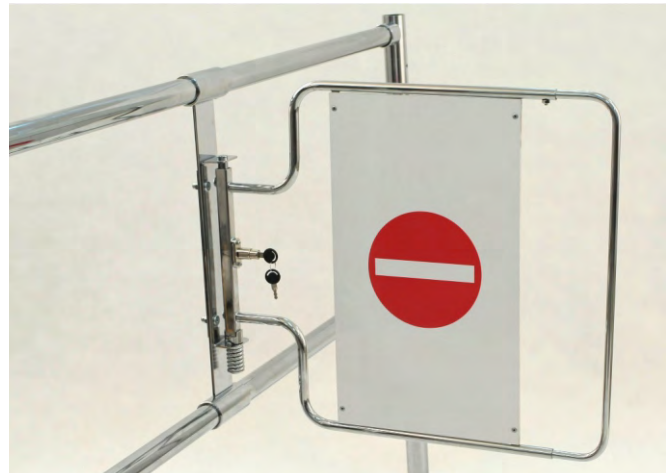
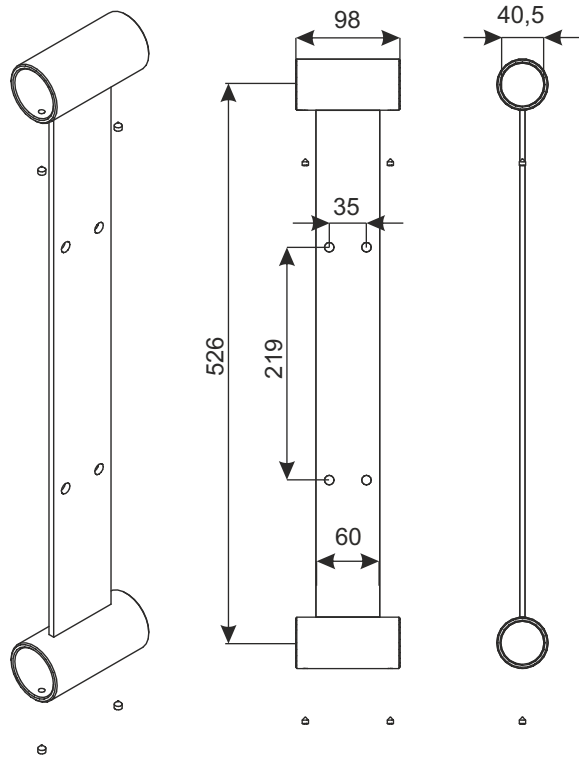

The clamp is used to fix the checkout barrier to the room partition H-1085 mm (gates compatible with the clamp are set out in are specified below). The clamp is applied to the transverse tube of room partition with a diameter of 40mm. Pipes are then bolted together with the partition, and clamp is stiffened by tightening the grub screws. The checkout barrier can be fixed to the clamp from one or both sides.

PRODUCT NAME	FINISH	INDEX
Clamp for fixing the checkout barrier	chrome	919-320-597
BARRIERS COMPATIBLE WITH THE HOLDER	FINISH	INDEX
Checkout barrier without lock	chrome	919-320-557
Checkout barrier with lock	chrome	919-320-594
Checkout barrier without lock with high bar	chrome	919-320-596
Checkout barrier with lock with high bar	chrome	—

### S CUSTOMER GUIDANCE SYSTEMS

## TURNSTILE PORTA'TURNA

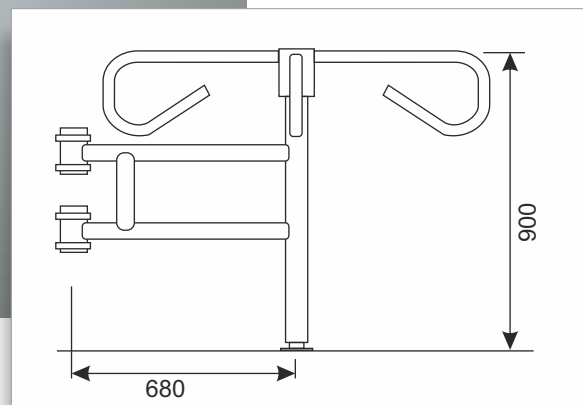
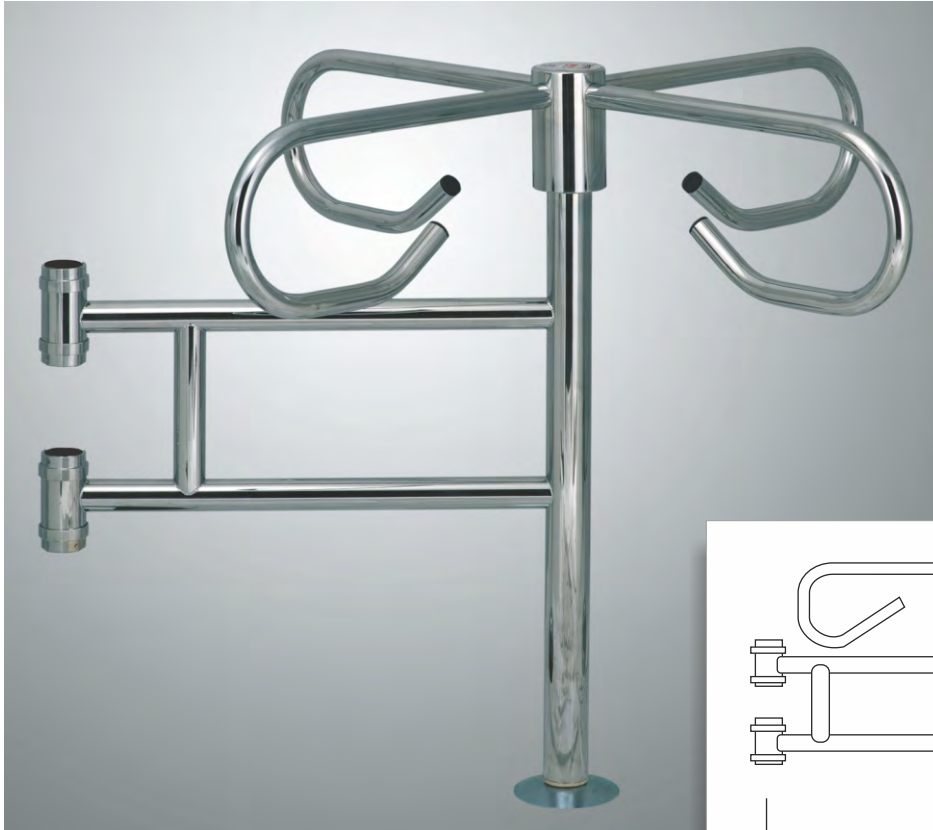

### DIAGRAM OF ASSEMBLY OF THE TURNSTILE WITH OTHER ELEMENTS :

Bottom cover for stand  
made of pipe  $\varnothing 48$  mm

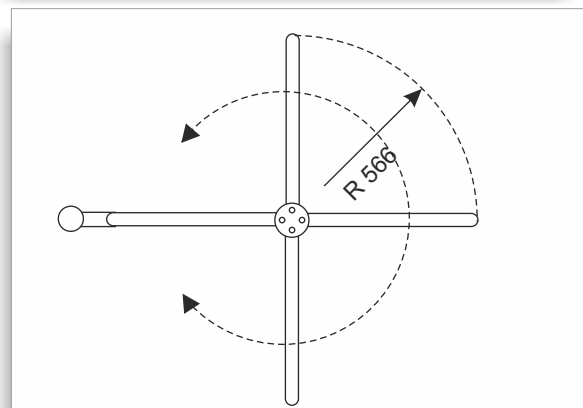
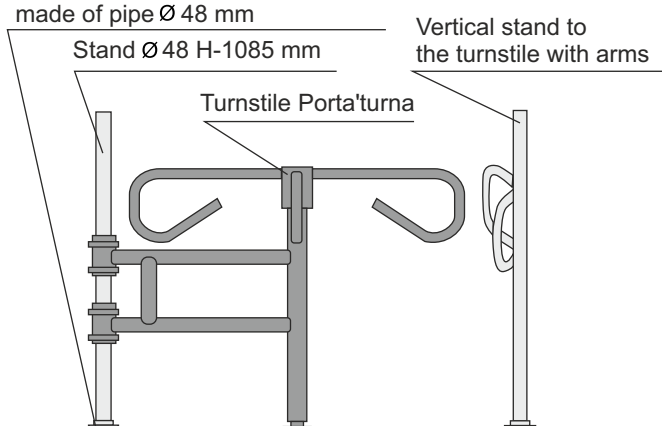

PRODUCT NAME	FINISH	INDEX
Turnstile Porta'turna (left or right)	chrome	07A0016
ELEMENTS MOUNTED WITH THE TURNSTILE	FINISH	INDEX
Vertical stand to the turnstile with arms	chrome	919-320-518
Stand $\varnothing 48$ H-1085 mm	chrome	919-320-408
Bottom cover for stand made of pipe $\varnothing 48$ mm	chrome	919-320-511

## S CUSTOMER GUIDANCE SYSTEMS

## VERTICAL STAND TO THE TURNSTILE WITH ARMS



### DIAGRAM OF ASSEMBLY OF THE TURNSTILE WITH OTHER ELEMENTS:

Bottom cover for stand  
made of pipe  $\varnothing 48$  mm

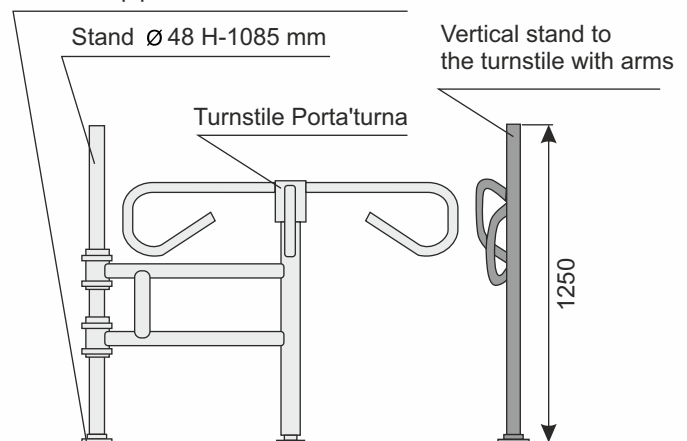

PRODUCT NAME	FINISH	INDEX
Vertical stand to the turnstile with arms	chrome	919-320-518
ELEMENTS MOUNTED WITH THE TURNSTILE:	FINISH	INDEX
Turnstile Porta'turna	chrome	07A0016
Stand $\varnothing 48$ H-1085 mm	chrome	919-320-408
Bottom cover for stand made of pipe $\varnothing 48$ mm	chrome	919-320-511

## S CUSTOMER GUIDANCE SYSTEMS

## TROLLEY PASS L-800 MM/L-1000 MM

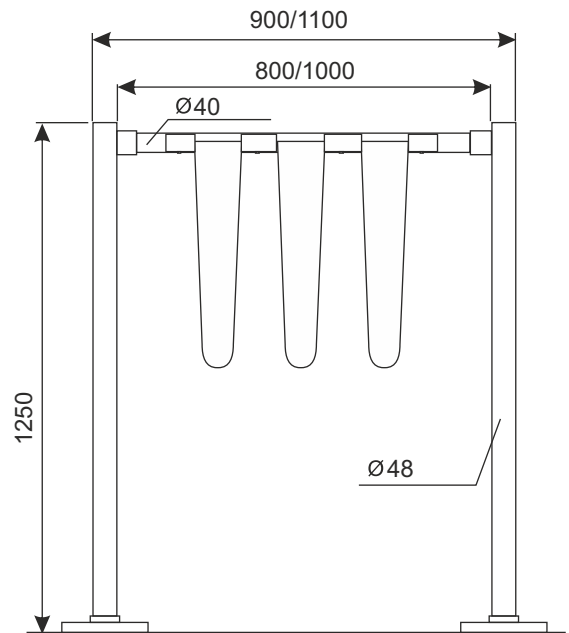

Trolley pass is set of the horizontal tube  $\varnothing 40$  L 800-2000 mm and three plastic "tonques". The gate is mounted to the stands H-1250 mm with the help of joints.

### DIAGRAM OF ASSEMBLY OF THE TROLLEY PASS WITH OTHER ELEMENTS :

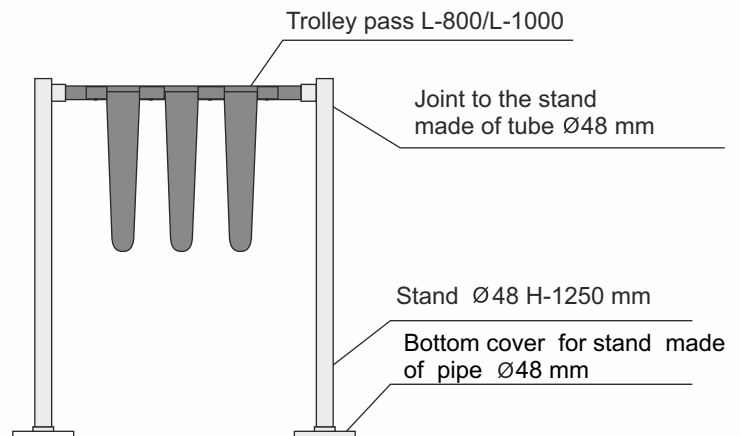

PRODUCT NAME	FINISH	INDEX
Trolley pass L-800/L-1000	chrome	07A0019
ELEMENTS MOUNTED WITH THE TROLLEY PASS	FINISH	INDEX
Joint of plastic in chrom to the stand of tube $\varnothing 48$ mm	—	MUFA_R_D48/D40-CR
Stand $\varnothing 48$ H-1250 mm	chrome	—
Bottom cover for stand made of pipe $\varnothing 48$ mm	chrome	919-320-511

## S CUSTOMER GUIDANCE SYSTEMS

## STAND WITH PULL-OUT STRAP L - 2000 mm

**NEW!**

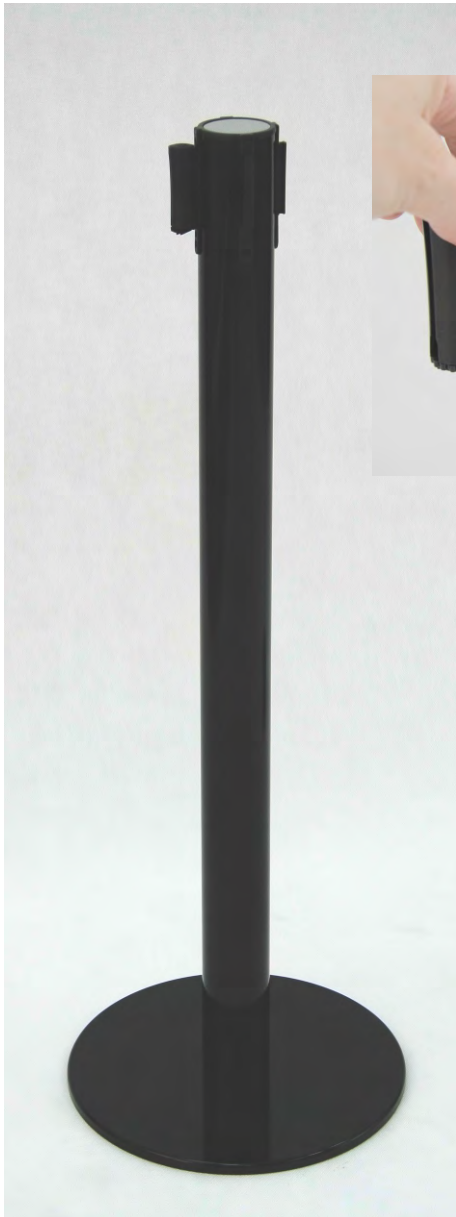

Stand with pull-out strap made of sturdy material and a plastic clasp attached to the second stand allows for fast way to close or open passages or creating a fence with any number of racks.

Large, stable bases do not require attachment to the ground, which makes it possible convenient and quick change of location.

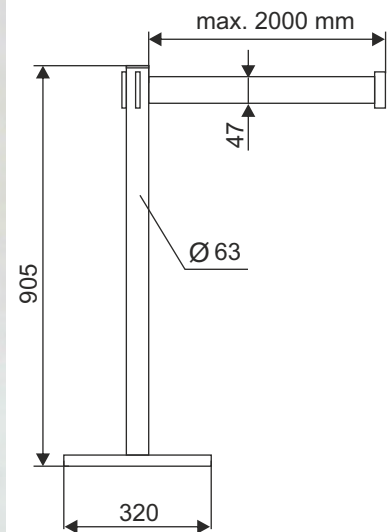

### PRODUCT NAME

Stand with pull-out strap L - 2000 mm

### FINISH

powder coated

### INDEX

—

## **S** CUSTOMER GUIDANCE SYSTEMS



## ROOM PARTITION H 1085



### ELEMENTS OF PARTITION H-1085 mm:

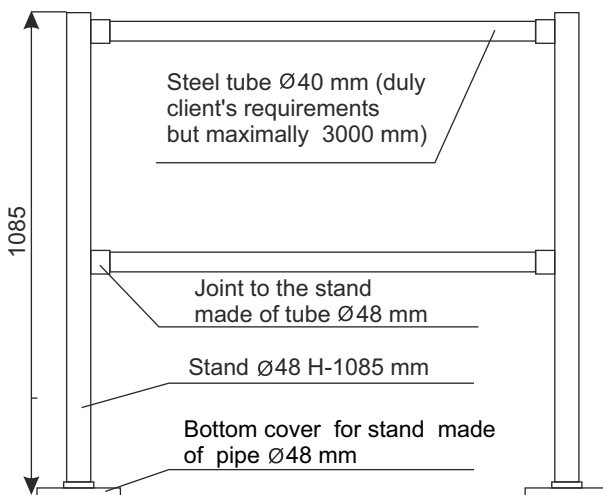

### STAND CONFIGURATIONS H-1085:

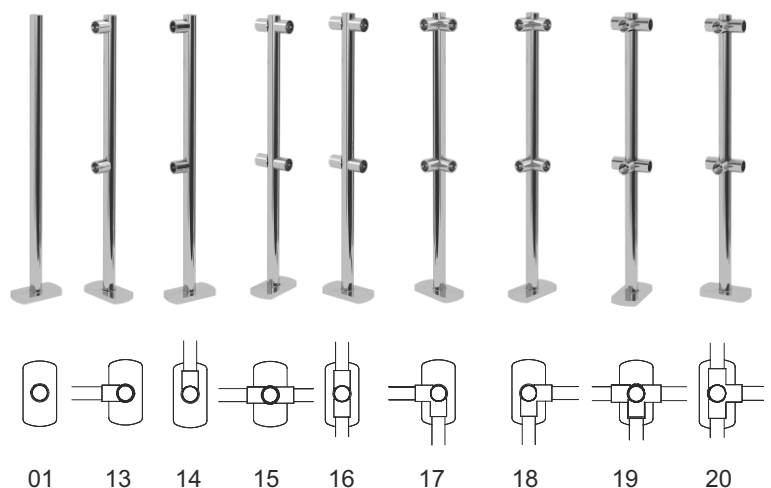

### ELEMENTS OF PARTITION H-1085 mm:

Joint of plastic in chrom to the stand of tube  $\varnothing 48$  mm or joint of plastic in RAL 7042 to the stand of tube  $\varnothing 48$  mm

Stand  $\varnothing 48$  H-1085 mm

Bottom cover for stand made of pipe  $\varnothing 48$  mm

Steel tube  $\varnothing 40$  mm

### FINISH

—

chrome

chrome

chrome

### INDEX

MUFA\_R\_D48/D40-CR

919-320-408

919-320-511

R\_40X1,5-CR

## S CUSTOMER GUIDANCE SYSTEMS

## ENTRY BARRIER WITH BILLBOARD AND FENDER

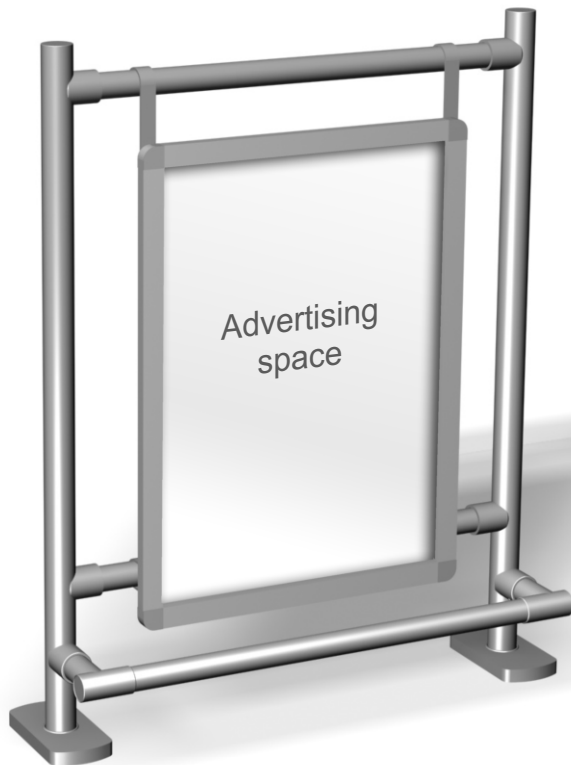

Entry barrier contains:

- room partition H-1085
- billboard 700x500 with holders
- fender fixed to the stand of partition

### Billboard 700x500 with holders:

Intended for graphic in dimensions 700x500 mm, double-sided graphics is visible on both sides on the plate, secured on the outside with transparent foil; aluminium clicker frame, table mounted to partition by handles of sheet metal for tube fi 40 mm, handles are zinc galvanic.

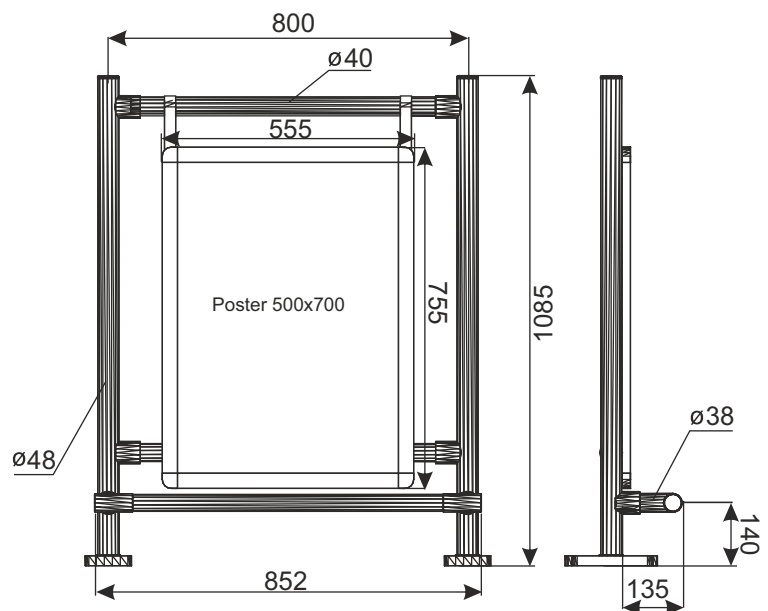

PRODUCT NAME	FINISH	INDEX
Billboard 700x500 with holders	zinc plated + lacquer	919-350-850
Room partition H-1085	chrome	—
Fender fixed to the stand of partition	material - stainless steel	—

## S CUSTOMER GUIDANCE SYSTEMS

## BILBOARD 700X500 WITH HOLDERS



Billboard 700x500 with holders ( poster frame) is mounted to partition H-1085 ( including entry barrier) and it is intended to expose posters located inside the table.

Billboard is intended to graphic in dimensions 700x500 mm, graphic double-sided visible on both sides of plate, protected from outside transparent foil; aluminium clicker frames, table mounted to partition by handles of sheet metal for tube fi 40 mm, handles are zinc galvanic.

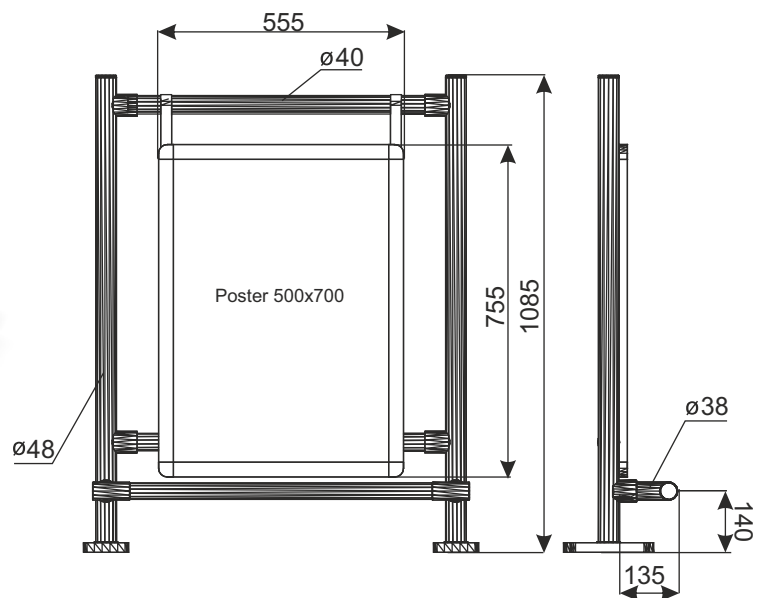
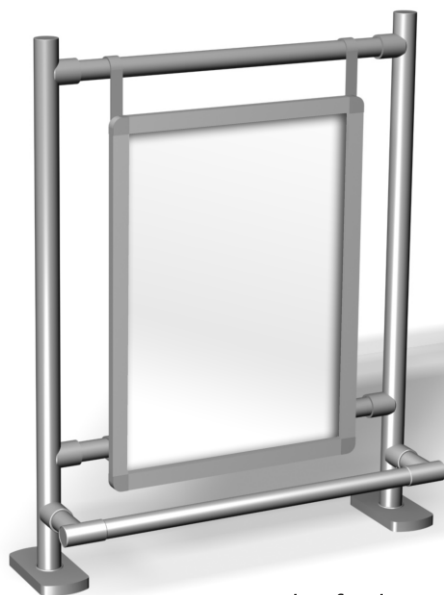

PRODUCT NAME	FINISH	INDEX
Billboard 700x500 with holders	zinc plated + lacquer	919-350-850

### S CUSTOMER GUIDANCE SYSTEMS

## ROOM PARTITION H-2000 (PLEXI WITH CLAMPS)

**NEW!**



### ELEMENTS OF PARTITION H-2000 mm:

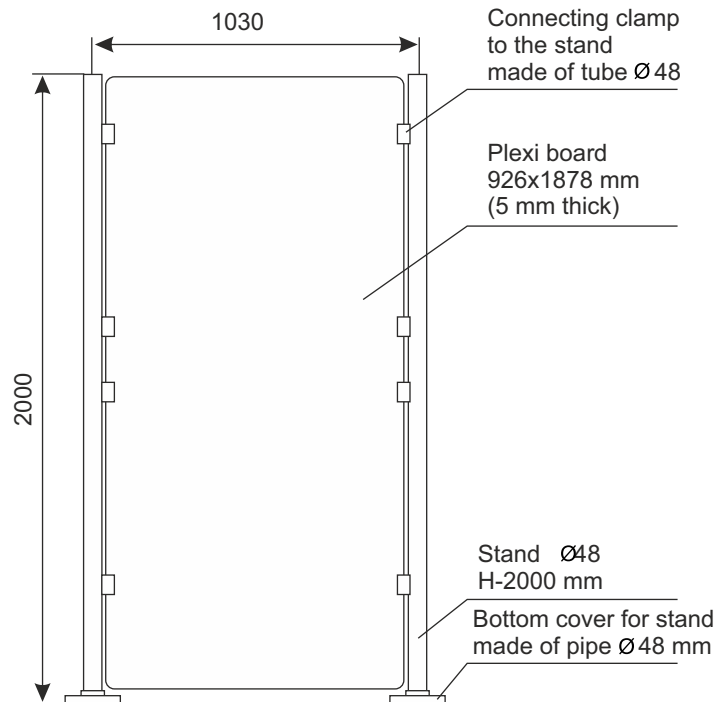

Plexi board 926x1878 mm.

We recommended to use at least 8 clamps for plexi board.

### STAND CONFIGURATIONS H-2000:

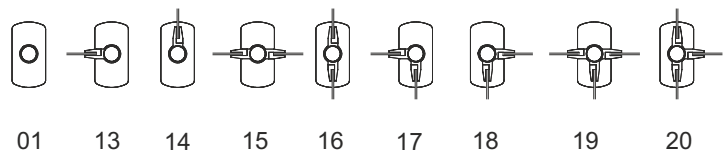

ELEMENTS OF PARTITION H-2000 mm:	FINISH	INDEX
Stand $\varnothing 48$ H-2000 mm	chrome	919-320-409
Bottom cover for stand made of pipe $\varnothing 48$ mm	chrome	919-320-511
Connecting clamp to the stand made of tube $\varnothing 48$	chrome	KLEMMUFA-CR
Plexi board 926x1878 mm	—	PL_5,0X926X1878-P

## S CUSTOMER GUIDANCE SYSTEMS

## ROOM PARTITION H 2000 (GRATE + PLEXI)



### Remarks:

We recommended to use at least 4 clamps for grate and 4 for plexi board.

Wire grate 950x950 Light is made of  $\varnothing 3,3$  mm wire (wire net) and  $\varnothing 9$  mm (frame), net mesh 50x50 mm.

Optionally, instead of the elements: wire grate 950x950 mm Light + Plexi board 1020x950 mm, you can mount the board made of polycarbonate 926x1878 mm. In this case we recommended to use 8 clamps.

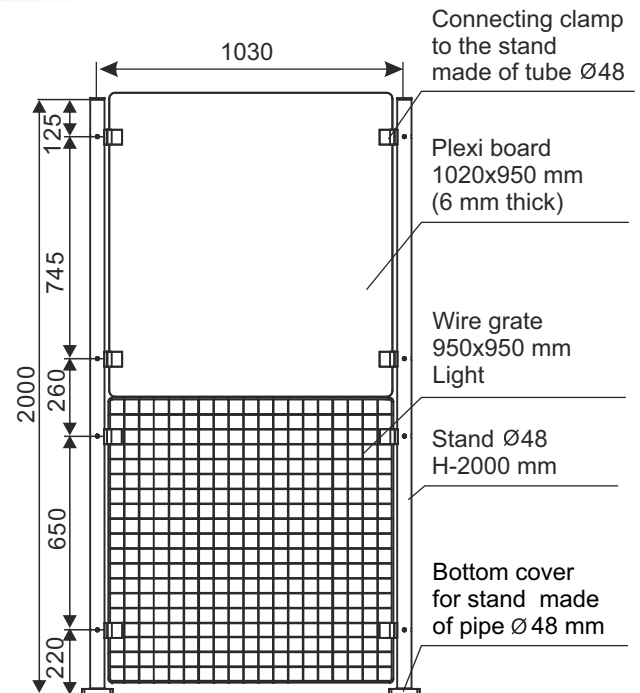

### STAND CONFIGURATIONS H-2000:

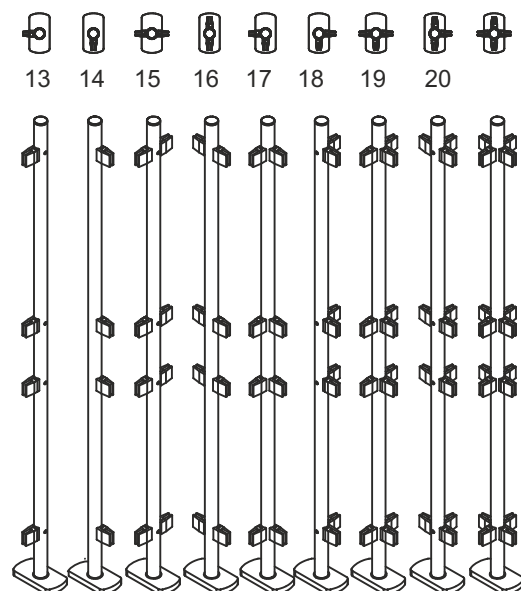

ELEMENTS OF PARTITION H-2000 mm:	FINISH	INDEX
Wire grate 950x950 mm Light	chrome	919-320-438
Plexi board 1020x950 mm	—	Plexi 6x950x1020 R15
Stand $\varnothing 48$ H-2000 mm	chrome	919-320-409
Bottom cover for stand made of pipe $\varnothing 48$ mm	chrome	919-320-511
Connecting clamp to the stand made of tube $\varnothing 48$	chrome	KLEMMUFA-CR
Board made of polycarbonate 926x1878 mm (optional)	—	PL_5,0X926X1878-P

## S CUSTOMER GUIDANCE SYSTEMS

## TIGHT PARTITION WITH THE FULL BOTTOM



Tight partition with the full bottom is designed to organize the shops open space.

### Realization

Elements:

- transparent board made of non-flammable polycarbonate, 5 mm thick, dimensions 926x1878 mm,
  - stand H-2000 mm  $\varnothing 48 \times 2,0$  with a slat,
  - elements of the stand (base, cap, connector)
- Partition is fixed to the ground with anchor.

### Dimensions:

Partition's height - 2000 mm,  
Spacing on stands - 1000 mm

### Finish:

Stand and the slat - chrome,  
Base - electroplated with zinc.

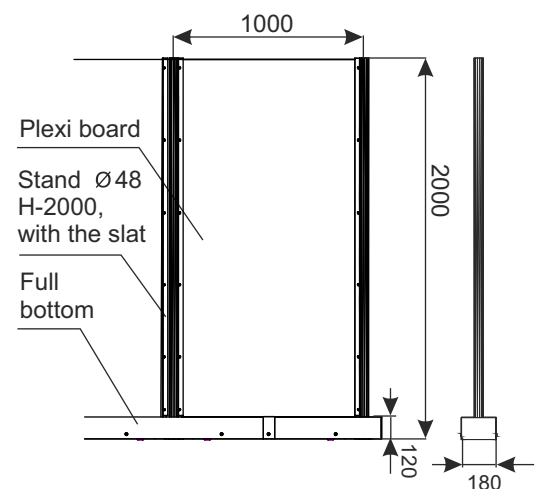
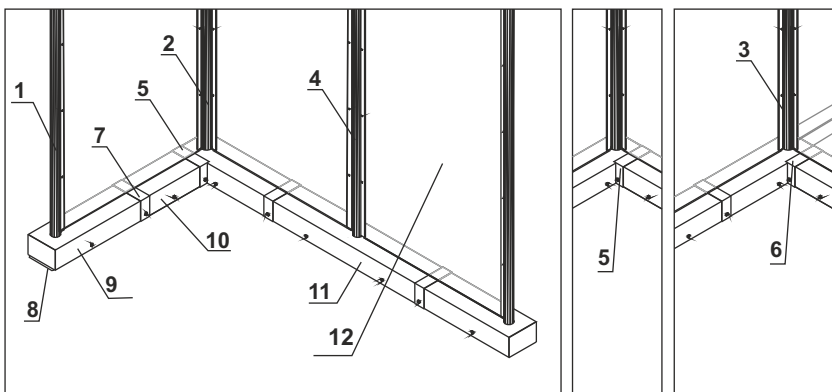

ELEMENTS	FINISH	INDEX
1. Finishing stand	chrome	919-320-548
2. Corner stand	chrome	919-320-549
3. Middle corner stand	chrome	919-320-552
4. Middle stand	chrome	919-320-547
5. Corner connector	zinc plated + lacquer	919-350-870
6. Middle corner connector	zinc plated + lacquer	919-350-869
7. Middle connector	zinc plated + lacquer	919-350-864
8. Base	zinc plated + lacquer	919-350-860
9. Finish cap	zinc plated + lacquer	919-350-863
10. Short cap	zinc plated + lacquer	919-350-862
11. Middle cap	zinc plated + lacquer	919-350-861
12. Board made of polycarbonate 926x1878 mm	_____	PL_5,0X926X1878-P

## S CUSTOMER GUIDANCE SYSTEMS

## FENDER NEAR THE FLOOR



### DIAGRAM OF FENDER'S ELEMENTS:

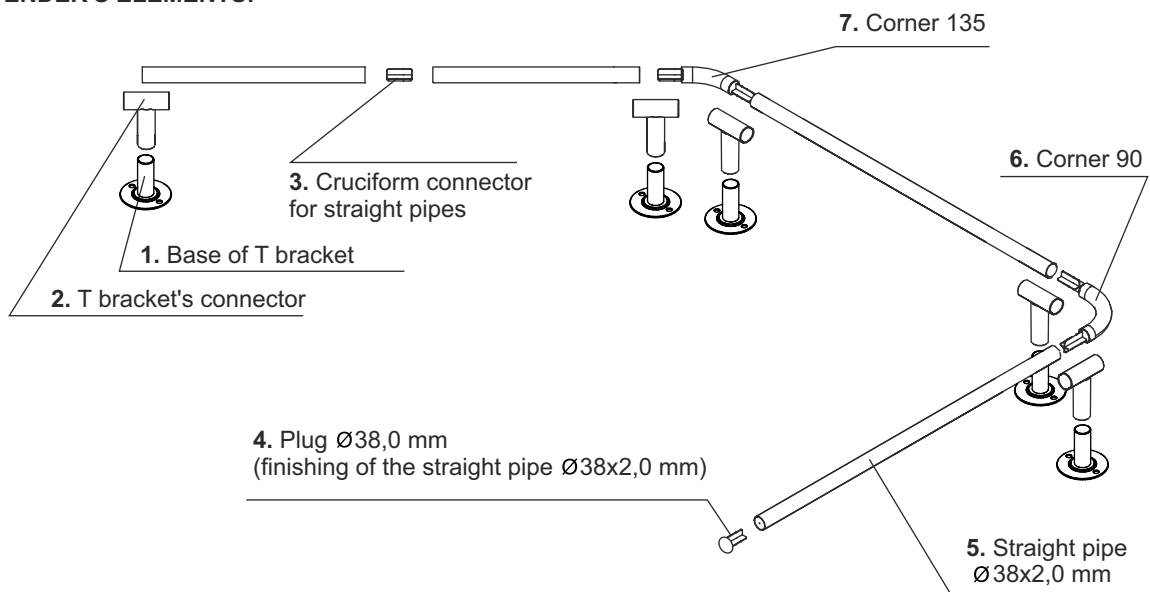

ELEMENTS OF THE FENDER NEAR THE FLOOR:	FINISH	INDEX
Bracket T: 1. Base of T bracket 2. T bracket's connector	material - stainless steel	919-380-683
3. Cruciform connector for straight pipes	material - stainless steel	919-380-678
4. Plug Ø38,0 mm (finishing of the straight pipe Ø38x2,0 mm)	material - stainless steel	919-380-681
5. Straight pipe Ø38x2,0 mm	material - stainless steel	R_A2_38x2,0-SZ320
6. Corner 90 (with cruciforms)	material - stainless steel	919-380-685
7. Corner 135 (with cruciforms)	material - stainless steel	919-380-687

## S CUSTOMER GUIDANCE SYSTEMS

## FENDER FIXED TO THE STAND

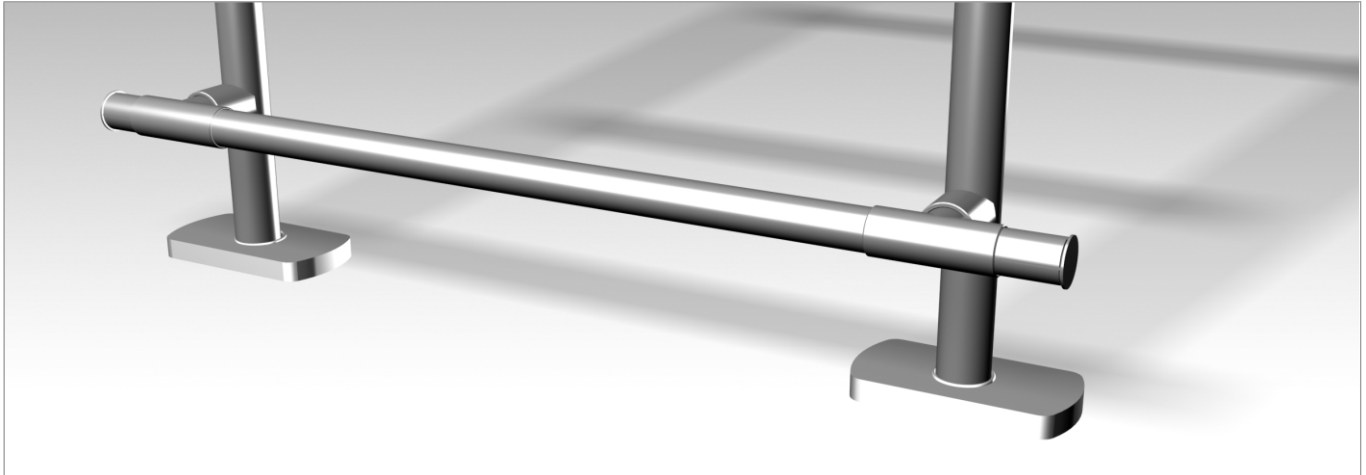

### DIAGRAM OF FENDER'S ELEMENTS:

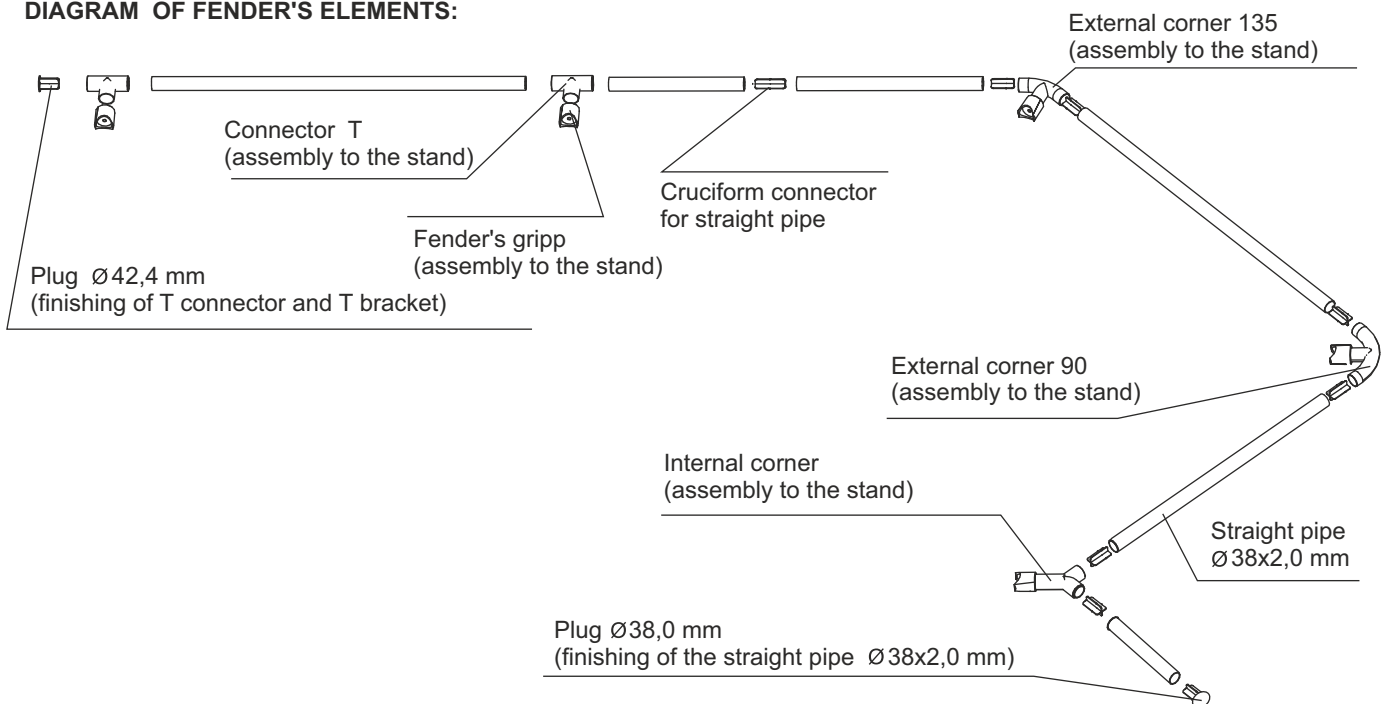

ELEMENTS OF THE FENDER FIXED TO THE STAND:	FINISH	INDEX
Connector T (assembly to the stand)	material - stainless steel	919-380-677
Internal corner (assembly to the stand)	material - stainless steel	—
External corner 135 (assembly to the stand)	material - stainless steel	—
External corner 90 (assembly to the stand)	material - stainless steel	—
Fender's gripp(assembly to the stand)	chrome	919-320-542
Cruciform connector for straight pipe	material - stainless steel	919-380-678
Plug Ø 42,4 mm (finishing of T connector and T bracket)	material - stainless steel	—
Plug Ø38,0 mm (finishing of the straight pipe Ø38x2,0 mm)	material - stainless steel	919-380-681
Straight pipe Ø38x2,0 mm	material - stainless steel	R_A2_38x2,0-SZ320

## S CUSTOMER GUIDANCE SYSTEMS



## ACCESSORIES TO FENDERS



Joint of plastic in chrom to the stand of tube Ø48 mm

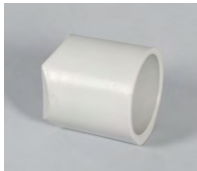

Joint of plastic in RAL 7042 to the stand of tube Ø48 mm

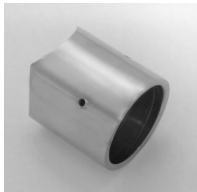

Joint of metal to the electronic entrance ( Ø120 mm)



A plane joint to the electronic entrance Porta'e2



Connecting clamp to the stand made of tube Ø48 mm



A round, plastic, gray insert with overprint of Produx mark (to the stand of tube Ø48 mm)



A round, black insert (to the stand of tube Ø48 mm)



Anchor sleeve

PRODUCT NAME	FINISH	INDEX
Joint of plastic in chrom to the stand of tube Ø48 mm	—	MUFA_R_D48/D40-CR
Joint of plastic in RAL 7042 to the stand of tube Ø48 mm	—	—
Joint of metal to the electronic entrance (Ø120 mm)	—	—
A plane joint to the electronic entrance Porta'e2	—	—
Connecting clamp to the stand made of tube Ø48 mm	chrome	KLEMMUFA-CR
A round, plastic, gray insert with overprint of Produx mark (to the stand of tube Ø48 mm)	—	WKPO_48-42X15+5_PSNP
A round, black insert ( to the stand of tube Ø48 mm)	—	—
Anchor sleeve	zinc plated	SŁ1R_M10X110/12X50ZN

## S CUSTOMER GUIDANCE SYSTEMS

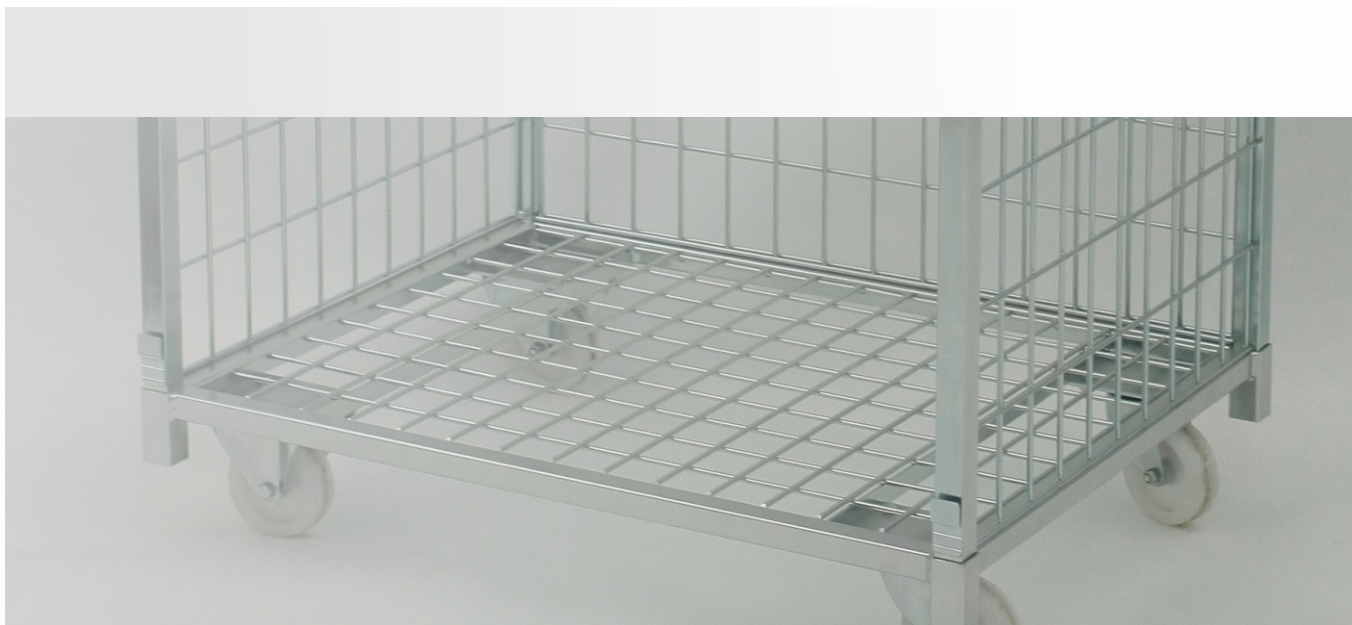

## ROLLCONTAINERS

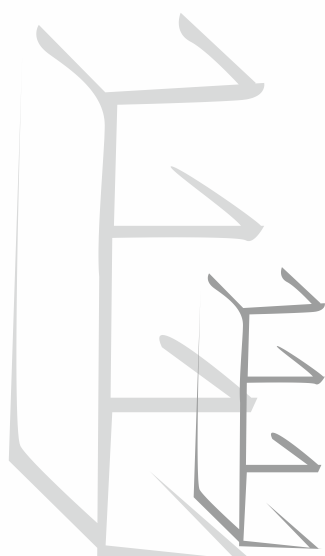

## K ROLLCONTAINERS

- 1 Container 855x655 H1400
- 2 Low container 880x460 H-1240
- 3 High Container 700x700 H-1650
- 4 Container 800x700x1500 with front doors
- 5 Container WMU 1700x800x600
- 6 Folding container WMS 1800x810x750
- 7 Container for logistic KL-1200x800x1950
- 8 Folding container for logistic KLS 1200x800x2000
- 9 Folding container for logistic KLS-2 600x800x1800
- 10 Kontener logistyczny składany KLS-3 700X800X1900
- 11 Folding container for logistic KLS-4 860x730x1900
- 12 Container for logistic KLS-C 600x800x1800
- 13 Container 800X600 H1810 with bottom frame „Z”
- 14 Warehouse trolley 810x720 H1700
- 15 Warehouse trolley 810x720 H1900
- 16 Container for cartons 600x1000 H1200
- 17 Container for cartons 800x1200 H1200
- 18 Container KK-1015x800x600
- 19 Container with 3 shelves 1100x600 H-1600
- 20 Container with 3 shelves 1100x750 H-1600
- 21 Warehouse trolley
- 22 Warehouse trolley with basket 800x600 H600 on wheels
- 23 Warehouse trolley with basket 800x600 H600 with frame on wheels
- 24 Steel mobile pallet 600x400 mm

*The reproduce without prior permission is forbidden. In order to improve, the manufacturer reserves the right to implement modifications in its products. Recommendations for installation and use the products are provided for informational purposes only and does not imply any liability on the part of the manufacturer.*

## K ROLLCONTAINERS

## CONTAINER 855X655 H1400



The container can be used, among others for packaging orders.

**Technical data:** The stability of the structure is ensured by closed profiles, mesh made of steel bars, bottom with wheels (two fixed wheels, two swivel wheels with brakes), hanged shelves, reinforced with flat bars. It is possible to adjust the height of the shelves.

The container has a handle on the side for easy handling, hooks for bags and as an optional equipment a tablet pad.

**Standard finish:** zinc plated + lacquer.

**Wheels diameter:** 100 mm

**Loading of shelf:** 50 kg

**Total loading:** 300 kg

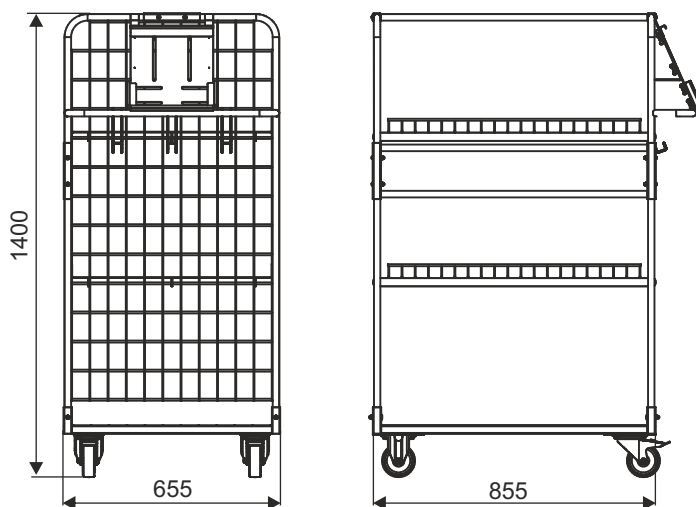

**total max.**

**300 kg**

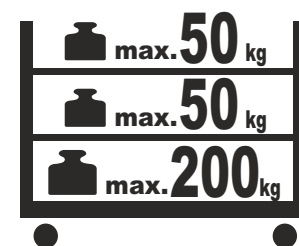

PRODUCT NAME	FINISH	INDEX
Container 855x655 H1400	zinc plated + lacquer	919-351-424

### **K** ROLLCONTAINERS

## LOW CONTAINER 880X460 H-1240



Container allows for presentation of commodities. The construction of the container is folded and bolted. The supporting construction is made of a section bar, shelves made of wire. The possibility of height adjustment of the shelves position within the container. Shelf adjustment step 110 mm. Shelves lined with Plexiglas to protect it from falling out of small products. Additionally, plexiglass shelves are lined with non-slip grooved rubber. Swivel castors, including 2 pcs. with brake. Optional accessories: basket for code reader.

**Finish:** zinc plated + lacquer.  
**Wheel diameter:** 100 mm  
**Total loading:** 200 kg  
**Loading of shelf:** 50 kg

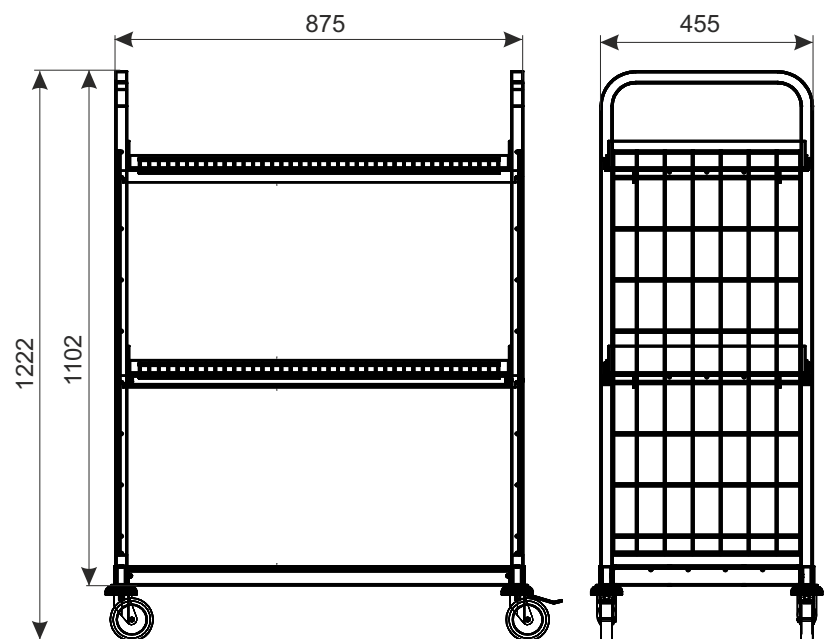

PRODUCT NAME	FINISH	INDEX
Low container 880x460 H-1240	zinc plated + lacquer	919-351-247

### **K** ROLLCONTAINERS

## HIGH CONTAINER 700X700 H-1650



Container allows for presentation of commodities. The construction of the container is folded and bolted. The supporting construction is made of a section bar, shelves made of wire reinforced with flat bars. The possibility of height adjustment of the shelves position within the container. Shelves and base lined with Plexiglas to protect it from falling out of small products. Swivel castors, including 2 pcs. with brake. Optional accessories: basket for code reader and a holder for plastic bags.

**Finish:** zinc plated + lacquer  
**Wheel diameter:** 100 mm  
**Total loading:** 250 kg  
**Loading of shelf:** 50 kg

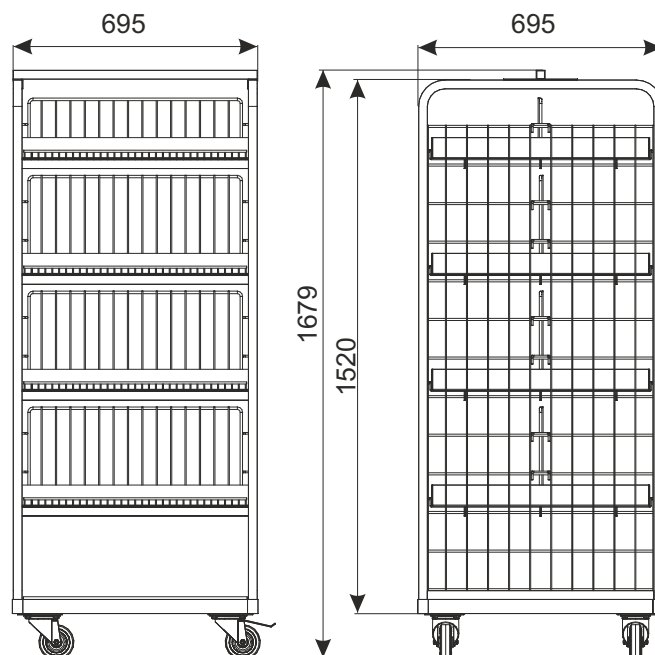

PRODUCT NAME	FINISH	INDEX
High Container 700x700 H-1650 (3 shelves)	zinc plated + lacquer	919-351-251
High Container 700x700 H-1650 (4 shelves)	zinc plated + lacquer	919-351-252

### **K** ROLLCONTAINERS

## CONTAINER 800X700X1500 WITH FRONT DOORS



Roll Cages are movable containers for various purposes. Shops, shopping centers and warehouses are places where roll cages with success prove correct as the universal containers for selling, presentations and transporting of the goods. They can be useful for laundries as containers for transporting underwear, clothing, etc. Simple structure and functionality together with wide range of application decide about popularity of this item among our Customers.

**Finish:** zinc plated + lacquer

**Technical data:** structure of roll cage made of pipes and steel meshes, bottom made of steel wire, bottom with wheels.

**Wheel:** diameter 125 mm.

**Total loading:** 300 kg

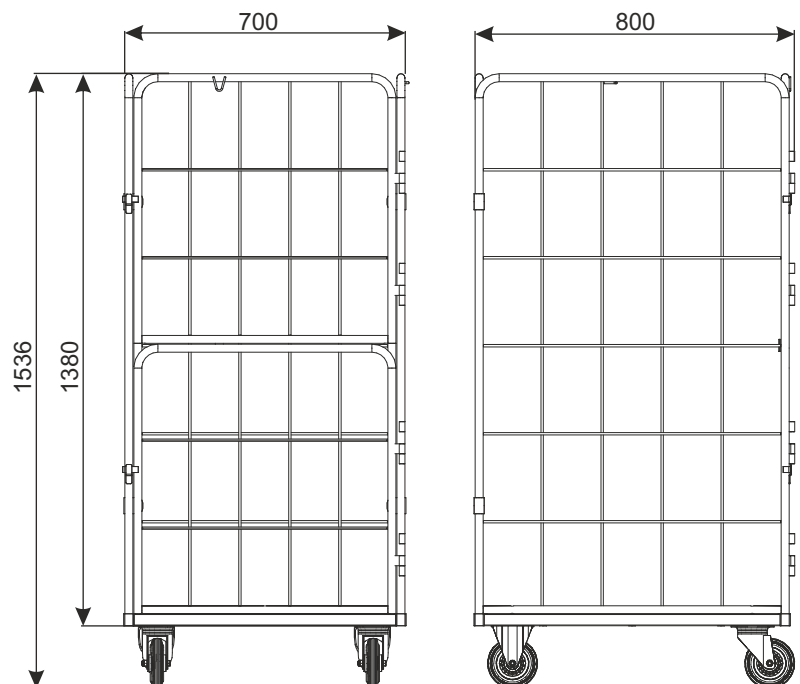

PRODUCT NAME	FINISH	INDEX
Container 800x700x1500 with front doors	zinc plated + lacquer	919-351-248

### **K** ROLLCONTAINERS

## UNIVERSAL CONTAINER WMU-1700X800X600



**Standard finish:** zinc plated + lacquer.

**Technical data:** closed profiles (rectangular) ensure stability of structure, side meshes are made of steel wires, bottom with wheels. Reinforced shelves, the ability to quickly move the shelves. The construction allows for using a shelf as front wall of the container. As a standard there are 2 shelves in the set.

**Finish:** zinc plated + lacquer  
**Wheel:** diameter 100, poliamid  
**Loading of shelf:** 50 kg  
**Total loading:** 250 kg

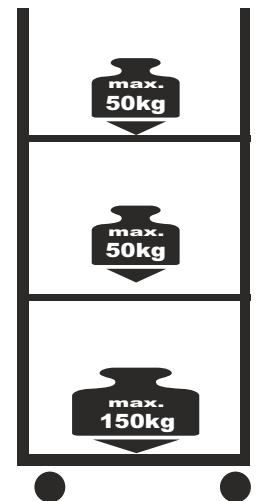
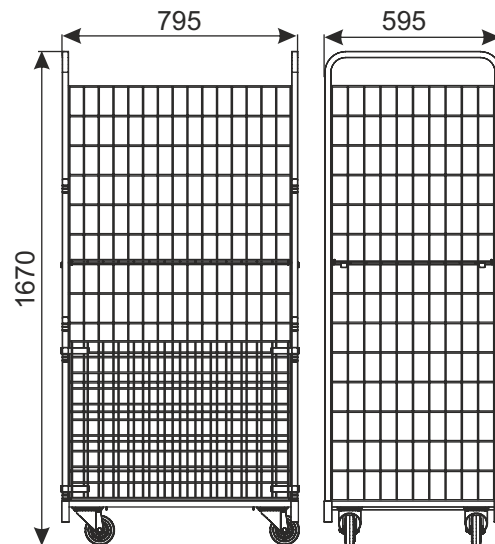

### POSSIBLE CONFIGURATIONS:

Version without shelves

Version with one shelf put on vertically

Version with two shelves put on vertically

Version with two shelves put on vertically and horizontally

Version with two shelves put on horizontally



PRODUCT NAME	FINISH	INDEX
Universal container WMU-1700x800x600 (with 2 shelves)	zinc plated + lacquer	919-351-137

### **K** ROLLCONTAINERS



## FOLDING CONTAINER WMS-1800X810X750



Roll Cages are movable containers for various purposes. Shops, shopping centers and warehouses are places where roll cages with success prove correct as the universal containers for selling, presentations and transporting of the goods. They can be useful as well as the garbage bin. Simple structure and functionality together with wide range of application decide about popularity of this item among our Customers.

**Standard finish:** zinc plated + lacquer.  
**Technical data:** structure of roll cage made of pipes and steel meshes, bottom and shelves made of steel wire, bottom with wheels.  
**Wheel diameter:** 125 mm.  
**Total loading:** 200 kg.  
**Loading of shelf:** 50 kg

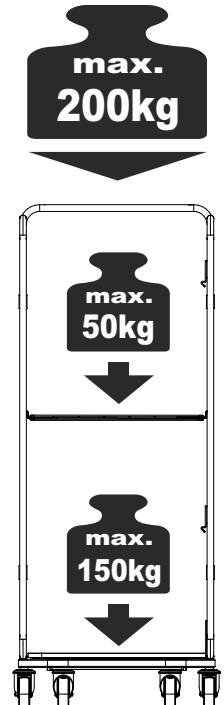
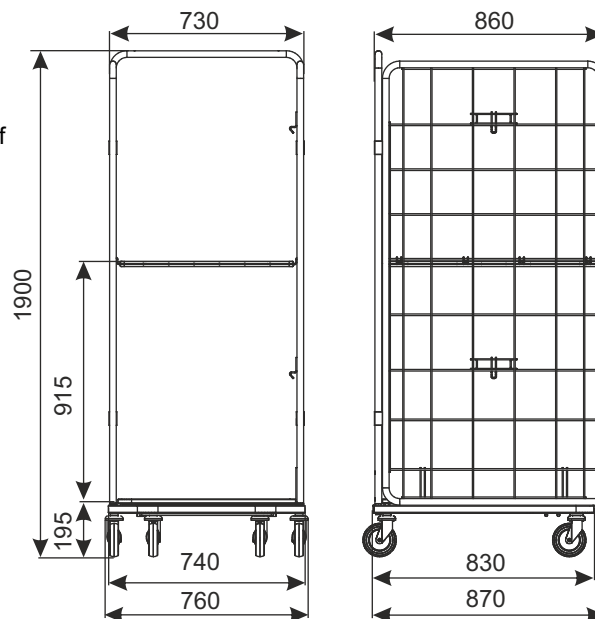
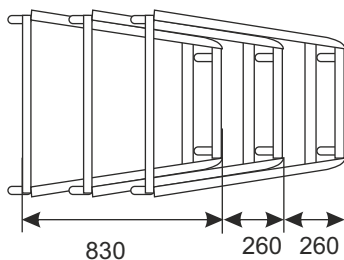

PRODUCT NAME	FINISH	INDEX
Folding container WMS 1800x810x750	zinc plated + lacquer	919-351-227

### K ROLLCONTAINERS

## CONTAINER FOR LOGISTIC KL-1200x800x1950

**NEW!**



### Technical data:

- Structure made of closed profiles, mesh made of steel bars. Base made of plywood (anti-slip, waterproof, double-sided foiled), fitted with 4 swivel castors.
- Two wheel lock systems - directional lock on two wheels (allows stable guidance when container is heavily loaded) and travel lock acting as brake to prevent container from moving on its own.
- Handle on the side of the container - for easier transport of the container.
- Straps with safety fasteners - 3 pcs. - securing the goods against falling out of the container.
- Pocket on the left side - allows the insertion of a label/ A6 sheet.

**Finish:** zinc plated + lacquer

**Wheel:** diameter 125 mm

**Nesting distance:** 160 mm

**Total loading:** 500 kg

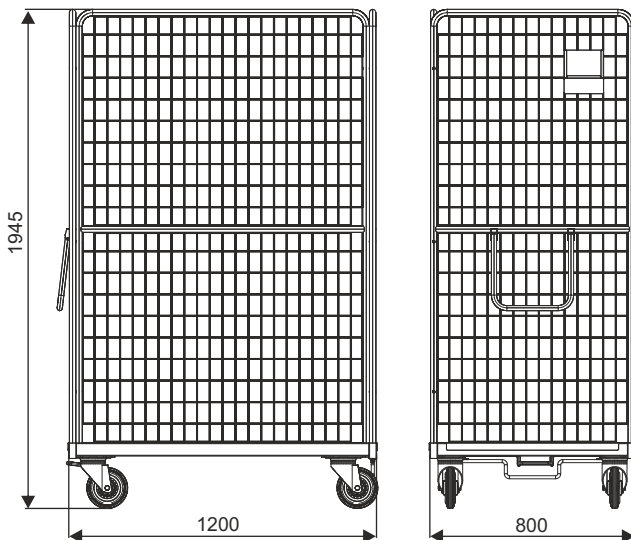

PRODUCT NAME	FINISH	INDEX
Container for logistic KL-1200x800x1950	zinc plated + lacquer	919-351-623

### **K** ROLLCONTAINERS

## FOLDING CONTAINER FOR LOGISTIC KLS 1200X800X2000



**Technical data:** the stability of construction is provided by closed profiles, nets made of steel bars, bottom with wheels (2 fixed wheels, 2 swivel wheels with brakes), bottom shelf is reinforced with flat bars. The container has a double front hinged door which, when closed, forms the front wall of the container. The upper shelf is folded. The construction of container allows for its folding and nesting of folding containers.

**Finish:** zinc plated + lacquer

**Wheel:** diameter 125 mm

**Nesting distance:** 290 mm

**Loading of shelf:** 100 kg

**Total loading:** 500 kg

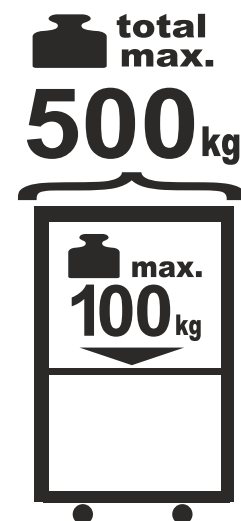
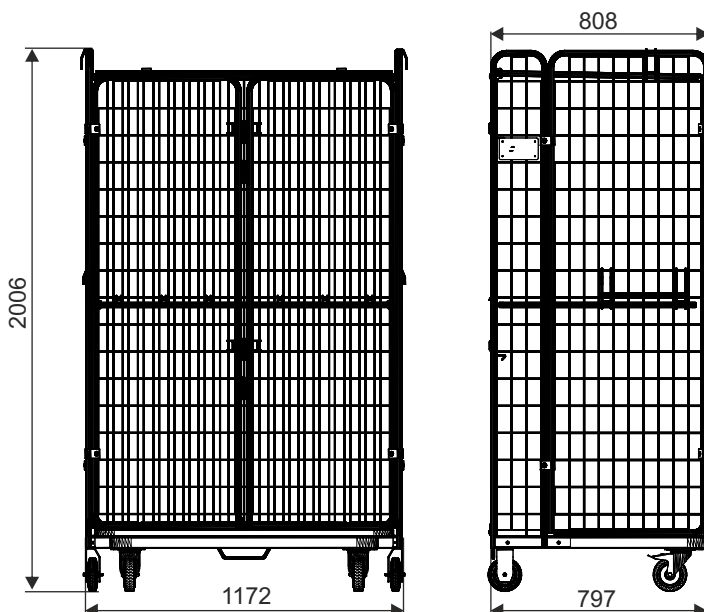
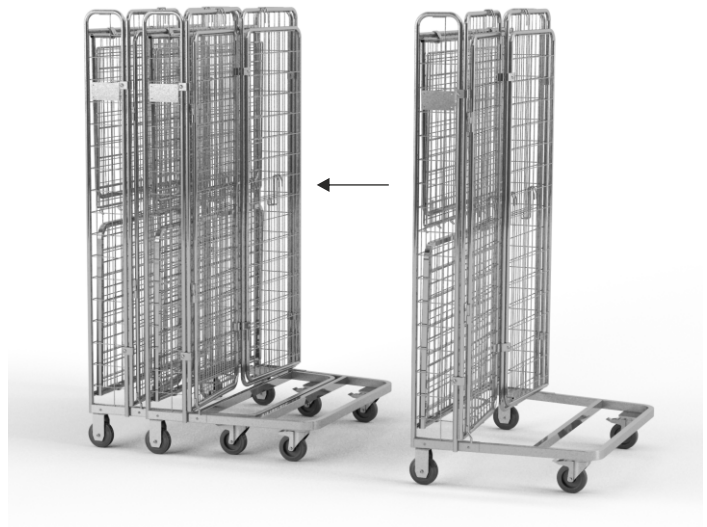

PRODUCT NAME	FINISH	INDEX
Folding container for logistic KLS 1200x800x2000	zinc plated + lacquer	—

### **K** ROLLKONTENERY

## FOLDING CONTAINER FOR LOGISTIC KLS-2 600X800X1800

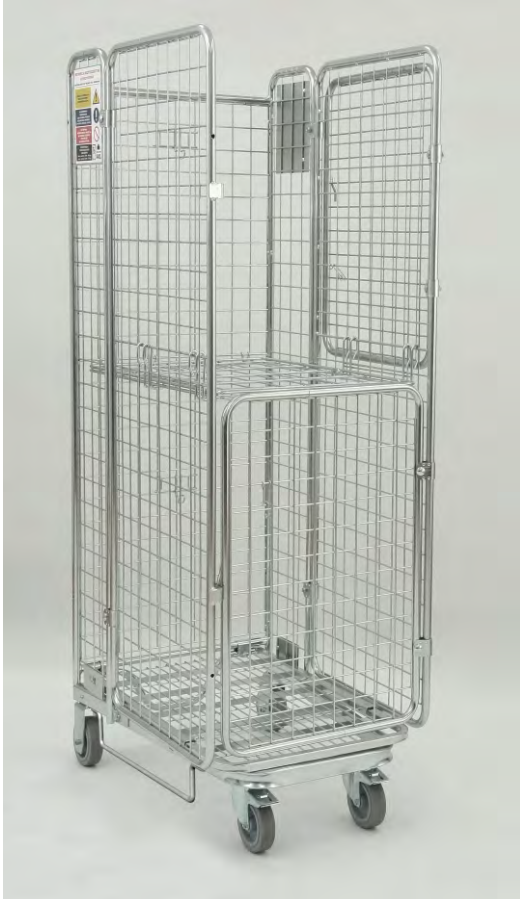

**Technical data:** the stability of construction is provided by closed profiles, nets made of steel bars, bottom with wheels (2 fixed wheels, 2 swivel wheels with brakes), bottom shelf is reinforced with flat bars. Container has two front, adjustable doors (upper and bottom) which can be closed independently of each other creating the front wall of the container. The upper shelf is folded. The construction of container allows for its folding and nesting of folding containers.

**Finish:** zinc plated + lacquer

**Wheel:** diameter 125 mm

**Nesting distance:** 320 mm

**Loading of shelf:** 150 kg

**Total loading:** 400 kg

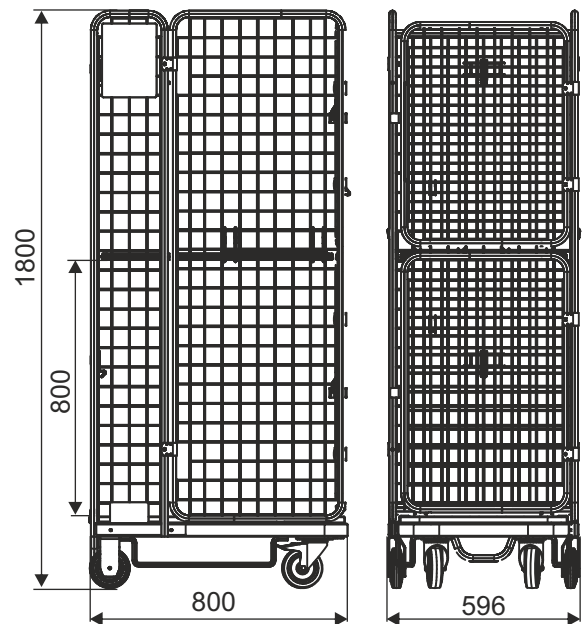

### POSSIBLE CONFIGURATIONS:

Container with open door

Container with 1 closed door

Container with 2 closed doors

Container with raised shelf

The possibility of nesting folding containers



PRODUCT NAME	FINISH	INDEX
Folding container for logistic KLS-2 600x800x1800	zinc plated + lacquer	919-351-321

### **K** ROLLCONTAINERS

## FOLDING CONTAINER FOR LOGISTIC KLS-3 700X800X1900



**Technical data:** the stability of construction is provided by closed profiles, nets made of steel bars, bottom with wheels (2 fixed wheels, 2 swivel wheels with brakes), bottom shelf is reinforced with flat bars. Container has front door which can be closed creating the front wall of the container. The upper shelf is folded. The construction of container allows for its folding and nesting of folding containers.

**Finish:** zinc plated + lacquer

**Wheel:** diameter 125 mm

**Nesting distance:** 230 mm

**Loading of shelf:** 75 kg

**Total loading:** 450 kg

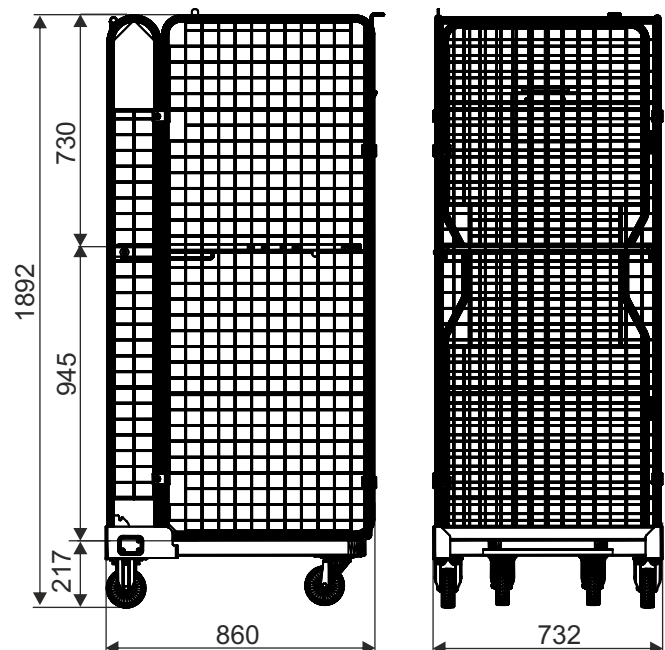
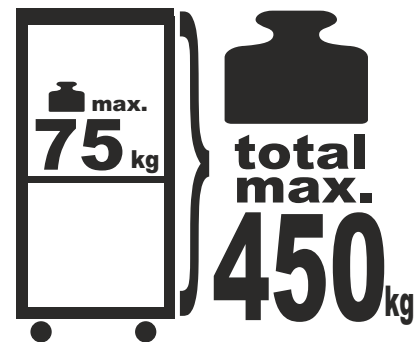

PRODUCT NAME	FINISH	INDEX
Folding container for logistic KLS-3 700x800x1900	zinc plated + lacquer	919-351-517

### **K** ROLLCONTAINERS

## FOLDING CONTAINER FOR LOGISTIC KLS-4 860x730x1900

**NEW!**



**Technical data:** the stability of construction is provided by closed profiles, nets made of steel bars, bottom with wheels (2 fixed wheels, 2 swivel wheels with brakes), bottom shelf is reinforced with flat bars.

Folding shelves (lifted upwards). A wire lid at the top of the container and a handle with a padlock on the door allows you to protect the contents of the container against being taken by unauthorized persons.

Container has front door which can be closed creating the front wall of the container. The construction of container allows for its folding and nesting of folding containers.

**Finish:** zinc plated + lacquer

**Wheel:** diameter 125 mm

**Nesting distance:** 230 mm

**Loading of shelf:** 75 kg

**Total loading:** 450 kg

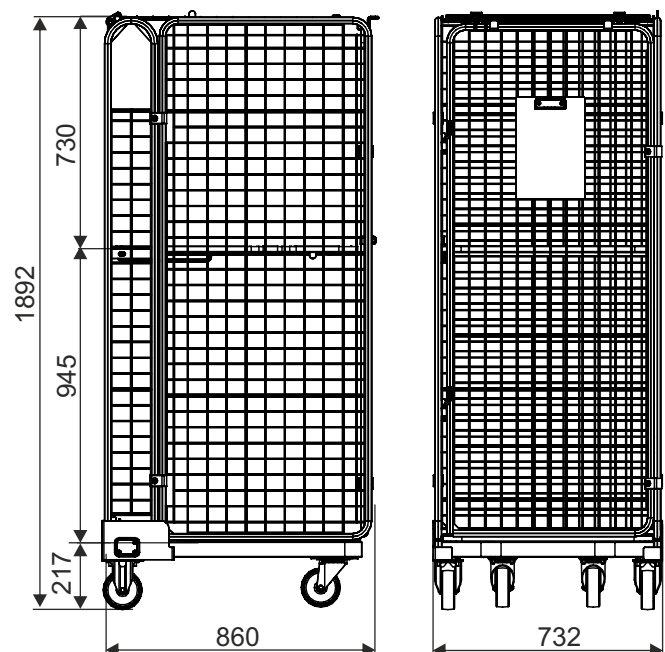

### PRODUCT NAME

Folding container for logistic KLS-4 860x730x1900

### FINISH

zinc plated + lacquer

### INDEX

919-351-565

## **K** ROLLCONTAINERS

## CONTAINER FOR LOGISTIC KLS-C 600X800X1800



**Technical data:** the stability of construction is provided by closed profiles, nets made of steel bars, bottom with wheels (2 fixed wheels, 2 swivel wheels with brakes), the wire base is reinforced with flat iron. Container has two front, adjustable doors (upper and bottom) which can be closed independently of each other creating the front wall of the container. Two wire shelves permanently attached to the container, the ability to raise them when not in use.

### POSSIBLE CONFIGURATIONS:



**Finish:** zinc plated + lacquer  
**Wheel:** diameter 125 mm  
**Loading of shelf:** 75 kg  
**Total loading:** 400 kg

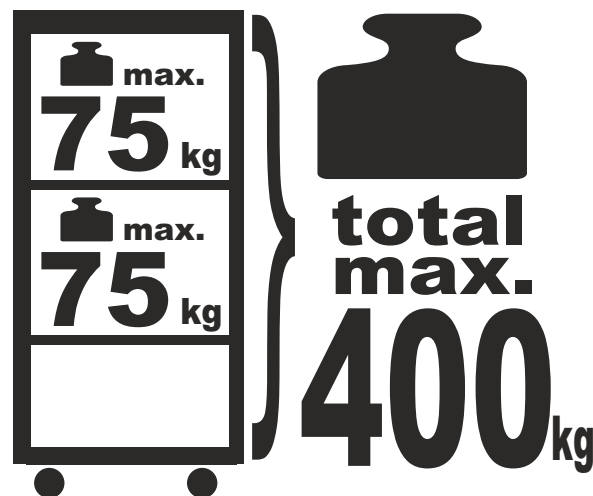
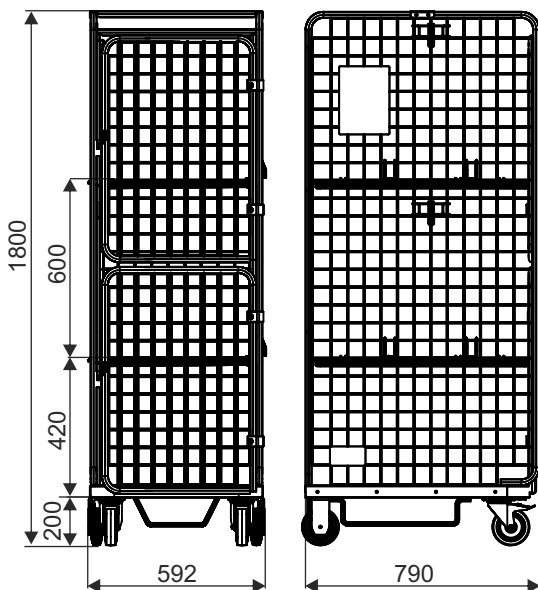

PRODUCT NAME	FINISH	INDEX
Container for logistic KLS-C 600x800x1800	zinc plated + lacquer	919-351-513

## **K** ROLLCONTAINERS

## CONTAINER 800X600 H1810 WITH BOTTOM FRAME „Z”

*basic version of the rollcontainer*



**Technical data:** structural stability is ensured by closed profiles, meshes made of steel bars, bottom with wheels (two fixed wheels, two swivel wheels), bottom shelf reinforced with flat bars. The construction enables container folding and nesting of folded containers. Standard version has chassis on wheels, two side walls and one shelf.

**Finish:** zinc + lacquer  
**Wheels:** diameter 125 mm  
**Nesting distance:** 270 mm  
**Shelf capacity:** 100 kg  
**Total capacity:** 500 kg

**Optional equipment:**

- rear wall,
- textile belts.

*Nesting of folded containers  
(top view):*

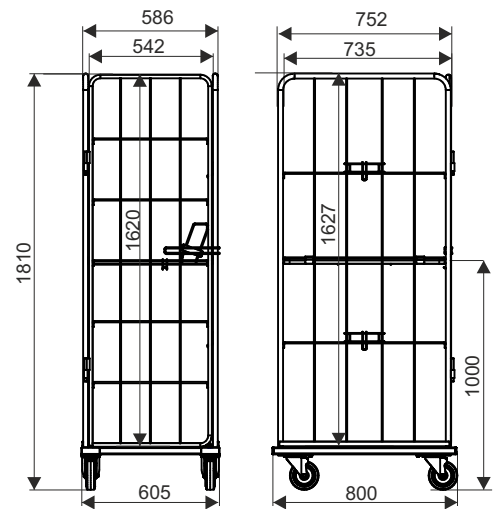
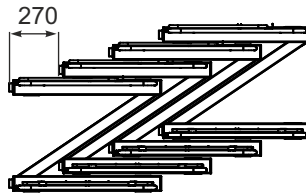

*version with full optional equipment*    *version with optional rear wall*



*Nesting of folded containers*

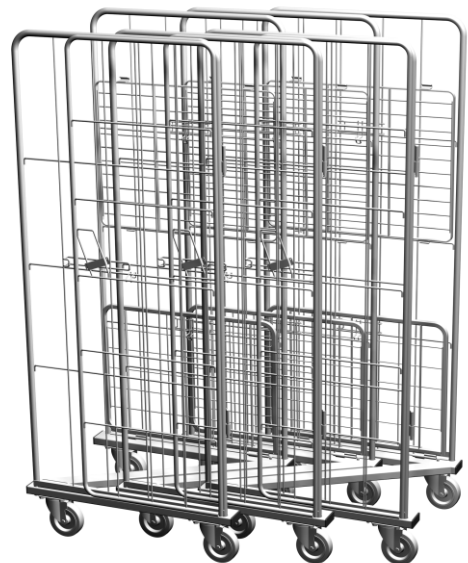

PRODUCT NAME	FINISH	INDEX
Container 800X600 H1810 with bottom frame „Z”	zinc plated + lacquer	919-351-416

### **K** ROLLCONTAINERS

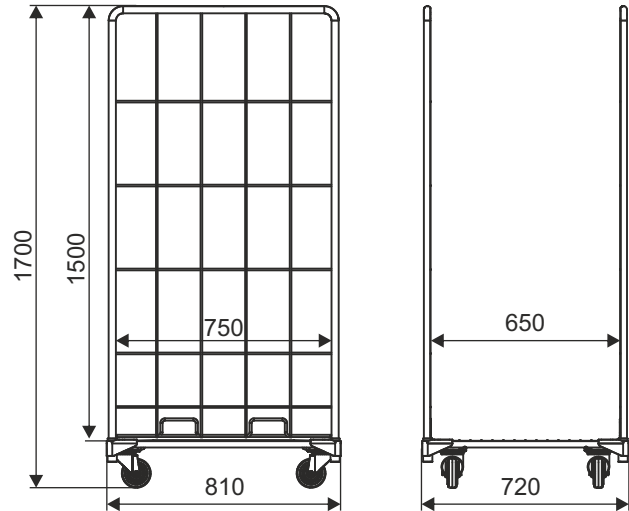

**Standard equipment**

- chassis on wheels
- side walls H-1700

**Total loading:** 500 kg

**Loading of the standard wire shelf:** 70 kg

**Loading of the reinforced wire shelf:** 100 kg

**Wheel:** polyamide 100 mm

**Standard finish:** zinc plated + lacquer

**Optional equipment**

- side wall H-1700, with identification board,
- side wall Securite H-1700,
- closed wall H-1700,
- bottom closed wall H-700,
- top closed wall H-700,
- standard wire shelf,
- reinforced wire shelf,
- corner bumpers,
- textile or rubber belt.

**POSSIBLE CONFIGURATIONS:**

*Container with side walls and belts*

*Container with securite side walls*

*Container with side walls, and closed wall H-1700*

*Container with side walls, and two closed walls H-1700*

*Container with side walls, and closed wall H-1700, with wire shelf*

*Container with side walls, closed wall H-1700, with top and bottom closed wall H-700*



PRODUCT NAME	FINISH	INDEX
Warehouse trolley 810x720 H1700	zinc plated + lacquer	919-351-470

**K ROLLCONTAINERS**

**Standard equipment:**

- chassis on wheels
- side walls H-1700



**Optional equipment:**

side wall H-1700, with identification board



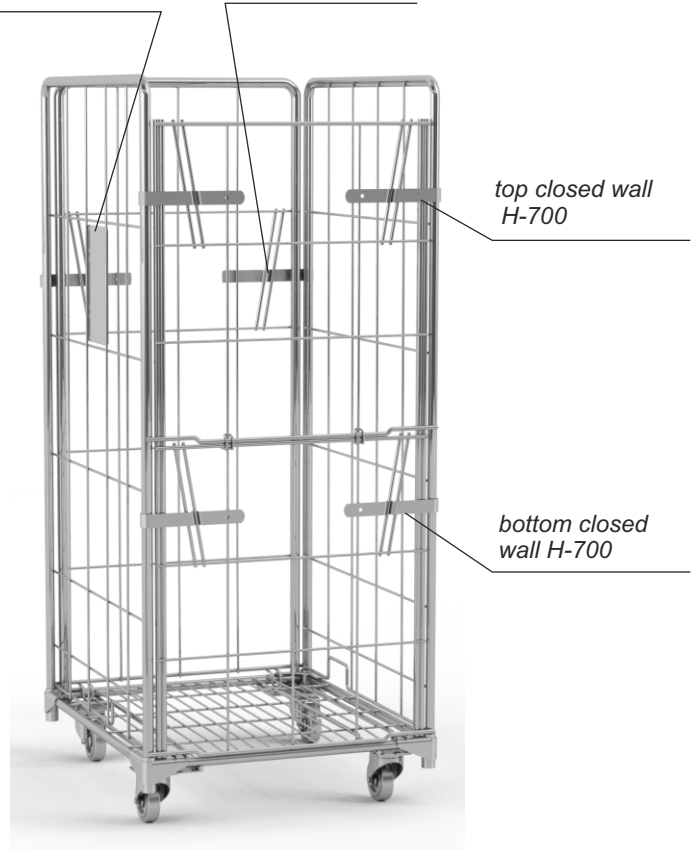

closed wall H-1700



top closed wall H-700

bottom closed wall H-700

**wheel types for container assembly:**

Wheel type	4 swivel wheels	4 swivel wheels, 2 wheels with the brakes	2 swivels wheels, 2 fixed wheels	2 swivel wheels with brake, 2 fixed wheels
 polypropylene Ø 100 mm	✓		✓	
 polyamide Ø 100 mm	✓	✓		✓
 polyamide Ø 125 mm	✓		✓	
 Rubber Ø 125 mm	✓	✓	✓	✓
 Sandwich Ø 125 mm			✓	✓

**standard wire shelf**

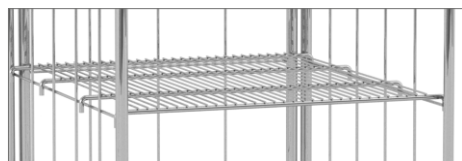

**reinforced wire shelf**



**textile or rubber belt**



**corner bumpers**



**side wall Securite**

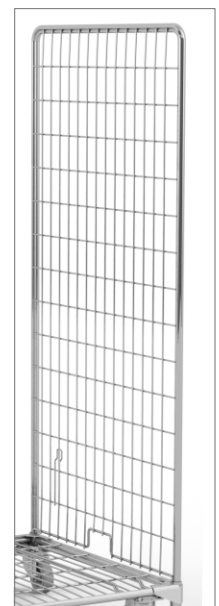

**K ROLLCONTAINERS**

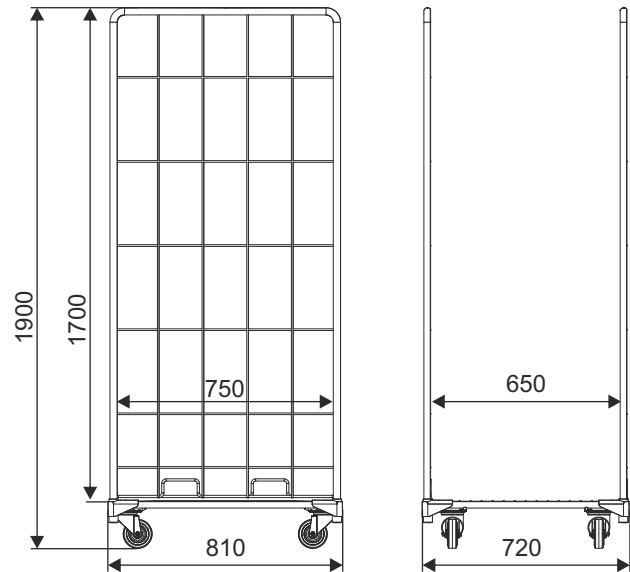
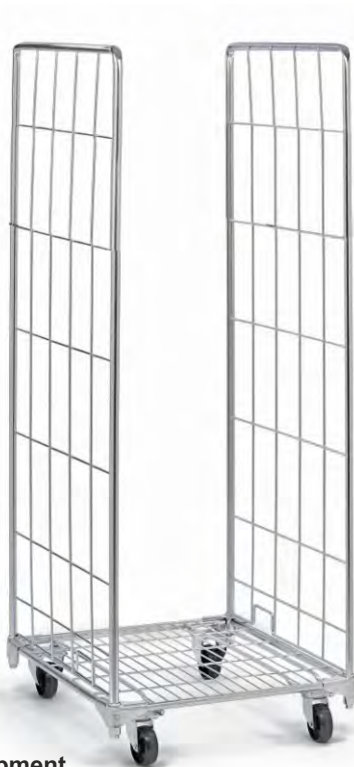
**Standard equipment**

- chassis on wheels
- side walls H-1900

**Total loading:** 500 kg

**Loading of the standard wire shelf:** 70 kg

**Loading of the reinforced wire shelf:** 100 kg

**Wheel:** polyamide 100 mm

**Standard finish:** zinc plated + lacquer

**Optional equipment**

- side wall H-1900, with identification board,
- side wall Securite H-1900,
- closed wall H-1900,
- bottom closed wall H-700,
- top closed wall H-700,
- standard wire shelf,
- reinforced wire shelf,
- corner bumpers,
- textile or rubber belt.

**POSSIBLE CONFIGURATIONS:**

*Container with side walls and belts*

*Container with securite side walls*

*Container with side walls, and closed wall H-1900*

*Container with side walls, and two closed walls H-1900*

*Container with side walls, and closed wall H-1900, with wire shelf*

*Container with side walls, closed wall H-1900, with top and bottom closed wall H-700*



PRODUCT NAME	FINISH	INDEX
Warehouse trolley 810x720 H1900	zinc plated + lacquer	919-351-470

**K ROLLCONTAINERS**

### Standard equipment:

- chassis on wheels
- side walls H-1900

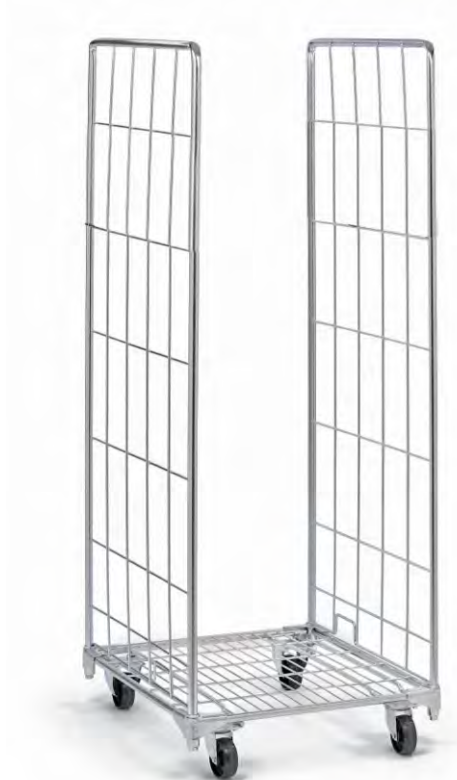

### Optional equipment:

side wall H-1900, with identification board



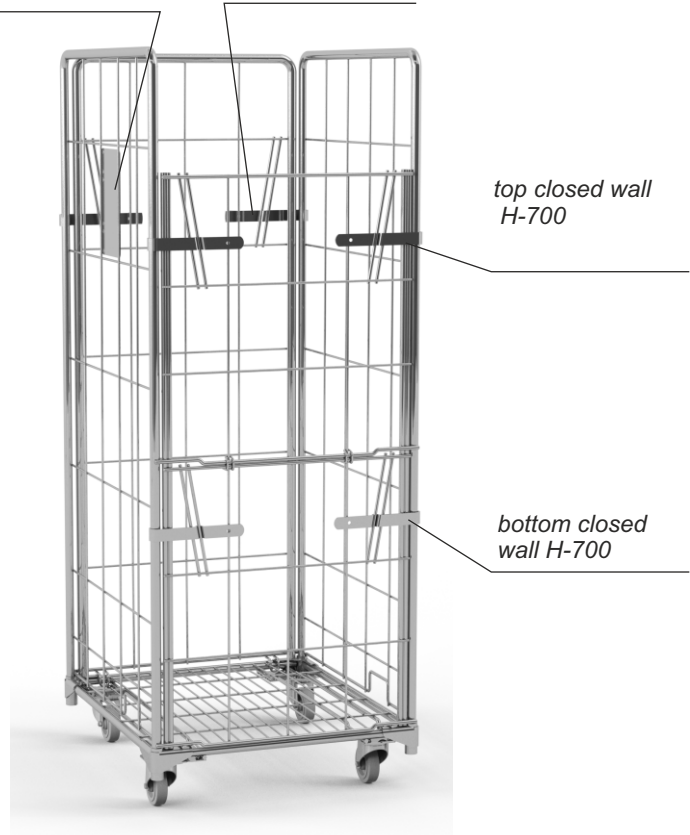

closed wall H-1900



top closed wall H-700

bottom closed wall H-700

### wheel types for container assembly:

Wheel type	4 swivel wheels	4 swivel wheels, 2 wheels with the brakes	2 swivels wheels, 2 fixed wheels	2 swivel wheels with brake, 2 fixed wheels
 polypropylene Ø 100 mm	✓		✓	
 polyamide Ø 100 mm	✓	✓		✓
 polyamide Ø 125 mm	✓		✓	
 Rubber Ø 125 mm	✓	✓	✓	✓
 Sandwich Ø 125 mm			✓	✓

standard wire shelf

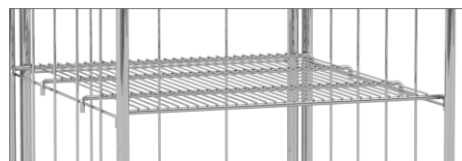

reinforced wire shelf



textile or rubber belt



corner bumpers



side wall Securite

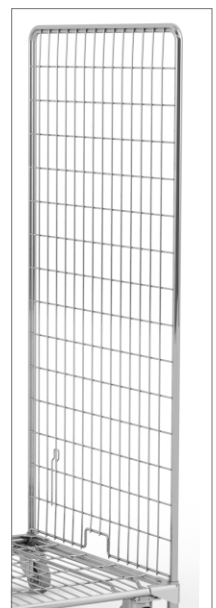

## **K** ROLLCONTAINERS

## CONTAINER FOR CARTONS 600x1000 H1200



*Unused containers can be folded at its mid-height and stacked one onto another:*



*Hinged hatches in the container:*



### Technical data:

The container made of wire and sections, the bottom is reinforced with flat iron, 2 hinged hatches, swivel wheels 125 mm – 4 pcs.

**Standard finish:** zinc plated + lacquer.

**Loading:** 200 kg

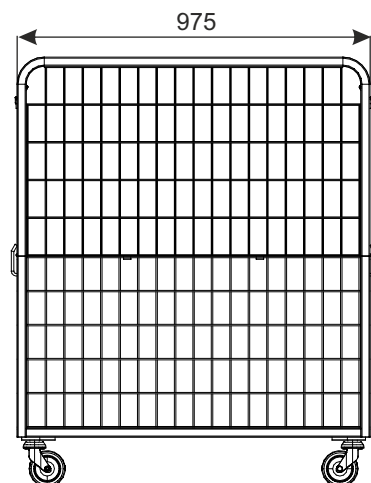
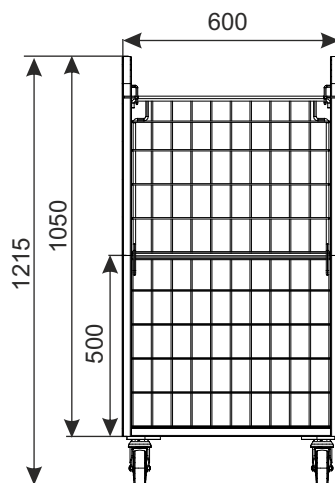

PRODUCT NAME	FINISH	INDEX
Container for cartons 600x1000 H1200	zinc plated + lacquer	919-351-238

### **K** ROLLCONTAINERS

## CONTAINER FOR CARTONS 800x1200 H1200



*Hinged hatches in the container:*



*Unused containers can be folded at its mid-height and stacked one onto another:*



**Technical data:**

The container made of wire and sections, the bottom is reinforced with flat iron, 2 hinged hatches, swivel wheels  $\varnothing$  125 mm – 4 pcs.

**Standard finish:** zinc plated + lacquer.

**Loading:** 200 kg

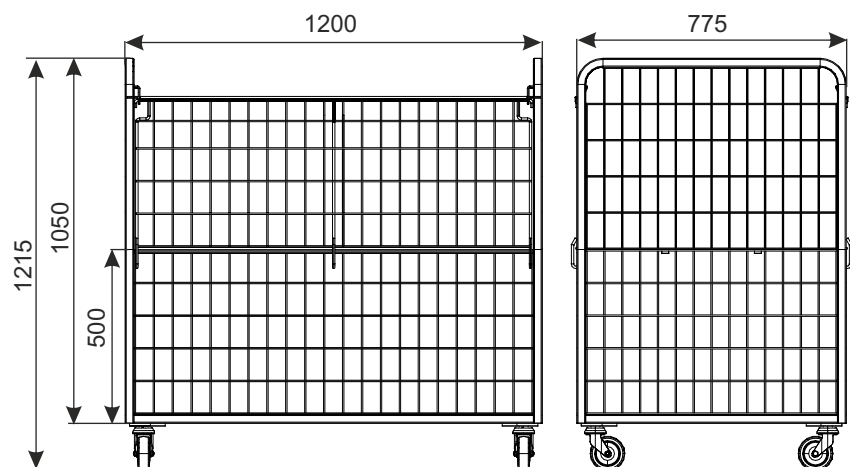

PRODUCT NAME	FINISH	INDEX
Container for cartons 800x1200 H1200	zinc plated + lacquer	919-351-237

**K ROLLCONTAINERS**

## CONTAINER KK-1015X800X600

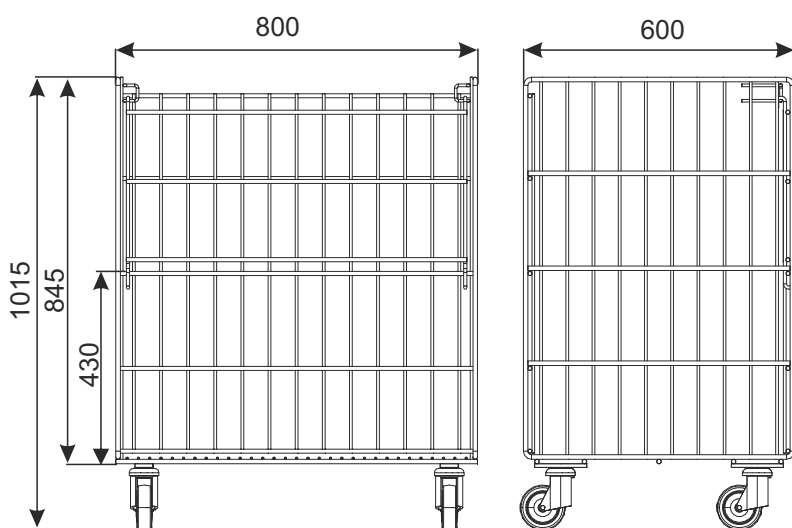

**Technical data:**  
 container made of wire, hinged hatch,  
 swivel wheels  $\varnothing 125$  mm - 4 pieces.  
**Standard finish:** zinc plated + lacquer.  
**Loading:** 200 kg

PRODUCT NAME	FINISH	INDEX
Container KK-1015x800x600	zinc plated + lacquer	919-351-158

### **K** ROLLCONTAINERS

## CONTAINER WITH 3 SHELVES 1100x600 H-1600



**Finish:** galvanic zinc + lacquer

**Technical data:** chassis of closed profiles (rectangular), shelves of sheet metal, reinforced from bottom. Wheels allow to movement of container. A possibility of regulation the shelves (at different heights).

Metal shelves lined with 3mm thick grooved rubber.

**Loading:**

- loading of shelf - 75 kg
- loading of base - 300 kg
- total loading - 525 kg

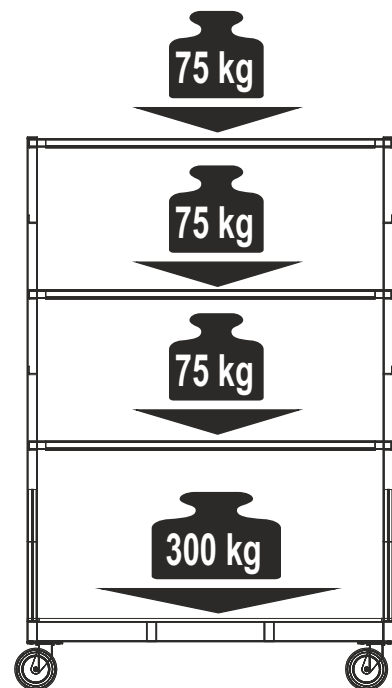
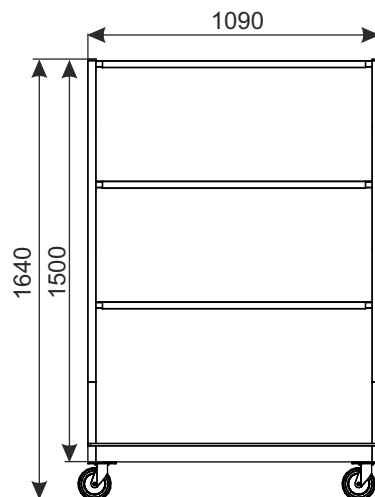
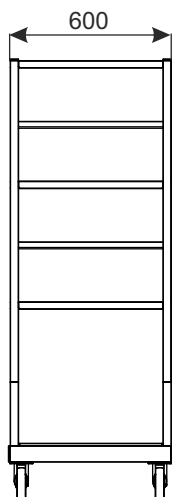

PRODUCT NAME	FINISH	INDEX
Container with 3 shelves 1100x600 H-1600	zinc plated + lacquer	919-351-018

### **K** ROLLCONTAINERS



## CONTAINER WITH 3 SHELVES 1100x750 H-1600



**Finish:** galvanic zinc + lacquer

**Technical data:** chassis of closed profiles (rectangular), shelves of sheet metal, reinforced from bottom. Wheels allow to movement of container. A possibility of regulation the shelves (at different heights). Metal shelves lined with 3mm thick grooved rubber.

**Loading:**

- loading of shelf - 75 kg
- loading of base - 300 kg
- total loading - 525 kg

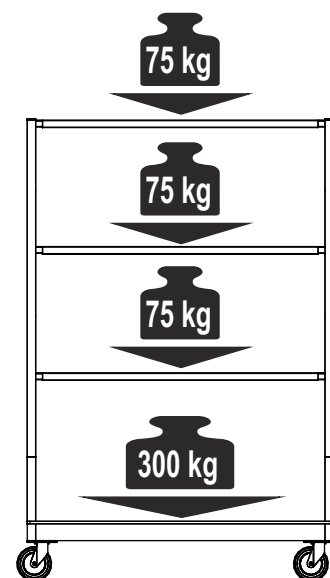
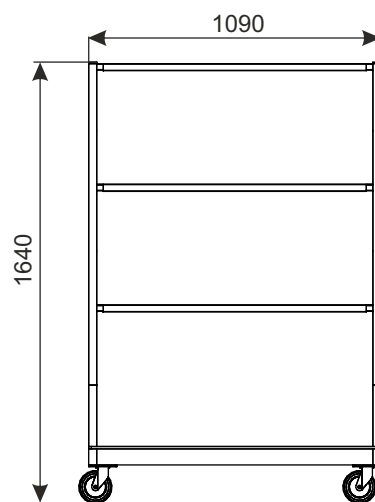
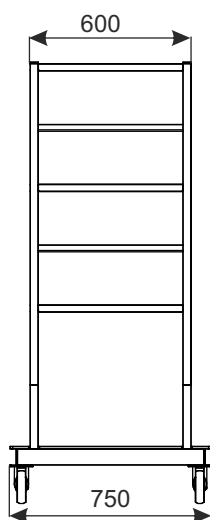

PRODUCT NAME	FINISH	INDEX
Container with 3 shelves 1100x750 H-1600	zinc plated + lacquer	919-343-751

### **K** ROLLCONTAINERS

## WAREHOUSE TROLLEY



Goods can be distributed on two levels; upper shelf can be foldable when it's not used.

**Loading:**  
total loading of trolley – 150 kg,  
loading of upper shelf – 50 kg

**Wheel:**  
Fixed, back wheels  $\varnothing 200$  mm and swivel front  $\varnothing 100$  mm  
allow optimal manoeuvrability.

**Coating:**  
zinc galvanized + lacquer.

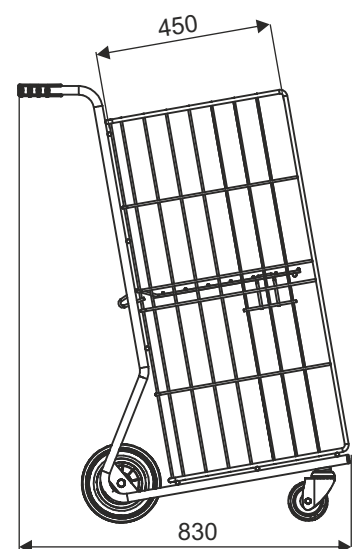
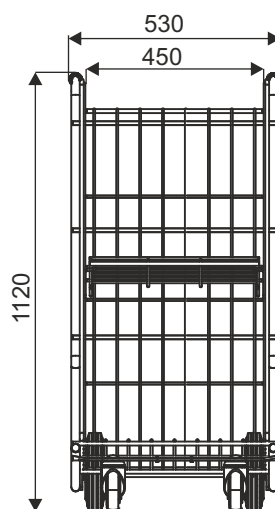

PRODUCT NAME	FINISH	INDEX
Warehouse trolley	zinc galvanized + lacquer	919-351-371

## K ROLLCONTAINERS

## WAREHOUSE TROLLEY WITH BASKET 800x600 H600 ON WHEELS



Trolley with a basket has been designed to facilitate the transport of products in warehouses etc.

Weight capacity up to 200kg. Swivel wheels  $\varnothing$  125mm ensure optimal manoeuvrability.

**Loading:** 200 kg

**Wheel diameter:** 125 mm

**Coating:** zinc galvanized + lacquer.

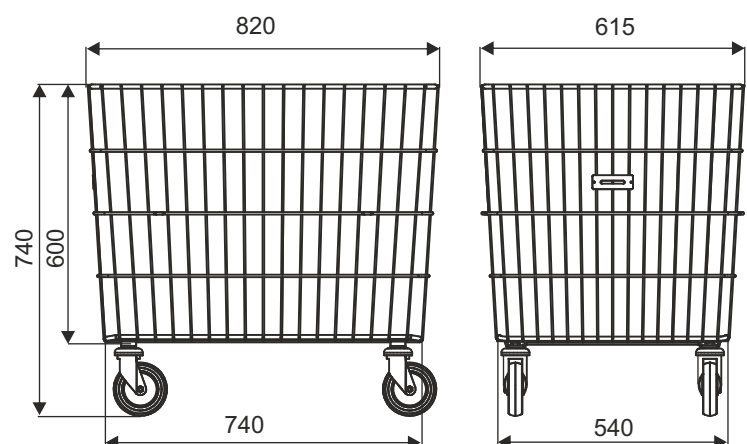

PRODUCT NAME	FINISH	INDEX
Warehouse trolley with basket 800x600 H600 on wheels	zinc galvanized + lacquer	919-351-382

### **K** ROLLCONTAINERS

## WAREHOUSE TROLLEY WITH BASKET 800x600 H600 WITH FRAME ON WHEELS



The basket of the trolley has been designed for easy loading/unloading. It's raised bottom allows the user to bend less and provide better access to the basket.

Trolley holds up to 200kg. Plastic cover of handle and swivel wheels  $\varnothing$  125 mm ensure easy handling and optimal manoeuvrability . Optional clipboard A4.

**Loading:** 200 kg

**Wheel diameter:** 125 mm

**Coating:** zinc galvanized + lacquer.

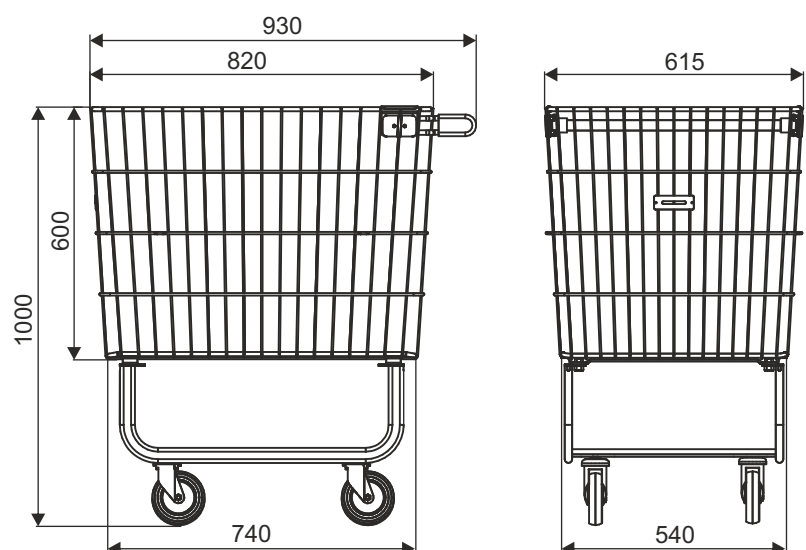

PRODUCT NAME	FINISH	INDEX
Warehouse trolley with basket 800x600 H600 with frame on wheels	zinc galvanized + lacquer	919-351-383

### **K** ROLLCONTAINERS

## STEEL MOBILE PALLET 600X400 MM



It's a perfect solution for carrying heavy goods such boxes, bins or furniture etc.

**Loading:** 200 kg.

**Wheel diameter:**

Swivel rubber wheels  $\varnothing$  80 ensure optimal manoeuvrability.

Option: wheels  $\varnothing$ 100mm.

**Coating:** zinc galvanized + lacquer.

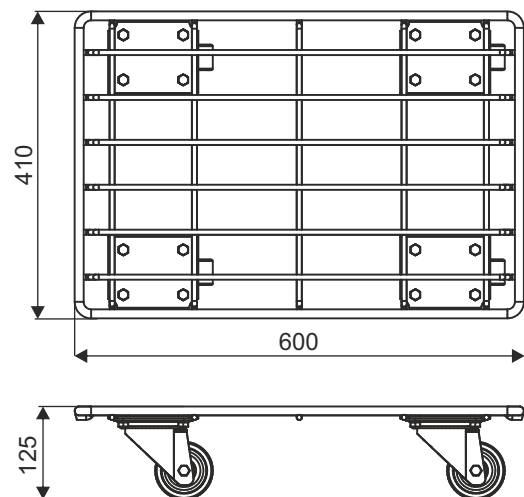

PRODUCT NAME	FINISH	INDEX
Steel mobile pallet 600x400 mm	zinc galvanized + lacquer	919-351-346

### **K** ROLLCONTAINERS

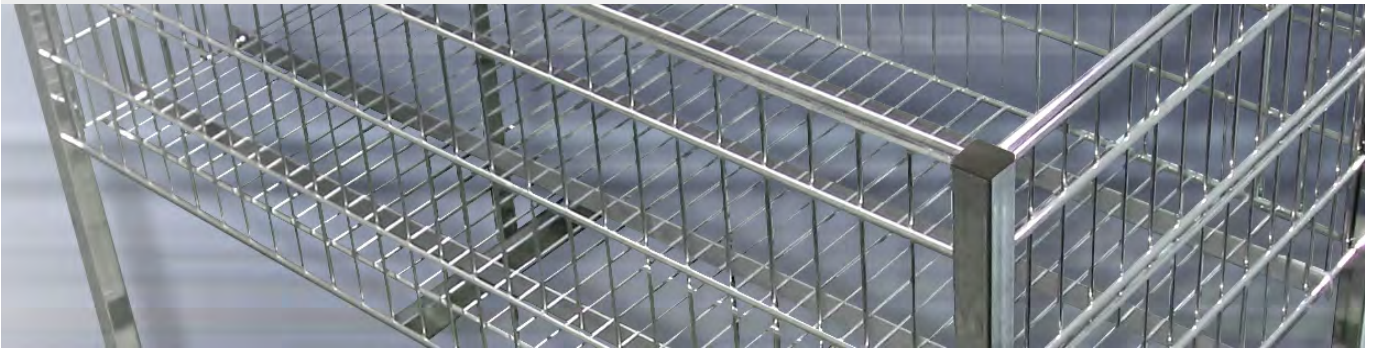

DISPLAY TABLES,  
DISPLAY TABLE EQUIPMENT,  
WIRE BASKETS

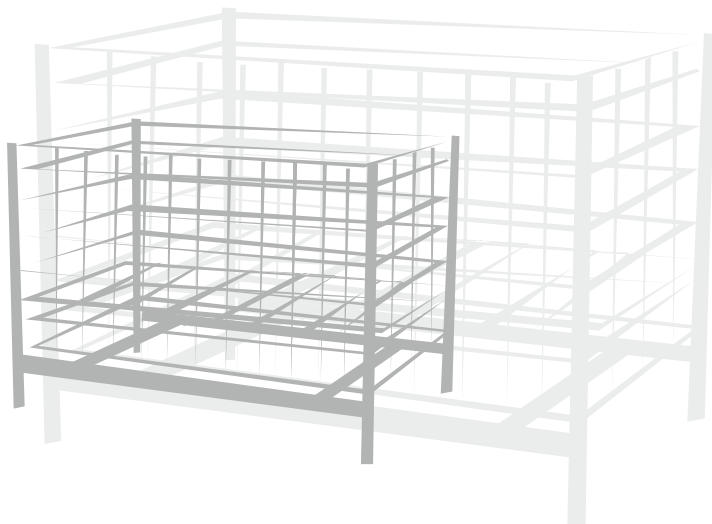

## **E1** DISPLAY TABLES, DISPLAY TABLE EQUIPMENT, WIRE BASKETS

- 1 Display table 1200x800 H-850/650
- 2 Display table 1200x800 H850/650 folded into horizontal position
- 3 Display table 1200x800 folded into vertical position
- 4 Display table 1200x800 folded into vertical position (powder coated)
- 5 Display table system P NON FOOD 1200x800 (with the closing flap)
- 6 Display table 1200x800 H-850/400
- 7 Display table 1200x600 H-850/650
- 8 Display table 1200x600 H-850/200
- 9 The bottom shelf to the display table 1200x600
- 10 Overhead attachment to the display table 1200x800 folded into vertical position
- 11 Overhead attachment 12x5 (1140x540) to the display table 1200
- 12 Overhead attachment 12x6 (1140x640) to the display table 1200
- 13 Divider H-270 to the display table 1200x800
- 14 Display table 600x600 H-850/400
- 15 The bottom shelf to the display table 600x600
- 16 Overhead attachment to the display table 600x600
- 17 Display table 800x600 H-850/650
- 18 Exposition grating 1200x600 to the display table
- 19 Dumping basket on legs
- 20 In-out Basket 615 x 650 x 860
- 21 Folding basket DSK16 (550x390x770)
- 22 Folding basket DSK18 (550x550x770)
- 23 Folding basket DSK 800x800 H780

*The reproduce without prior permission is forbidden. In order to improve, the manufacturer reserves the right to implement modifications in its products. Recommendations for installation and use the products are provided for informational purposes only and does not imply any liability on the part of the manufacturer.*

## **E1** DISPLAY TABLES, WIRE BASKETS

## DISPLAY TABLE 1200X800 H-850/650



### OPTIONAL EQUIPMENT:

An optional set of wheels mounted on the table makes it easy to move the table.



Display tables allow for presentation of small and unwieldy goods. The construction ensures that the display table is very stable and highly resistant to damages. The bottom reinforced with flat irons allows for exposition of goods with various sizes and weights. There is possibility of adjust the height of the bottom on two different levels at the same time. The table has additionally a divider. The construction allows for easy disassembly of the table. Divider and bottom split into two separate parts allow the exposure of different types of assortment at the same time.

**Standard finish:** zinc plated + lacquer or bright chrome. The bottom of the table is zinc plated + lacquer.

**Technical data:** Structure made of section, side meshes and the divider made of steel wire. Legs are screwed together with a lower frame and the side mesh panels are directly attached to the legs. Bottom made of steel wire is reinforced with flat iron and it consists of two parts.

**Maximum loading:** ca 200 kg (with equable spreading of the goods).

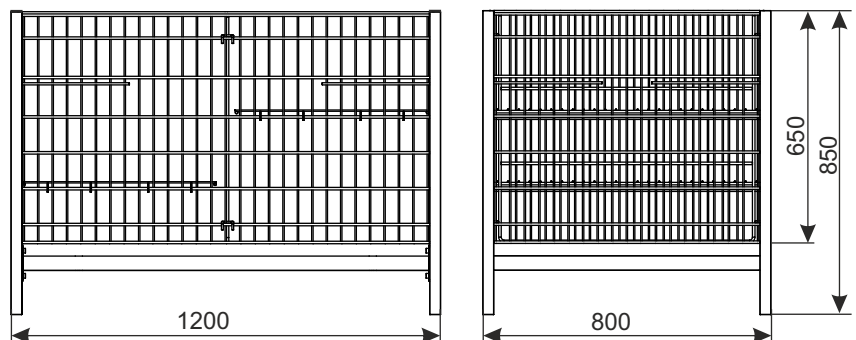

PRODUCT NAME	FINISH *	INDEX
Display table 1200x800 H-850/650*	zinc plated + lacquer	919-350-639
	bright chrome	919-320-436

\* The bottom of the table is zinc plated.

## E1 DISPLAY TABLES, WIRE BASKETS



## DISPLAY TABLE 1200X800 H850/650 FOLDED INTO HORIZONTAL POSITION

**NEW!**



Display tables allow for presentation of small and unwieldy goods. The construction ensures that the display table is very stable and highly resistant to damages. The bottom reinforced with flat irons allows for exposition of goods with various sizes and weights. There is possibility of adjust the height of the bottom on two different levels at the same time. Divider and bottom split into two separate parts allow the exposure of different types of assortment at the same time. The construction of the table allows for easy folding and unfolding. Unused tables can be quickly folded and stacked on top of each other, so they don't take up excessive warehouse space.

**Standard finish:** powder coated, optionally zinc plated + lacquer or bright chrome (the bottom - zinc plated + lacquer).

**Technical data:** Structure made of section, side meshes and the divider made of steel wire. Bottom made of steel wire is reinforced with flat iron and it consists of two parts. The frame, legs and sides are connected together with the possibility of convenient folding and unfolding the table.

**Maximum loading:** 150 kg (with equable spreading of the goods).

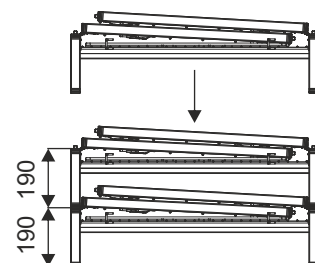
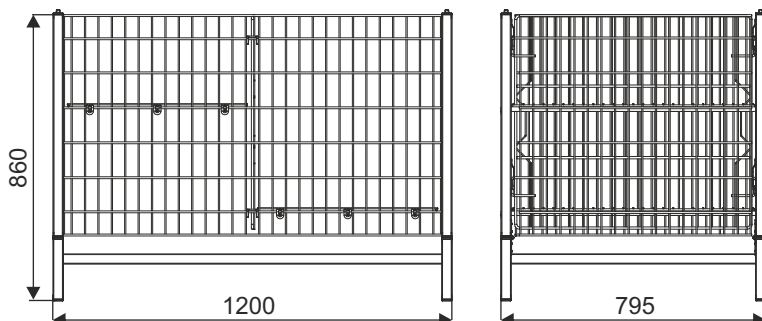

PRODUCT NAME	FINISH	INDEX
Display table 1200x800 H850/650 folded into horizontal position	powder coated	922-346-190
	zinc plated + lacquer* (option)	919-351-498
	bright chrome* (the bottom - zinc plated + lacquer) (option)	919-320-623

\* the bottom - zinc plated + lacquer

### **E1** DISPLAY TABLES, WIRE BASKETS

## DISPLAY TABLE 1200X800 FOLDED INTO VERTICAL POSITION



Display tables allow for presentation of small and unwieldy goods. The construction ensures that the display table is very stable and highly resistant to damages. The bottom reinforced with flat irons allows for exposition of goods with various sizes and weights. There is a possibility of adjusting the height of the bottom on two different levels at the same time. Divider and bottom split into two separate parts allow the exposure of different types of assortment at the same time. The construction of the table allows for easy folding and unfolding. Unused table folded into a vertical position doesn't take up excessive warehouse space.

**Standard finish:** zinc plated + lacquer or bright chrome. The bottom of the table is zinc plated + lacquer.

**Technical data:** Structure made of section, side meshes and the divider made of steel wire. Bottom made of steel wire is reinforced with flat iron and it consists of two parts. The frame, legs and sides are connected together with the possibility of convenient folding and unfolding the table.

**Maximum loading:** 150 kg (with equable spreading of the goods).

### OPTIONAL EQUIPMENT:

An optional set of wheels mounted on the table makes it easy to move the table.

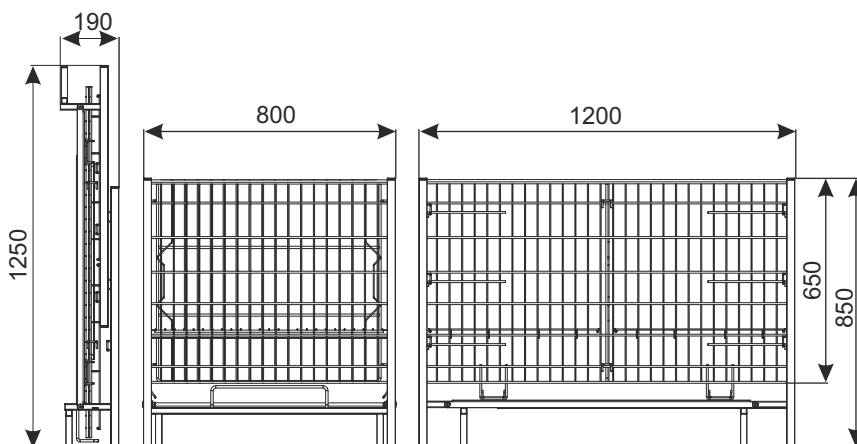

PRODUCT NAME	FINISH*	INDEX
Display table 1200x800 folded into vertical position	zinc plated + lacquer	919-320-577
	bright chrome**	

\* The bottom of the table is zinc plated.

## E1 DISPLAY TABLES, WIRE BASKETS

## DISPLAY TABLE 1200X800 FOLDED INTO VERTICAL POSITION (powder coated)

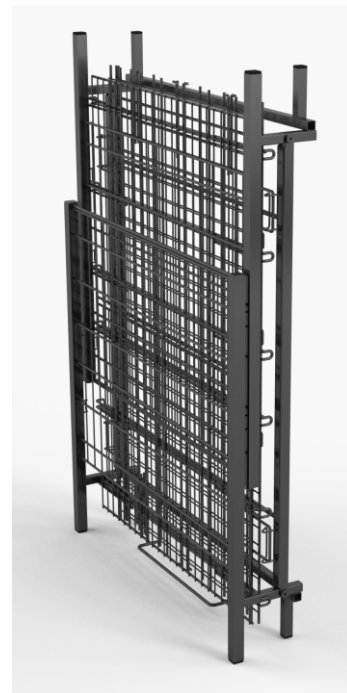

The table allows for presentation and sale goods. The construction of the table allows for easy folding and unfolding. Unused table folded into a vertical position doesn't take up excessive warehouse space.

### Technical data:

The table made of section, side meshes and the divider made of steel wire. Bottom made of steel wire is reinforced with flat iron and it consists of two parts. There is possibility of adjust the height of the bottom on two different levels at the same time. The frame, legs and sides are connected together with the possibility of convenient folding and unfolding the table.

**Maximum loading:** 150 kg



*Shelf with wire hooks, strengthened with flat bars*

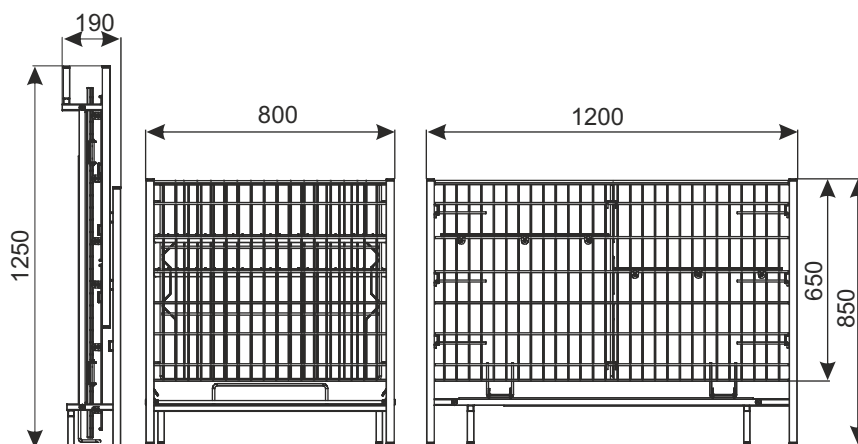

*Wire hooks of the shelf*



PRODUCT NAME	FINISH	INDEX
Display table 1200x800 folded into vertical position (powder coated)	powder coated RAL 7016	919-320-577_V2

## E1 DISPLAY TABLES, WIRE BASKETS

## DISPLAY TABLE SYSTEM P NON FOOD 1200X800 (with the closing flap)



Display tables allows for presentation of small and unwieldy goods.

The construction ensures that the display table is very stable and highly resistant to damages. The bottom reinforced with flat irons allows for exposition of goods with various sizes and weights. There is possibility of adjust the height of the bottom on two different levels at the same time. The table has additionally a divider. The construction allows for easy disassembly of the table. Divider and bottom split into two separate parts allow the exposure of different types of assortment at the same time.

One of the long sides of the table is equipped with the closing flap to simplify access to exposed products.

**Standard finish:** zinc plated + lacquer or bright chrome. The bottom of the table is zinc plated + lacquer.

**Technical data:** Structure made of section, side meshes and the divider made of steel wire. Legs are screwed together with a lower frame and the side mesh panels are directly attached to the legs. Bottom made of steel wire is reinforced with flat iron and it consists of two parts.

**Maximum loading:** ca 200 kg (with equable spreading of the goods).

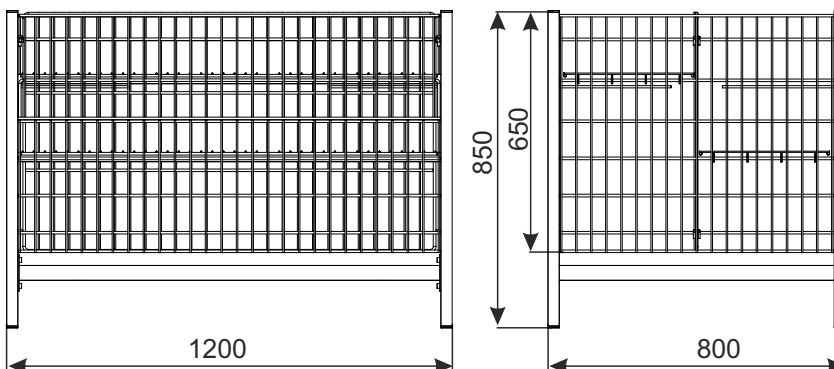

PRODUCT NAME	FINISH	INDEX
Display table System P Non Food 1200x800 (with the closing flap)	zinc plated + lacquer	—
Display table System P Non Food 1200x800 (with the closing flap)*	bright chrome	919-320-571

\*The bottom of the table is zinc plated.

### E1 DISPLAY TABLES, WIRE BASKETS

## DISPLAY TABLE 1200X800 H-850/400



Display tables allow for presentation of small and unwieldy goods. The construction ensures that the display table is very stable and highly resistant to damages. The bottom reinforced with flat irons allows for exposition of goods with various sizes and weights. There is possibility of adjust the height of the bottom. The construction allows for easy disassembly of the table.

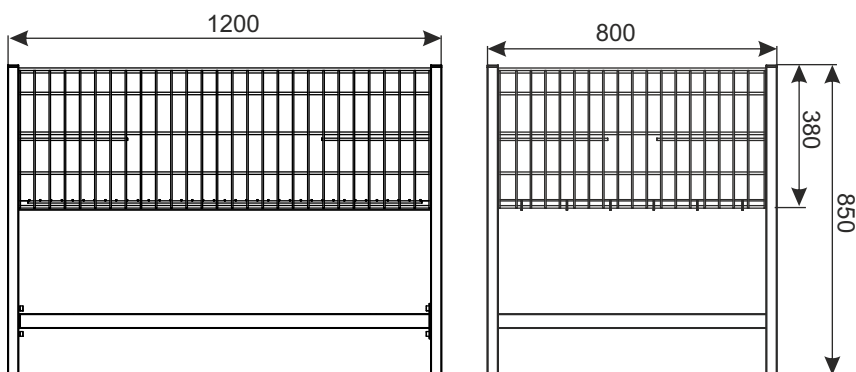

**Standard finish:** zinc plated + lacquer or bright chrome. The bottom of the table is zinc plated + lacquer.

**Technical data:** Structure made of section, side meshes made of steel wire. Legs are screwed together with a lower frame and the side mesh panels are directly attached to the legs. Bottom made of steel wire is reinforced with flat iron.

**Maximum loading:** ca 200 kg (with equable spreading of the goods).

PRODUCT NAME	FINISH*	INDEX
Display table 1200x800 H-850/400	zinc plated + lacquer	919-350-287
Display table 1200x800 H-850/400*	bright chrome	—

\*The bottom of the table is zinc plated.

### E1 DISPLAY TABLES, WIRE BASKETS

## DISPLAY TABLE 1200X600 H-850/650



Display tables allow for presentation of small and unwieldy goods. The construction ensures that the display table is very stable and highly resistant to damages. The bottom reinforced with flat irons allows for exposition of goods with various sizes and weights. There is possibility of adjust the height of the bottom on two different levels at the same time. The table has additionally a divider. The construction allows for easy disassembly of the table. Divider and bottom split into two separate parts allow the exposure of different types of assortment at the same time.

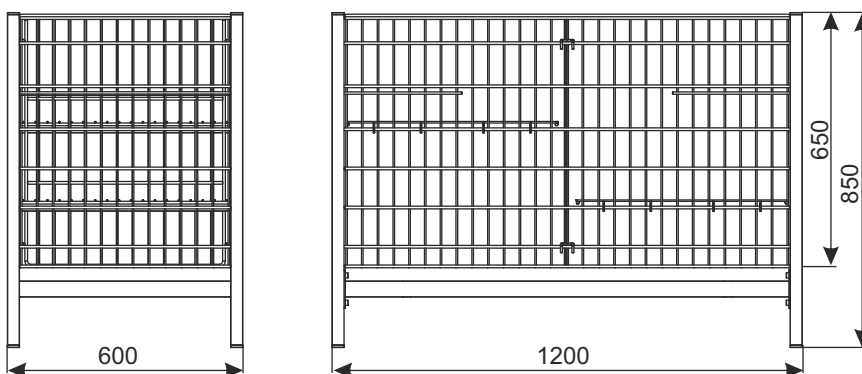

**Standard finish:** zinc plated + lacquer or bright chrome. The bottom of the table is zinc plated + lacquer.

**Technical data:** Structure made of section, side meshes and the divider made of steel wire. Legs are screwed together with a lower frame and the side mesh panels are directly attached to the legs. Bottom made of steel wire is reinforced with flat iron and it consists of two parts.

**Maximum loading:** ca 150 kg (with equable spreading of the goods).

PRODUCT NAME	FINISH *	INDEX
Display table 1200x600 H-850/650*	bright chrome	919-320-530
Display table 1200x600 H-850/650	zinc plated + lacquer	—

\* The bottom of the table is zinc plated.

### E1 DISPLAY TABLES, WIRE BASKETS

## DISPLAY TABLE 1200X600 H-850/200



Display tables allows for presentation of small and unwieldy goods. The construction ensures that the display table is very stable and highly resistant to damages. The bottom reinforced with flat irons allows for exposition of goods with various sizes and weights. There is possibility of adjust the height of the bottom. The construction allows for easy disassembly of the table.

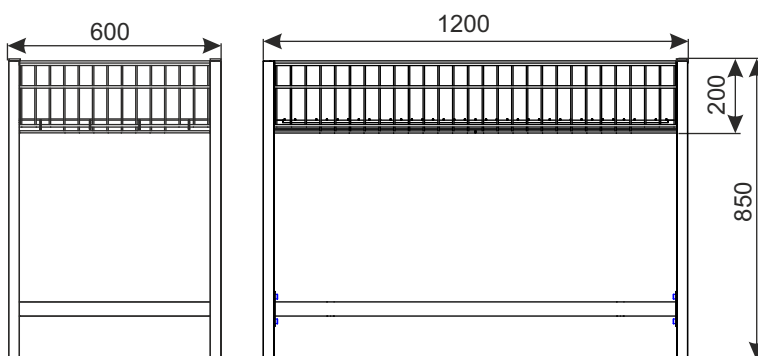

**Standard finish:** zinc plated + lacquer or bright chrome. The bottom of the table is zinc plated +lacquer.

**Technical data:** Structure made of section, side meshes made of steel wire. Legs are screwed together with a lower frame and the side mesh panels are directly attached to the legs. Bottom made of steel wire is reinforced with flat iron.

**Maximum loading:** ca 150 kg (with equable spreading of the goods).

PRODUCT NAME	FINISH *	INDEX
Display table 1200x600 H-850/200*	bright chrome	919-320-448-V2
Display table 1200x600 H-850/200	zinc plated + lacquer	—

\* The bottom of the table is zinc plated.

### E1 DISPLAY TABLES, WIRE BASKETS

## THE BOTTOM SHELF TO THE DISPLAY TABLE 1200X600

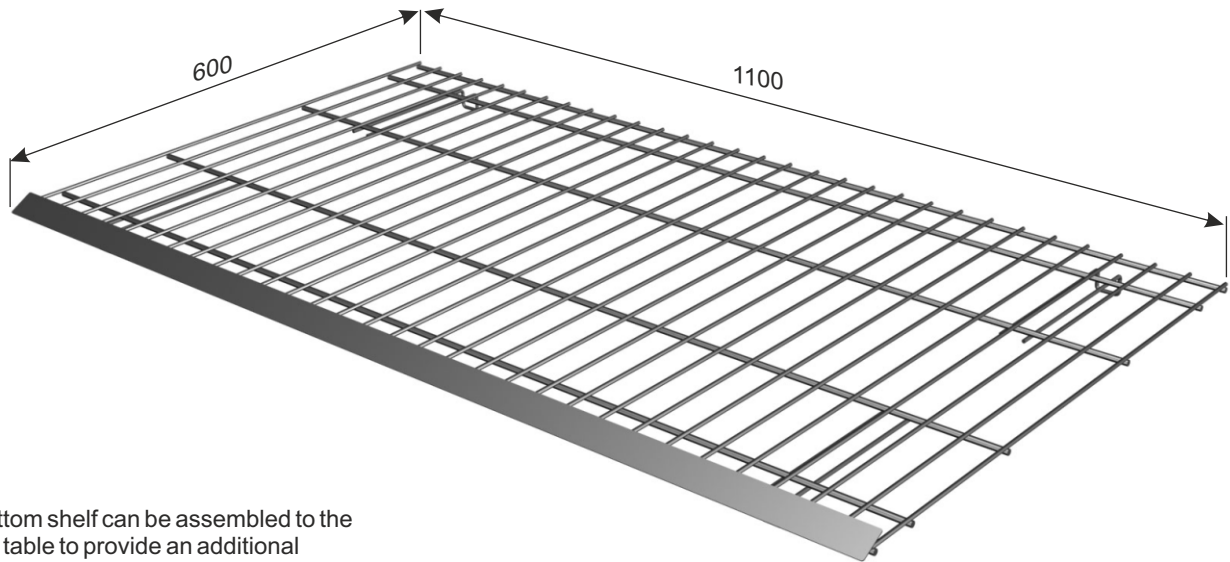

The bottom shelf can be assembled to the display table to provide an additional surface to sell or storage goods. It can be assemble to the table base. There is a price strip on the one side of the shelf.

**Standard finish:** zinc plated + lacquer or bright chrome.  
**Technical data:** shelf made of wire, in front of the table there is a clamping, made of metal plate, to the price strip.  
**Maximum loading:** ca 25 kg (with equable spreading of the goods).



The bottom shelf belongs to the additional equipment and it's adapted to assembly to display table 1200x600.

PRODUCT NAME	FINISH	INDEX
The bottom shelf to the display table 1200x600	zinc plated + lacquer	919-350-805
The bottom shelf to the display table 1200x600	bright chrome	—

### E1 DISPLAY TABLES, WIRE BASKETS



## OVERHEAD ATTACHMENT TO THE DISPLAY TABLE 1200X800 FOLDED INTO VERTICAL POSITION



### Optional equipment:

- Adapter to overhead attachment - allows that overhead attachment for mounting on a 1200x800 vertically folding table can be mounted on other display tables (with legs from section 30x30x2 mm and 30x30x1,5).

### -The possibilities of mounting:

- Overhead attachment can be mounted directly on display table with legs from section 25x25x1,5 mm (display table 1200x800 folded into vertical position).  
 - Adapter to overhead attachment 30x30x2 allows assembly of overhead attachment on display table with legs from section 30x30x2.  
 - Adapter to overhead attachment 30x30x1,5 allows assembly of overhead attachment on display table with legs from section 30x30x1,5.

An overhead attachment is a simple and reliable means for displaying lightweight products with small dimensions. Easy assembly with the display table makes it possible to show a greater quantity of products, creating additional sales areas.

**Standard finish:** zinc plated + lacquer or bright chrome.

**Technical data:** The frame of overhead attachment is made from section, stuck in the display table legs (after removing plugs from the display table). The shelf of overhead attachment is made from wire, reinforced with flat bars, fixed on brackets which are stuck in the perforation of the frame of overhead attachment. Side walls are fixed in bracket with the possibility of folding. There is a possibility of mounting price strip at the front of shelf.

**Maximum loading:** 75 kg (with equable spreading of the goods).

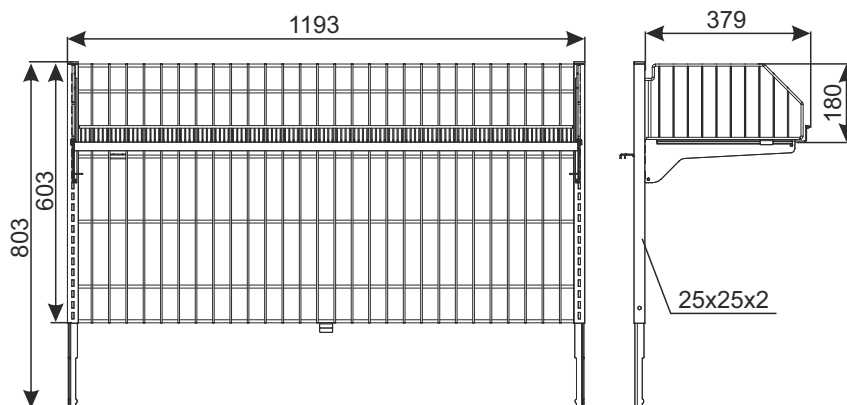

### Assembly with adapter:

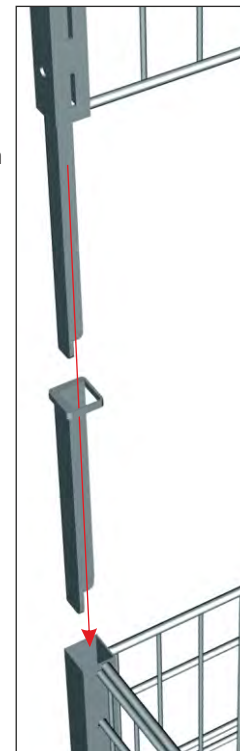

### Types of adapters:

Adapter to overhead attachment from section 30x30x2

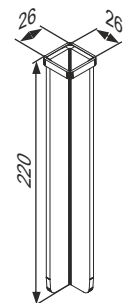

Adapter to overhead attachment from section 30x30x1,5

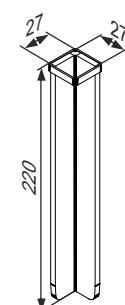

PRODUCT NAME	FINISH	INDEX
Overhead attachment to the display table 1200x800 folded into vertical position	zinc plated + lacquer	—
Overhead attachment to the display table 1200x800 folded into vertical position	bright chrome*	919-320-615
Overhead attachment to the display table 1200x800 folded into vertical position	powder coated RAL 7016	919-320-615_V2
Adapter to overhead attachment 30x30x2 (option)	zinc plated	—
Adapter to overhead attachment 30x30x1,5 (option)	zinc plated	—

## E1 DISPLAY TABLES, WIRE BASKETS

## OVERHEAD ATTACHMENT 12x5 (1140x540) TO THE DISPLAY TABLE 1200



An overhead attachment is a simple and reliable means for displaying lightweight products with small dimensions. Easy assembly with the display table makes it possible to show a greater quantity of products, creating additional sales areas.

Overhead Attachment is mounted directly on the table 1200

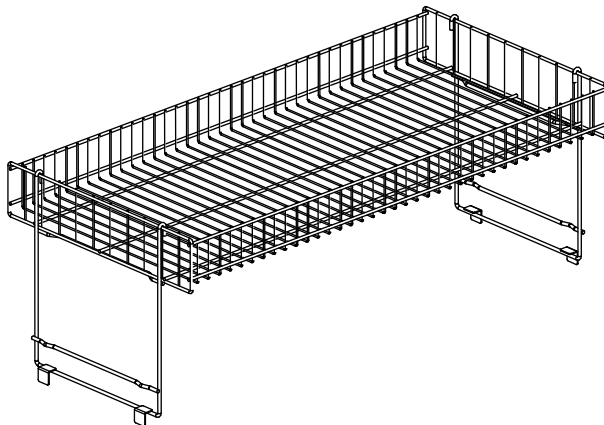

**Standard finish:** zinc plated + lacquer or bright chrome.

**Technical data:** basket and holders made of wire.

**Maximum loading:** ca 20 kg (with equable spreading of the goods).

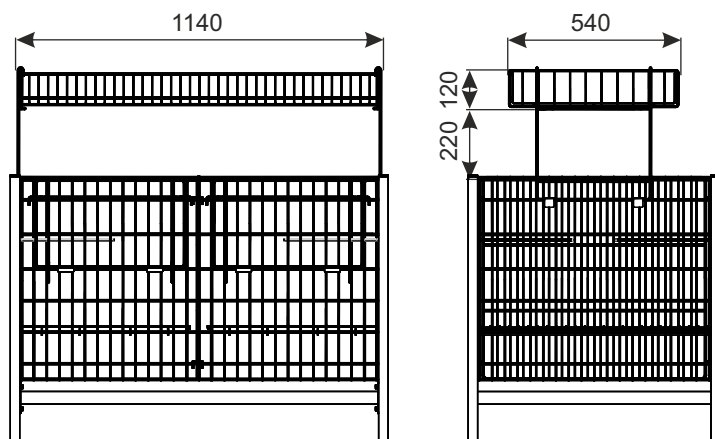

PRODUCT NAME	FINISH	INDEX
Overhead attachment 12x5 (1140x540) to the display table 1200	bright chrome	919-320-535
Overhead attachment 12x5 (1140x540) to the display table 1200	zinc plated + lacquer	919-350-821

### E1 DISPLAY TABLES, WIRE BASKETS

## OVERHEAD ATTACHMENT 12X6 (1140X640) TO THE DISPLAY TABLE 1200



An overhead attachment is a simple and reliable means for displaying lightweight products with small dimensions. Easy assembly with the display table makes it possible to show a greater quantity of products, creating additional sales areas.

Overhead Attachment is mounted directly on the table 1200

**Standard finish:** zinc plated + lacquer or bright chrome.

**Technical data:** basket and holders made of wire.

**Maximum loading:** ca 20 kg (with equable spreading of the goods).

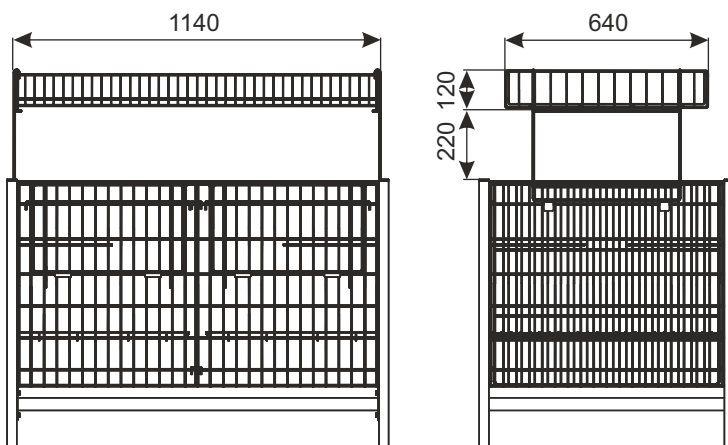
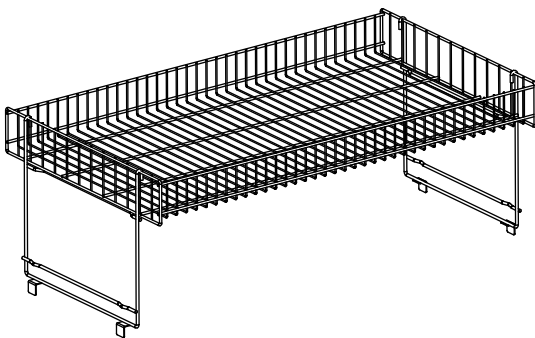

PRODUCT NAME	FINISH	INDEX
Overhead attachment 12x6 (1140x640) to the display table 1200	bright chrome	_____
Overhead attachment 12x6 (1140x640) to the display table 1200	zinc plated + lacquer	919-350-941

### E1 DISPLAY TABLES, WIRE BASKETS

## DIVIDER H-270 TO THE DISPLAY TABLE 1200X800

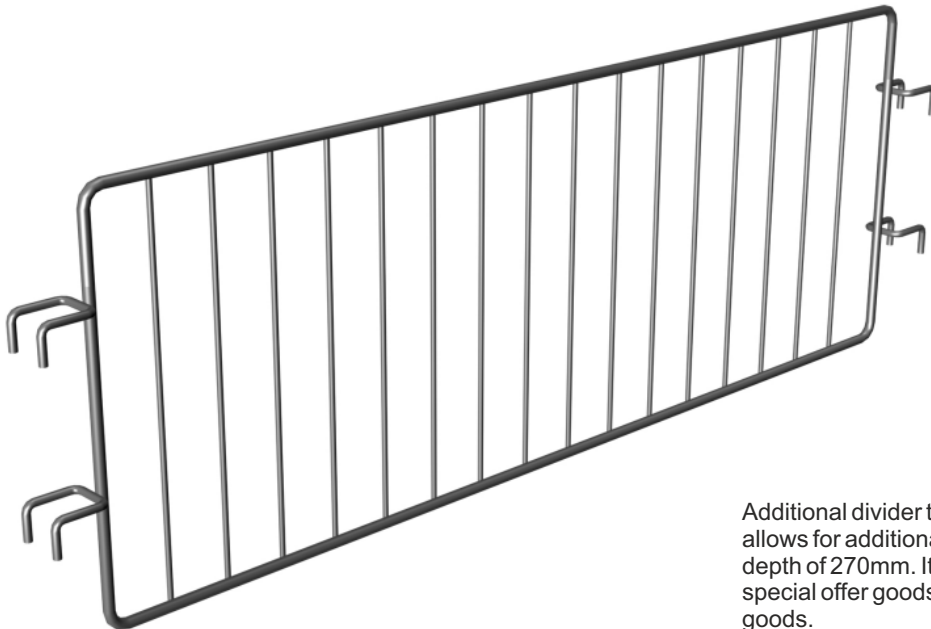

Additional divider to display table is used optionally and allows for additional separation of the another section with depth of 270mm. It enables to create more small sections for special offer goods or exposition of small and unwieldy goods.

The divider belongs to the additional equipment and it's adapted to assembly on the display table 1200x800 with walls H-400 and H-650.

**Standard finish:** zinc plated + lacquer or bright chrome.

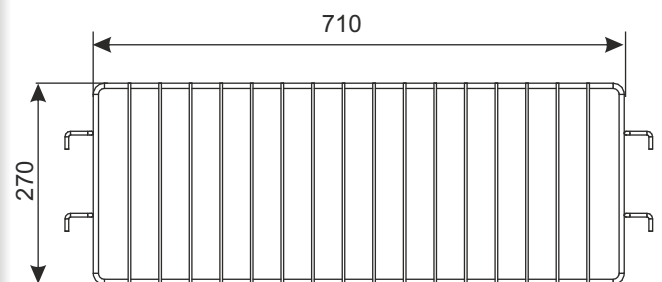
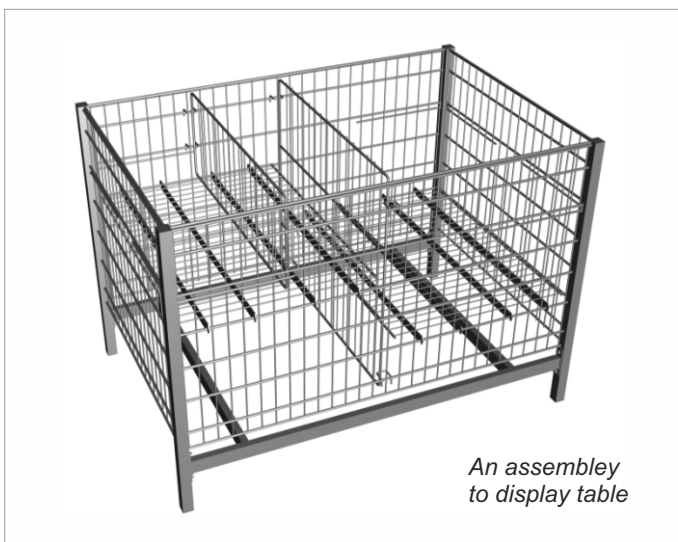

PRODUCT NAME	FINISH	INDEX
Divider H-270 to the display table 1200x800	bright chrome	919-320-487
	zinc plated + lacquer	919-350-822

### E1 DISPLAY TABLES, WIRE BASKETS

## DISPLAY TABLE 600X600 H-850/400



Display tables allows for presentation of small and unwieldy goods. The construction ensures that the display table is very stable and highly resistant to damages. The bottom reinforced with flat irons allows for exposition of goods with various sizes and weights. There is possibility of adjust the height of the bottom. The construction allows for easy disassembly of the table.

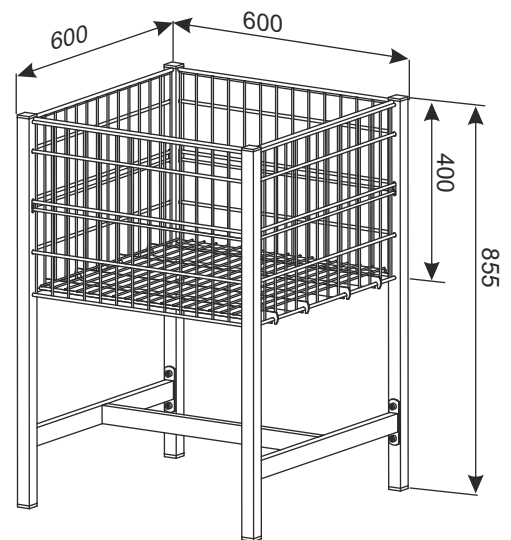

**Standard finish:** zinc plated + lacquer or bright chrome.

The bottom of the table is zinc plated + lacquer.

**Technical data:** Structure made of section, side meshes made of steel wire. Legs are screwed together with a lower frame and the side mesh panels are directly attached to the legs. Bottom made of steel wire is reinforced with flat iron.

**Maximum loading:** ca 100 kg (with equable spreading of the goods).

PRODUCT NAME	FINISH*	INDEX
Display table 600x600 H-850/400*	bright chrome	919-320-532
Display table 600x600 H-850/400	zinc plated + lacquer	919-351-069

\* The bottom of the table is zinc plated.

### E1 DISPLAY TABLES, WIRE BASKETS

## THE BOTTOM SHELF TO THE DISPLAY TABLE 600X600

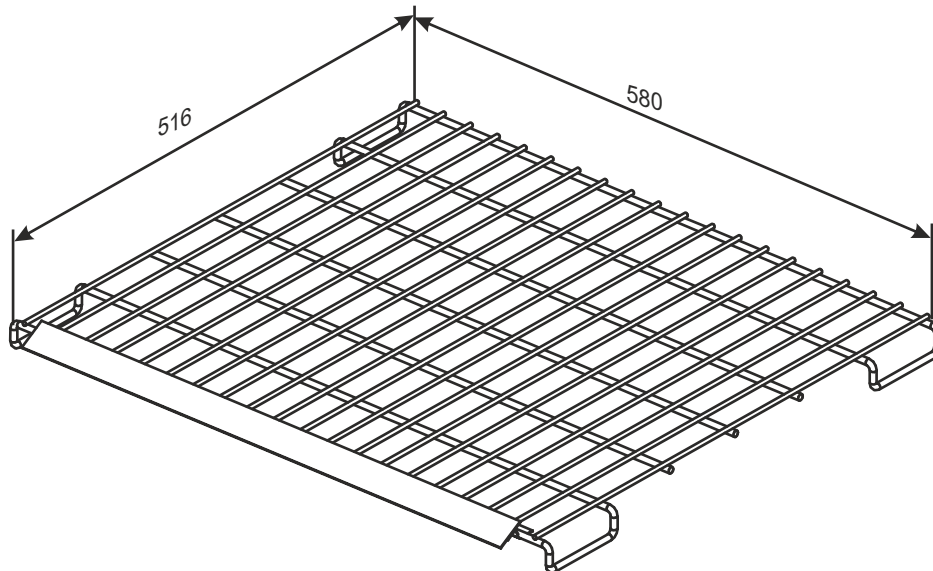

The bottom shelf can be assembled to the display table to provide an additional surface to sell or storage goods. It can be assemble to the table base. There is a price strip on the one side of the shelf.

**Standard finish:** zinc plated + lacquer or bright chrome.

**Technical data:** shelf made of wire, in front of the table there is a clamping, made of metal plate, to the price strip.

**Maximum loading:** ca 25 kg (with equable spreading of the goods).



The bottom shelf belongs to the additional equipment and it's adapted to assembly to display table 600x600.

PRODUCT NAME	FINISH	INDEX
The bottom shelf to the display table 600x600	bright chrome	919-320-534
The bottom shelf to the display table 600x600	zinc plated + lacquer	—

### E1 DISPLAY TABLES, WIRE BASKETS

## OVERHEAD ATTACHMENT TO THE DISPLAY TABLE 600X600



**Standard finish:** zinc plated + lacquer or bright chrome.  
**Technical data:** basket and holders made of wire.  
**Maximum loading:** ca 20 kg (with equable spreading of the goods).

An overhead attachment is a simple and reliable means for displaying lightweight products with small dimensions. Easy assembly with the display table makes it possible to show a greater quantity of products, creating additional sales areas. Overhead Attachment is mounted directly on the table 600x600.

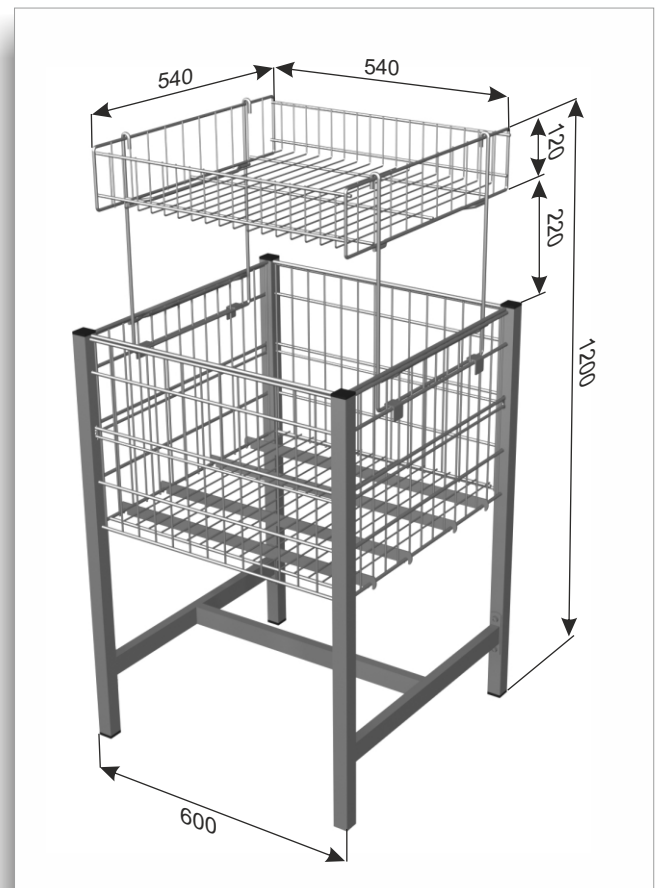

PRODUCT NAME	FINISH	INDEX
Overhead attachment to the display table 600x600	bright chrome	919-320-533
Overhead attachment to the display table 600x600	zinc plated + lacquer	—

### E1 DISPLAY TABLES, WIRE BASKETS

## DISPLAY TABLE 800X600 H-850/650



Display tables allows for presentation of small and unwieldy goods. The construction ensures that the display table is very stable and highly resistant to damages. The bottom reinforced with flat irons allows for exposition of goods with various sizes and weights. There is possibility of adjust the height of the bottom. The construction allows for easy disassembly of the table.

**Standard finish:** zinc plated + lacquer or bright chrome. The bottom of the table is zinc plated + lacquer.

**Technical data:** Structure made of section, side meshes made of steel wire. Legs are screwed together with a lower frame and the side mesh panels are directly attached to the legs. Bottom made of steel wire is reinforced with flat iron.

**Maximum loading:** ca 100 kg (with equable spreading of the goods).

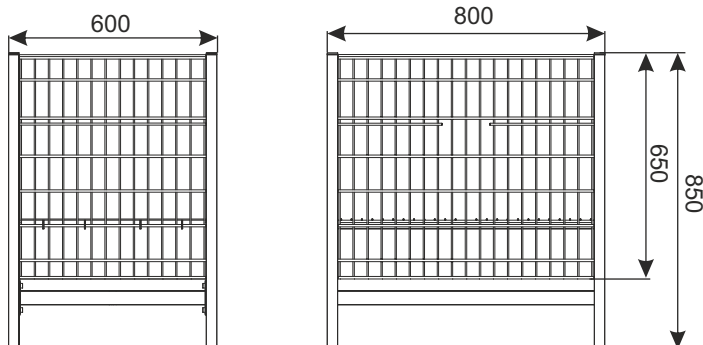

PRODUCT NAME	FINISH *	INDEX
Display table 800x600 H-850/650*	bright chrome	_____
Display table 800x600 H-850/650	zinc plated + lacquer	919-350-919

\* The bottom of the table is zinc plated.

### E1 DISPLAY TABLES, WIRE BASKETS



## EXPOSITION GRATING 1200X600 TO THE DISPLAY TABLE

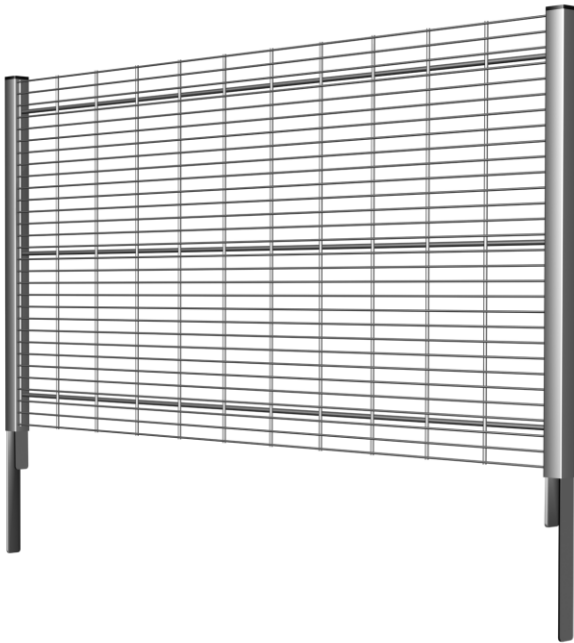

Exposition grating assembled to the display table serve to presentation hanged goods. Easy way of assembly enable to install two grates one on another. The display grating belongs to the additional equipment and it's adapted to assembly on the display table 1200.

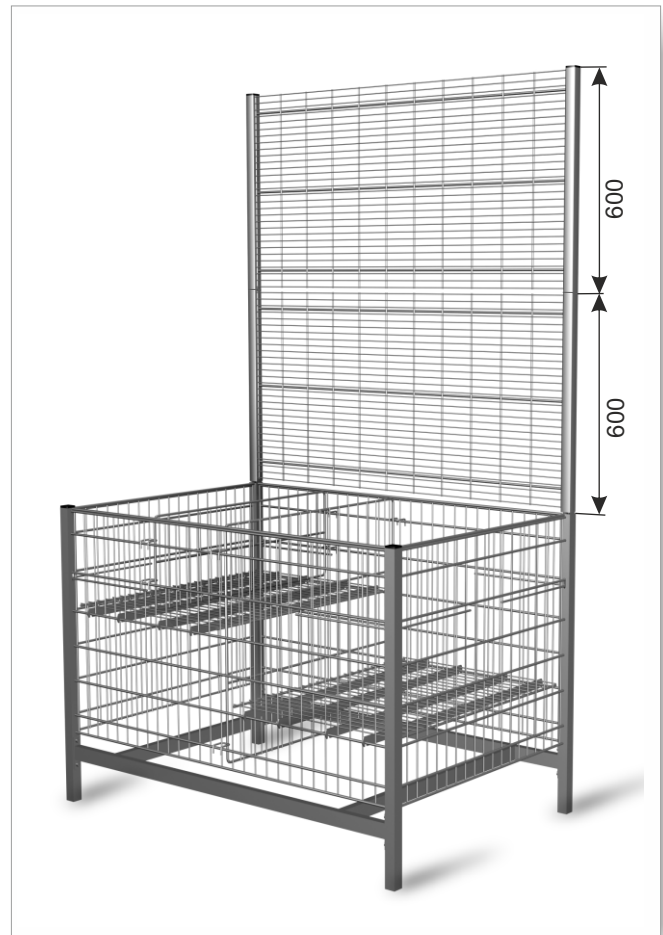

**Standard finish:** zinc plated + lacquer.  
**Technical data:** gratemade of flat iron and steelwire.

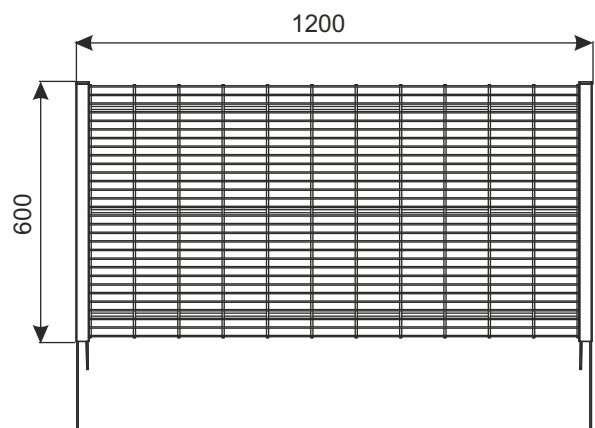

PRODUCT NAME	FINISH	FINISH
Exposition grating 1200x600 to the display table	zinc plated + lacquer	919-350-773

### **E1** DISPLAY TABLES, WIRE BASKETS

## DUMPING BASKET ON LEGS 54x54x82 CM

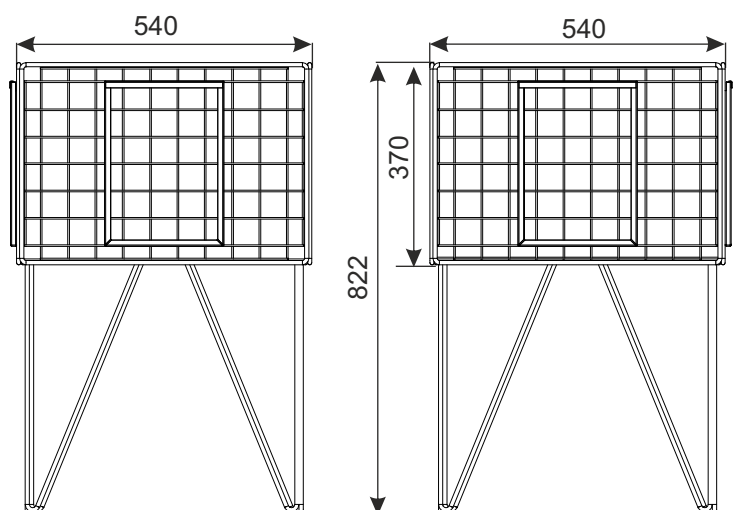

The ideal tool for promotion, sales and marketing campaigns.  
**Finish:** zinc plated + lacquer.  
**Technical data:** Structure made of spot welded wires.  
**Maximum loading:** 75 kg

PRODUCT NAME	FINISH	INDEX
Dumping basket on legs 54X54X82 cm	zinc plated + lacquer	919-351-080

### E1 DISPLAY TABLES, WIRE BASKETS

## IN-OUT BASKET 615X650X860



In-out folded basket allows for presentation and sale goods. It has light and convenient construction, castors and the possibility to adjust a height of the basket's bottom. It's small dimensions after folding means that when a basket isn't being used, it doesn't take up excessive warehouse space. In-out basket can be used in markets, warehouses, gas stations and offices.

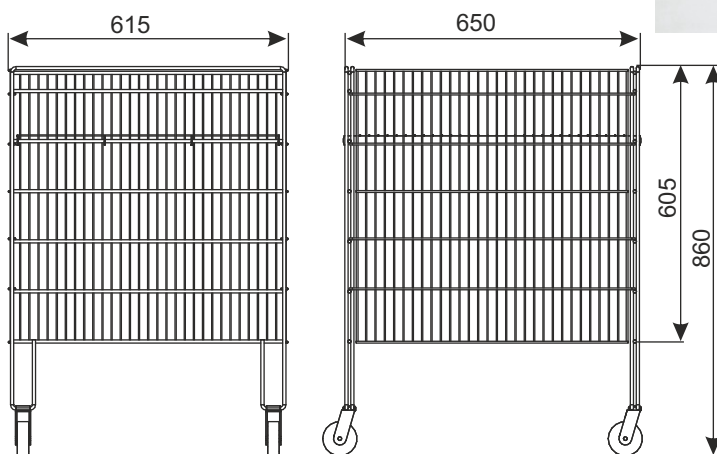

**Standard finish:** zinc plated + lacquer.

Technical data: The structure made of wire; wire shelf, reinforced with flat iron, can be hanged on different height; swivel castors Ø75 mm with brakes 4 pcs.

**Maximum loading:**

(with equable spreading of the goods): 60 kg.

PRODUCT NAME	FINISH	INDEX
In-out Basket 615x650x860	zinc plated + lacquer	919-350-799

### E1 DISPLAY TABLES, WIRE BASKETS

## FOLDING BASKET DSK16 (550X390X770)



Basket after folding down

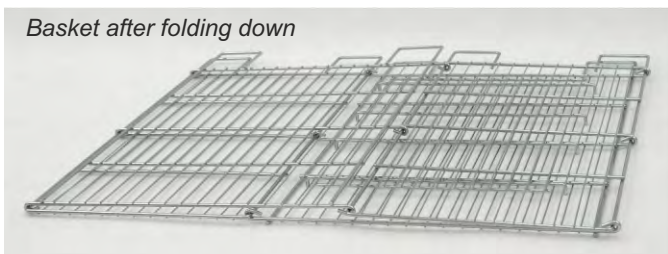

Its folded design ensures an attractive exposition. Folding baskets are used in the stores, warehouses, petrol stations, offices and households. Construction enable to adjust the height of the bottom. Ideal tool to promote, sell and marketing actions.

**Standard finish:** zinc plated + lacquer.

**Technical data:** Structure made of spot welded wires. The basket has folding sides and a bottom that can be placed at various heights.

**Maximum loading:** 40 kg

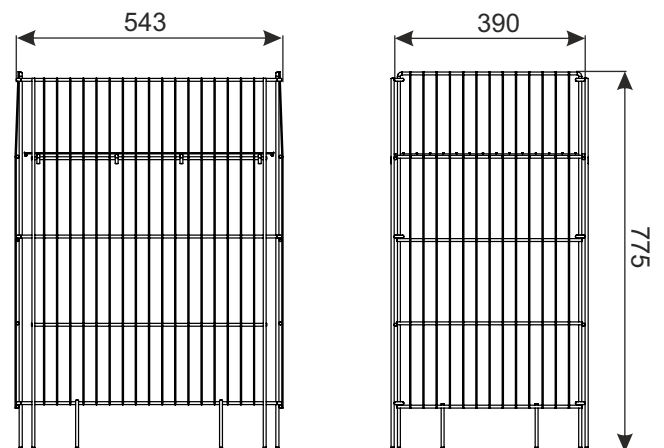

PRODUCT NAME	FINISH	INDEX
Folding basket DSK16 (550x390x770)	zinc plated + lacquer	919-351-128

### E1 DISPLAY TABLES, WIRE BASKETS

## FOLDING BASKET DSK 18 (550X550X770)



Basket after folding down

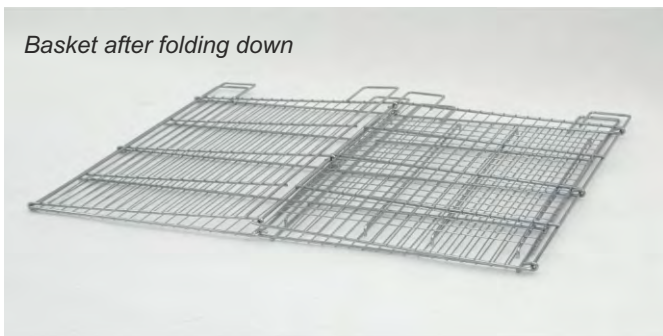

Its folded design ensures an attractive exposition. Folding baskets are used in the stores, warehouses, petrol stations, offices and households. Construction enable to adjust the height of the bottom. Ideal tool to promote, sell and marketing actions.

**Standard finish:** zinc plated + lacquer.

**Technical data:** Structure made of spot welded wires. The basket has folding sides and a bottom that can be placed at various heights.

**Maximum loading:** 50 kg

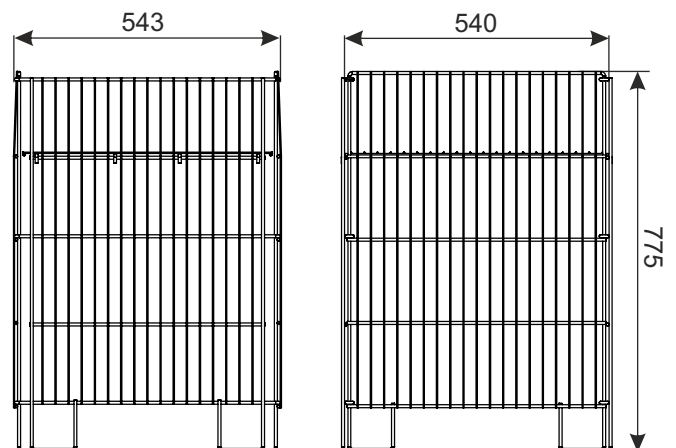

PRODUCT NAME	FINISH	INDEX
Folding basket DSK18 (550x550x770)	zinc plated + lacquer	919-351-132

### E1 DISPLAY TABLES, WIRE BASKETS

## FOLDING BASKET DSK 800X800 H780



*Basket after folding down*

Its folded design ensures an attractive exposition. Folding baskets are used in the stores, warehouses, petrol stations, offices and households. Construction enable to adjust the height of the bottom. Ideal tool to promote, sell and marketing actions.

**Standard finish:** zinc plated + lacquer.

**Technical data:** Structure made of spot welded wires. The basket has folding sides and a bottom that can be placed at various heights.

**Maximum loading:** 50 kg

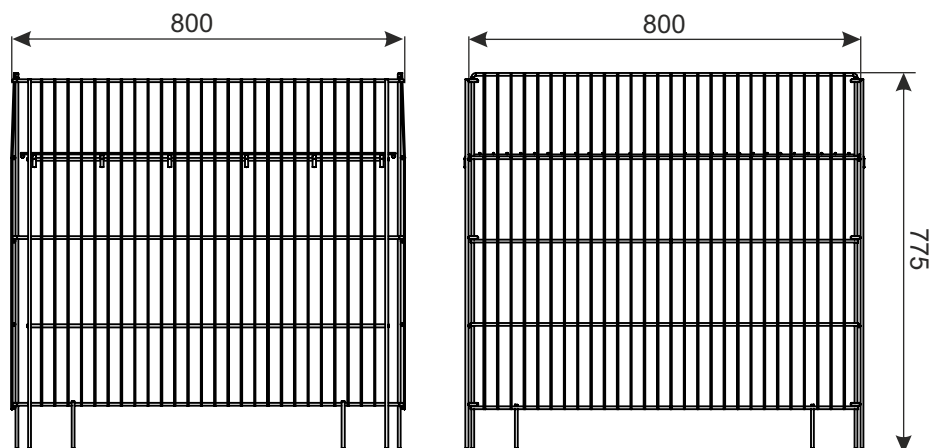

PRODUCT NAME	FINISH	INDEX
Folding basket DSK 800x800 H780	zinc plated + lacquer	919-351-068

### **E1** DISPLAY TABLES, WIRE BASKETS

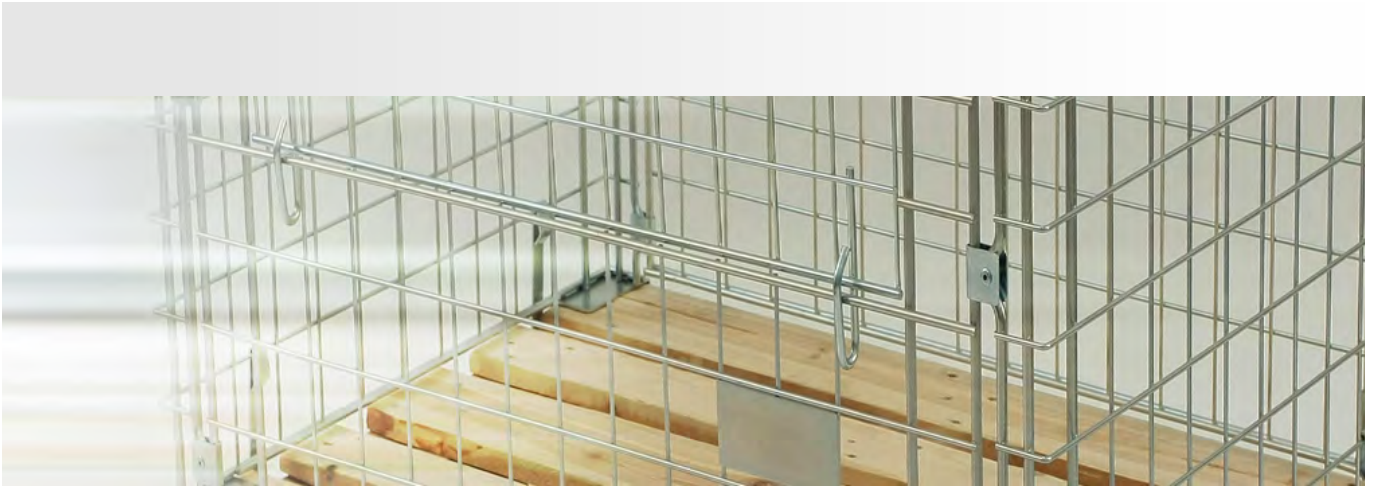

## PALLET CONTAINERS, PALLET BOXES



## **E2** PALLET CONTAINERS, PALLET BOXES

- 1 Folding mesh container 800x600 H680
- 2 Pallet container 1200x800
- 3 Pallet box 1200x800
- 4 Pallet box 1200x800 LIGHT I
- 5 Pallet box 1200x800 LIGHT II
- 6 Dividers to pallet box 1200x800
- 7 A horizontal divider to pallet container 1200x800
- 8 Overhead attachment 12x5 (1140x540)
- 9 Triangular pallet box H-1600
- 10 Pallet box 800x600 LIGHT I

*The reproduce without prior permission is forbidden. In order to improve, the manufacturer reserves the right to implement modifications in its products. Recommendations for installation and use the products are provided for informational purposes only and does not imply any liability on the part of the manufacturer.*

## **E2** PALLET CONTAINERS, PALLET BOXES



## FOLDING MESH CONTAINER 800X600 H680

**NEW!**



The possibility of stacking the containers allows to limit the used storage space.



This pallet container is a full value container, making it possible to store and transport loose goods, without using euro pallets.

**Standard finish:** zinc plated + lacquer.

**Technical data:** The pallet container is made of steel wires (spot welded mesh), on front side it has a half-opened frame.

**Loading capacity** (with equable spreading of the goods):

1 pallet container: 400 kg,

2 pallet containers: 400 kg+300 kg,

3 pallet containers: 300 kg+300 kg+300 kg.

A half-open frame on the front wall allows for easy access to the goods stored inside the container.

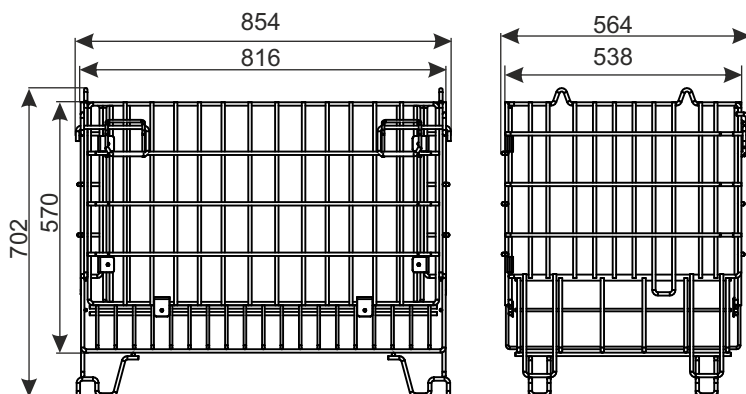
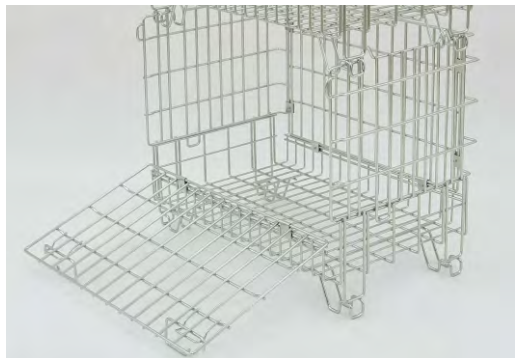

Compact dimensions after folding.



PRODUCT NAME	FINISH	INDEX
Folding mesh container 800x600 H680	zinc plated + lacquer	919-351-477

### **E2** PALLET CONTAINERS, PALLET BOXES

## PALLET CONTAINER 1200x800



This pallet container is a full value container, making it possible to store and transport loose goods, without using euro pallets. It allows for stacking up to three containers (pallet container and the pallet) and reducing to 1/4th the warehouse floor space necessary to store the same quantity of goods. Metal feet allow the container to be lifted up by a fork-lift and also facilitate cleanliness in the warehouse.

During transportation, it is possible to stack two of these containers, one on the other (total height of 1900mm), allowing for optimal utilization of the vehicle's cargo carrying capacity. A half-open frame on the front wall allows for easy access to the goods stored inside the container. The ability to place substantial loads within a single container means that it is not only useful as a container for loosely packed lightweight goods, but also as a stable system for organizing heavier products within a small amount of floor space, maintaining easiness of their movement. Its small dimensions after folding means that when a container is not being used, it does not take up unnecessary warehouse space.



**Standard finish:** zinc plated + lacquer.

**Technical data:** The pallet container is made of steel wires (spot welded mesh). From the top, it is finished with z-profiles. On front side it has a half-opened frame.

**Loading capacity** (with equable spreading of the goods):

- 1 pallet container: 1000 kg,
- 2 pallet containers: 1000 kg+750 kg,
- 3 pallet containers: 750 kg+750 kg+500 kg,
- 4 pallet containers: 500 kg+500 kg+500 kg+500 kg.

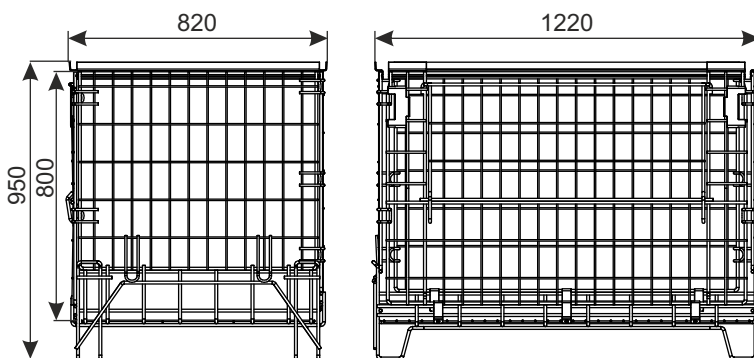

PRODUCT NAME	FINISH	INDEX
Pallet container 1200x800	zinc plated + lacquer	919-350-656

### E2 PALLET CONTAINERS, PALLET BOXES

## PALLET BOX 1200X800



This pallet box together with the wooden pallet creates a full value container, making it possible to store and transport loose goods, using of the pallets. It allows for stacking up to three units (pallet box with a pallet) and reducing to 1/4th the warehouse floor space necessary to store the same quantity of goods. During transportation it is possible to stack two pallet boxes with pallets (total height of 2040 mm), allowing for optimal utilization of the vehicle's cargo carrying capacity. A half-opened frame on the front or side wall allows for easy access to the goods stored inside the box.

The ability to place substantial loads within a single box means that it is not only useful as a container for loosely packed lightweight goods, but also as a stable system for organizing heavier products within a small amount of floor space, maintaining easiness of their movement. Its small dimensions after folding (thickness of only 90mm) means that when a box is not being used, it does not take up excessive warehouse space.

**Additional accessories:** divider H-766 (to pallet box 1200x800)

**Standard finish:** zinc plated + lacquer.

**Technical data:** The structure of the box is made of steel wires and spot welded mesh. From the bottom and the top it is finished with z-profiles. Frame opens to the short or long side.

**Loading capacity** (using europallets and when equally loaded):

- 1 pallet box: 900kg;
- 2 pallet boxes: 900kg+750kg;
- 3 pallet boxes: 900kg+500kg+500 kg;
- 4 pallet boxes: 900kg+500kg+300kg+300 kg.

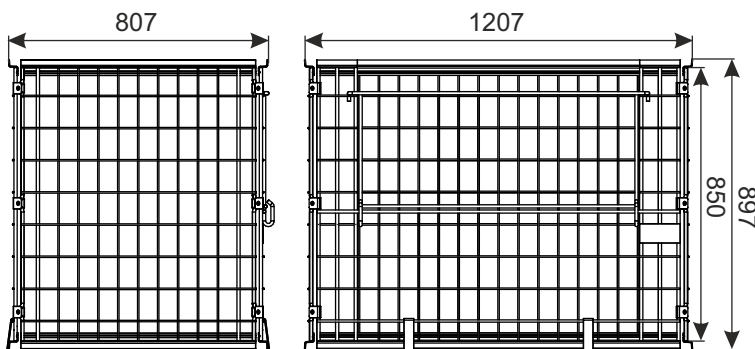

PRODUCT NAME	FINISH	INDEX
Pallet box 1200x800 (opened on the side 1200)	zinc plated + lacquer	919-350-652
Pallet box 1200x800 (opened on the side 800)	zinc plated + lacquer	919-350-658
ADDITIONAL EQUIPMENT	FINISH	INDEX
Divider H-766 (to pallet box 1200x800)	zinc plated + lacquer	919-350-525

*This product is sold without the pallet.*

### E2 PALLET CONTAINERS, PALLET BOXES

## PALLET BOX 1200X800 LIGHT I



This pallet box together with the wooden pallet creates a full value container, making it possible to store and transport loose goods, using of the pallets. It allows for stacking up to three units (pallet box with a pallet) and reducing to 1/4th the warehouse floor space necessary to store the same quantity of goods. During transportation it is possible to stack two pallet boxes with pallets (total height of 1900 mm), allowing for optimal utilization of the vehicle's cargo carrying capacity. An half-opened frame on the front wall (1200 mm) allows for easy access to the goods stored inside the box.

The ability to place substantial loads within a single box means that it is not only useful as a container for loosely packed lightweight goods, but also as a stable system for organizing heavier products within a small amount of floor space, maintaining easiness of their movement. Its small dimensions after folding (thickness of only 90mm) means that when a box is not being used, it does not take up excessive warehouse space.

**Additional accessories:** divider LIGHT H-684 (to pallet box 1200x800 LIGHT)



**Standard finish:** zinc plated + lacquer.

**Technical data:** The structure of the box is made of steel wires and spot welded mesh. From the bottom and the top it is finished with corners made of plate. Frame opens to the front. It is possible to buy the box that opens on the short side.

**Loading capacity** (using europallets and when equally loaded):

- 1 pallet box: 900kg;
- 2 pallet boxes: 900kg+750kg;
- 3 pallet boxes: 900kg+500kg+500kg;
- 4 pallet boxes: 900kg+500kg+300kg+300kg.

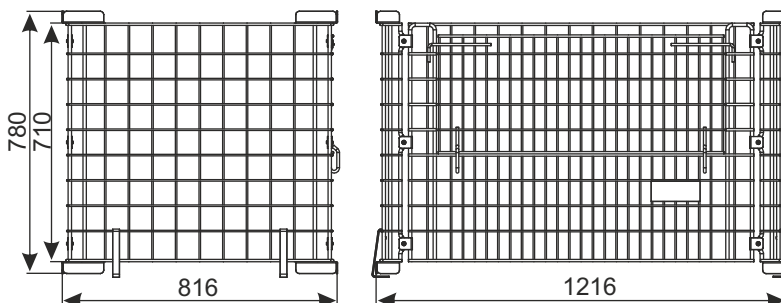

PRODUCT NAME	FINISH	INDEX
Pallet box 1200x800 LIGHT I	zinc plated + lacquer	919-350-649
ADDITIONAL EQUIPMENT	FINISH	INDEX
Divider LIGHT H-684 (to pallet box 1200x800 LIGHT)	zinc plated + lacquer	919-350-744

*This product is sold without the pallet.*

## E2 PALLET CONTAINERS, PALLET BOXES

## PALLET BOX 1200X800 LIGHT II

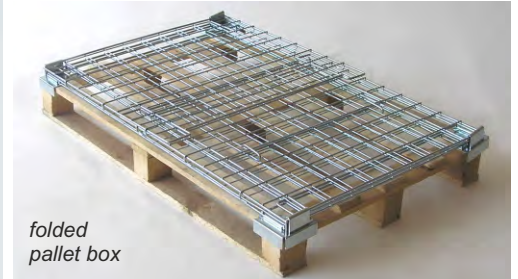

This pallet box together with the wooden pallet creates a full value container, making it possible to store and transport loose goods, using of the pallets. An half-opened frame allows for easy access to the goods stored inside the box.

An ideal container for high storage shelving.

**Standard finish:** zinc plated + lacquer.

**Technical data:** The structure of the box is made of steel wire and spot welded mesh. From the bottom is finished with corners made of plate. Frame can be opened on the long or short side.

**Loading capacity:** 900 kg (using europallets and when equally loaded).

Pallet Box can be folded back flat against the pallet 1200x800. That makes the container easy to transport. Its small dimensions after folding means that when a box is not being used, it doesn't take up warehouse space.

**Additional accessories:** divider LIGHT H-684 to pallet box 1200x800 LIGHT

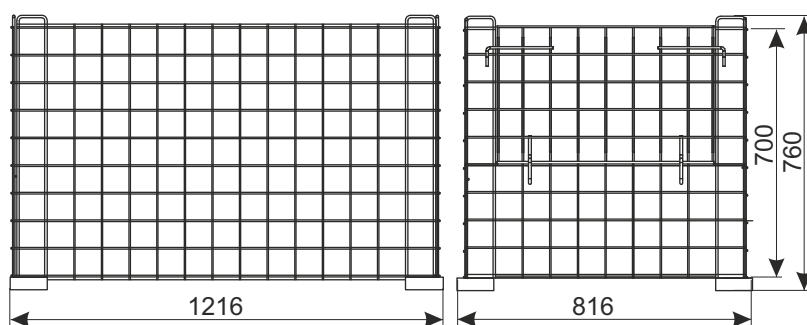

PRODUCT NAME	FINISH	INDEX
Pallet box 1200x800 LIGHT II (opened on the side 1200)	zinc plated + lacquer	919-350-793
Pallet box 1200x800 LIGHT II (opened on the side 800)	zinc plated + lacquer	919-350-783
ADDITIONAL EQUIPMENT	FINISH	INDEX
Divider LIGHT H-684 (to pallet box 1200x800 LIGHT)	zinc plated + lacquer	919-350-744

*This product is sold without the pallet.*

### E2 PALLET CONTAINERS, PALLET BOXES

## DIVIDERS TO PALLET BOX 1200X800



A functional divider made of wire can be used to divide the pallet box into two separate chambers, without impediment of the access by tilting the frame from the front. This allows two different products to be separately stored and transported within a single box.

**Standard finish:** zinc plated + lacquer.

**Divider belongs to the additional equipment and is adapted to assembly to:**

- pallet box (divider H 766 is recommended)
- pallet box Light I (divider H 684 is recommended)
- pallet box Light II (divider H 684 is recommended)

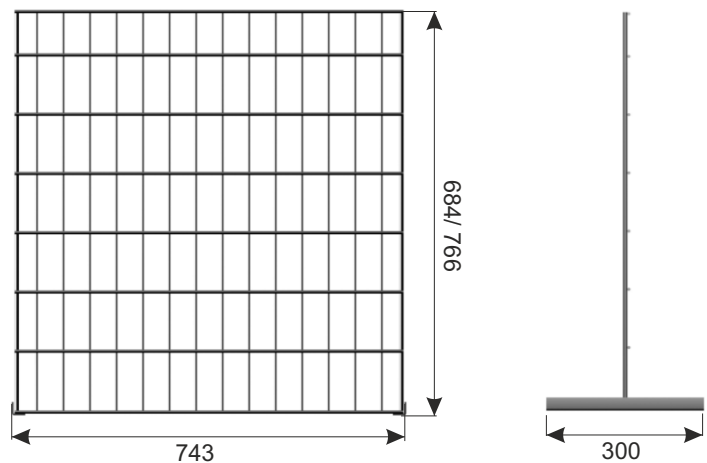

Divider H-766  
with pallet box



Divider H-684  
with pallet box LIGHT I



Divider H-684  
with pallet box LIGHT II

PRODUCT NAME	FINISH	INDEX
Divider H-766 (to pallet box 1200x800)	zinc plated + lacquer	919-350-525
Divider LIGHT H-684 (to pallet box 1200x800 LIGHT)	zinc plated + lacquer	919-350-744

### E2 PALLET CONTAINERS, PALLET BOXES

## A HORIZONTAL DIVIDER TO PALLET CONTAINER 1200x800

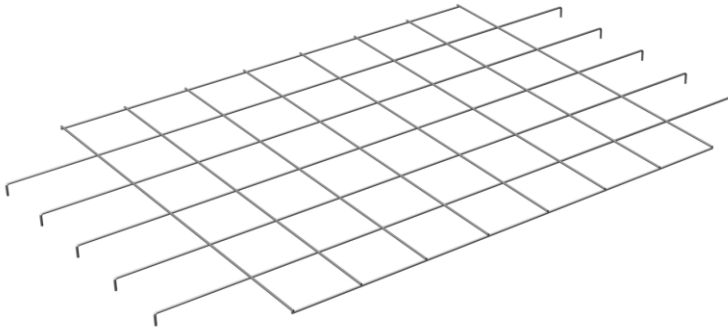

A horizontal divider of wire allow to put goods in form of rolls in a vertical position to protect them to fall over. In order to better stability of a vertical position of goods it is recommended to mount two horizontal dividers in a pallet container – one on the bottom of pallet container, second in the upper part of pallet container.

**Finish:** galvanic zinc.

**A divider is an additional equipment and it is adapted to mount on product:**  
- pallet container 1200x800

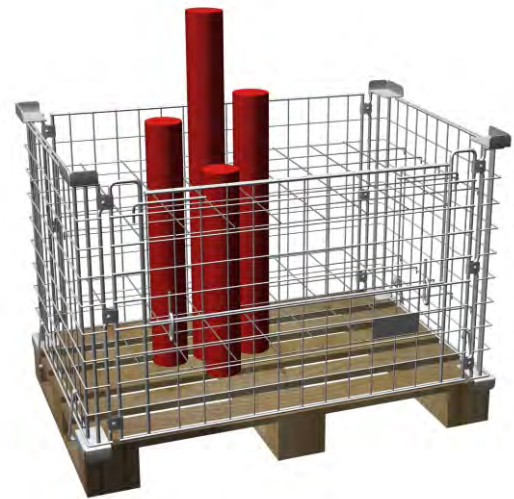

*example of using*

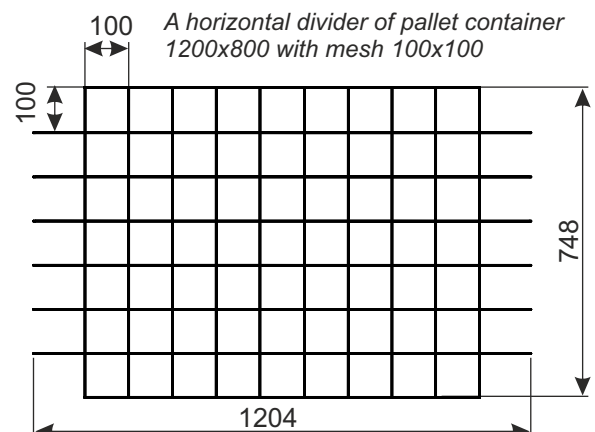
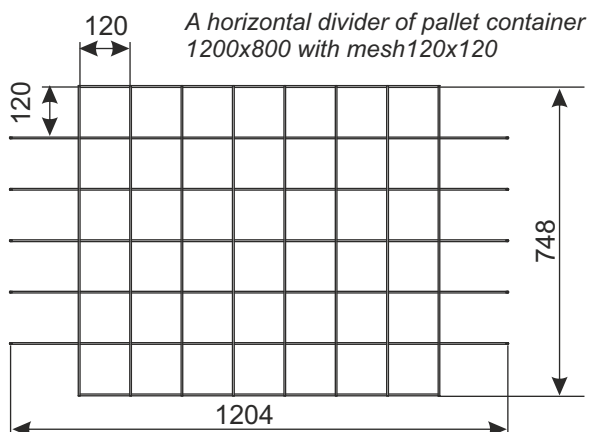

PRODUCT NAME	FINISH	INDEX
A horizontal divider to pallet container 1200x800 with mesh 120x120	zinc plated	919-350-781
A horizontal divider to pallet container 1200x800 with mesh 100x100	zinc plated	919-350-857

### **E2** PALLET CONTAINERS, PALLET BOXES

## OVERHEAD ATTACHMENT 12x5 (1140x540) MOUNTED ON PALLET CONTAINER 1200x800 LIGHT I

Assembly of overhead attachment  
on pallet container LIGHT I

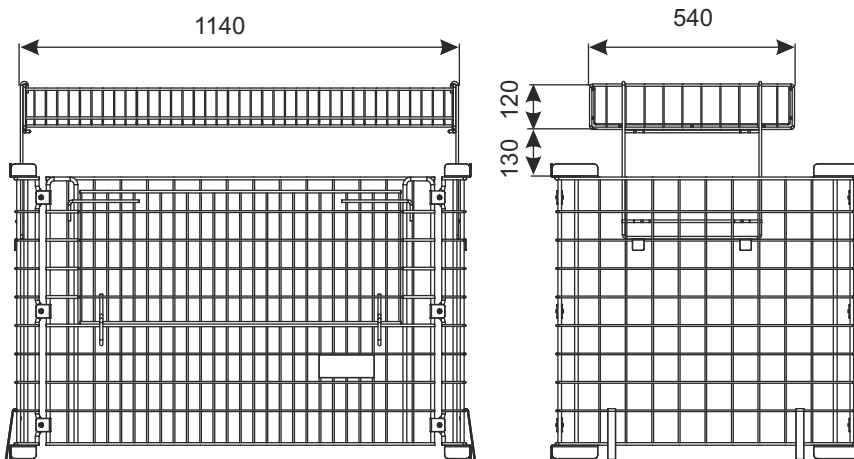

Overhead attachment is a simple and reliable way to expose light products with small dimensions. An easy assembly on pallet container 1200x800 LIGHT I allows to exposition of bigger amount of products and it is additional sales area. Overhead attachment is mounted on:  
- pallet container LIGHT I 1200x800

**Standard finish:** zinc plated + lacquer or bright chrome.

**Technical data:** basket and holders made of wire.

**Maximum loading:** ca 20 kg (with equable spreading of the goods).

PRODUCT NAME	FINISH	INDEX
Overhead attachment 12x5 (1140x540)	bright chrome	919-320-535
Overhead attachment 12x5 (1140x540)	zinc plated	919-350-821

### E2 PALLET CONTAINERS, PALLET BOXES



## TRIANGULAR PALLET BOX H-1600



This pallet together with the wooden pallet creates a full value container, making it possible to store and transport loose goods, using of the pallets.

**Standard finish:** zinc plated + lacquer.

**Technical data:** The structure of the box is made of steel wire and spot welded mesh. From the bottom is finished with corners made of plate. **To the pallet box can be mounted horizontal divisions.** The number of horizontal divisions for the set - to be agreed. There is a possibility of adjust the height of the divisions.

**Loading capacity** (using europallets and when equally loaded):  
single horizontal division: 50 kg,  
total loading: 1000 kg.

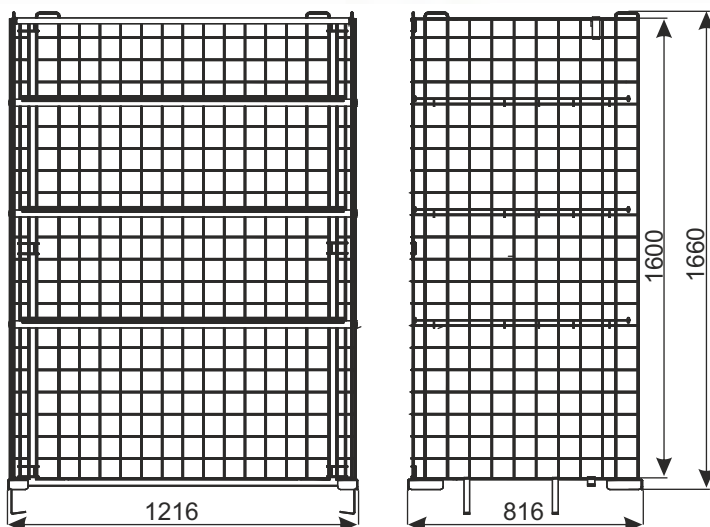

Its small dimensions after folding means that when a box is not being used, it doesn't take up warehouse space.

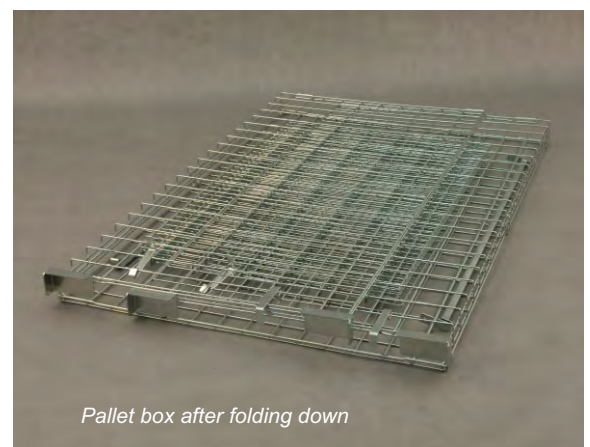

PRODUCT NAME	FINISH	INDEX
Triangular pallet box H-1600 (without horizontal divisions)	zinc plated + lacquer	919-350-853
Horizontal division for Triangular pallet box H-1600	zinc plated + lacquer	919-350-859

*This product is sold without the pallet.*

### E2 PALLET CONTAINERS, PALLET BOXES

## PALLET BOX 800X600 LIGHT I



This pallet box together with the wooden pallet creates a full value container, making it possible to store and transport loose goods, using of the pallets. There is a possibility of stacking up the pallet boxes, which allows to reduce the warehouse floor space necessary to store the same quantity of goods. An half-opened frame allows for easy access to the goods stored inside the box.

The ability to place substantial loads within a single box means that it is not only useful as a container for loosely packed lightweight goods, but also as a stable system for organizing heavier products within a small amount of floor space, maintaining easiness of their movement. Its small dimensions after folding (thickness of only 90mm) means that when a box is not being used, it does not take up excessive warehouse space.

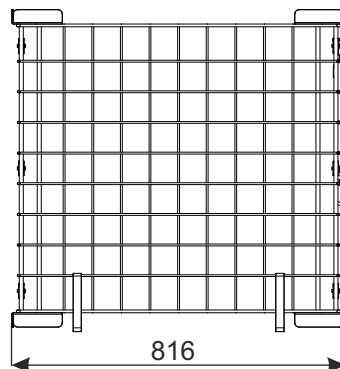
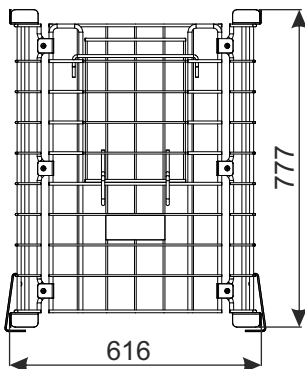

**Standard finish:** zinc plated + lacquer.

**Technical data:** The structure of the box is made of steel wires and spot welded mesh. From the bottom and the top it is finished with corners made of plate. An half-opened frame on the side wall.

**Loading capacity** (with equable spreading of the goods):

1 pallet container: 400 kg,

2 pallet containers: 300 kg+200 kg,

3 pallet containers: 200 kg+200 kg+100 kg.

PRODUCT NAME	FINISH	INDEX
Pallet box 800x600 LIGHT I opened on the side 600	zinc plated + lacquer	919-351-048

### E2 PALLET CONTAINERS, PALLET BOXES

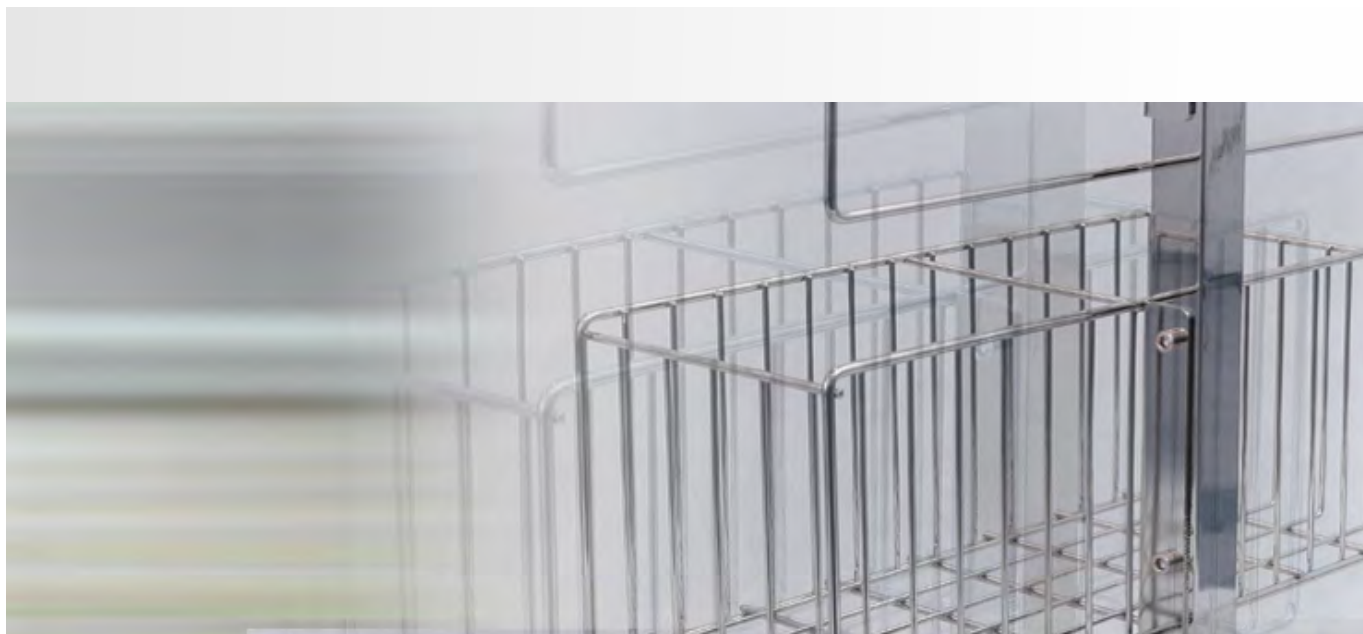

**SPECIAL RETAIL EQUIPMENT**



## **E3** SPECIAL RETAIL EQUIPMENT

- 1 Packaging table
- 2 Isothermal bag's rack
- 3 Double basket for bags on roll
- 4 The grip to the basket for bags on roll fixed to the shelf bracket
- 5 The rack with the grip to the basket for bags on roll
- 6 Rack for poly bags, paper bags and gloves
- 7 Stand with tray for flyers A4 and A5
- 8 Grip with the tray for flyers A4 and A5
- 9 Grip with tray for flyers A4 and A5 mounted on screw
- 10 Vegetable stand S2 with regulation
- 11 Vegetable stand S3 with regulation
- 12 Stand for cut flowers
- 13 Corner shelf for flowers
- 14 3-shelf stand with regulation
- 15 Round basket KO-850x600
- 16 Stand ofor waste segregation (for 3 sacks)
- 17 Lockers for clients bags
- 18 Outdoor gondola
- 19 Accessories for cooling devices

*The reproduce without prior permission is forbidden. In order to improve, the manufacturer reserves the right to implement modifications in its products. Recommendations for installation and use the products are provided for informational purposes only and does not imply any liability on the part of the manufacturer.*

## **E3** SPECIAL RETAIL EQUIPMENT

## PACKAGING TABLE



Packaging table is used to packing and repacking of the goods bought in the shop.

**Standard finish:** powder coated, wire mesh zinc plated.

**Technical data:** structure made of sections, table top made of metal sheet, lower shelf made of steel wires.

**Maximum loading:** upper shelf ca 200 kg, lower shelf ca 100 kg (with equable spreading of the goods).

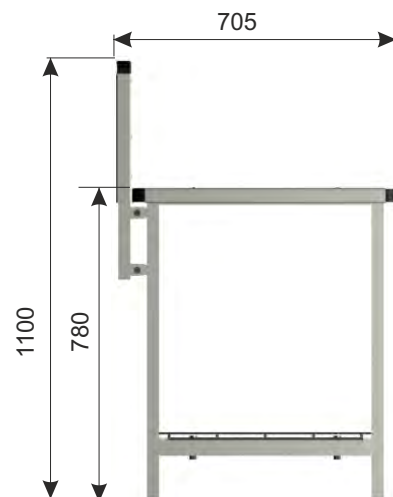
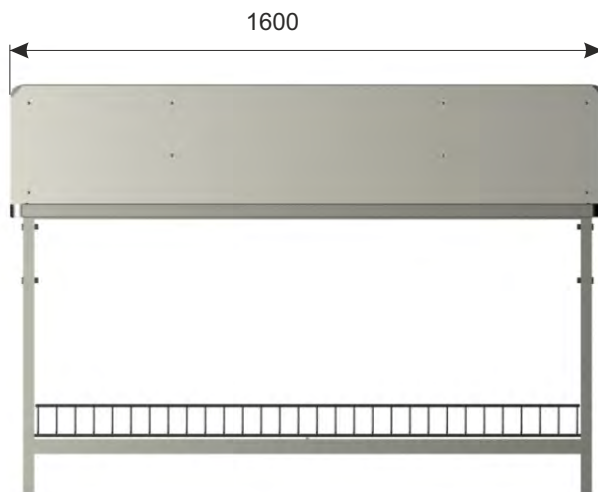

PRODUCT NAME	FINISH	INDEX
Packaging table	powder coated	919-343-025

### E3 SPECIAL RETAIL EQUIPMENT

## ISOTHERMAL BAG'S RACK



The freestanding rack allows for presentation and sell isothermal bags. It is used mostly next to the cooling devices.

**Standard finish:** zinc plated + lacquer.

**Technical data:** Rack composed of elements: base made of bended plate and leg made of section with welded flat, which is used to assembly rack to the base. Grip for isothermal bags, made of wire and flat, can be assembly to the rack . Assembly to the ground with chemical anchor.

**Maximum loading:** 5 kg.

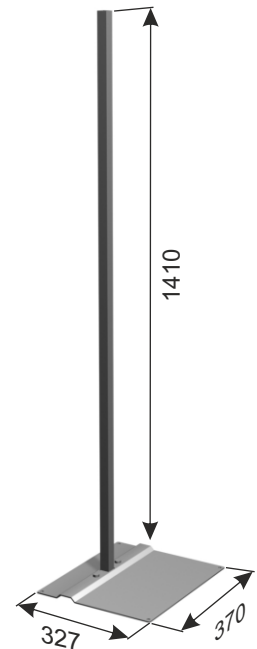

### ■ ADDITIONAL ACCESORIES:

Grip to the rack for isothermal bags

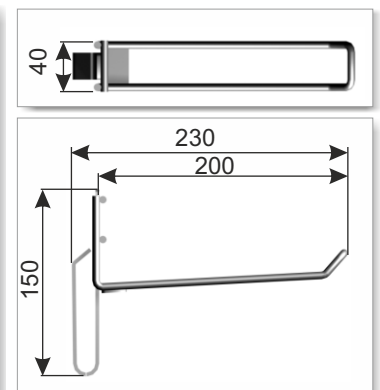
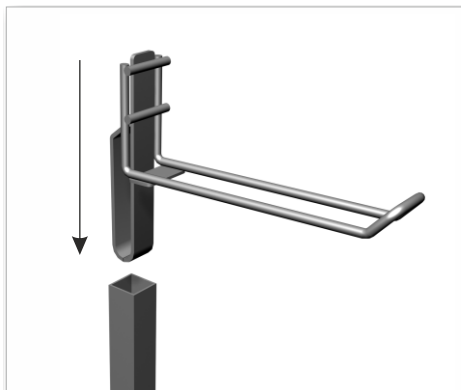

PRODUCT NAME	FINISH	INDEX
Isothermal bag's rack	zinc plated + lacquer	919-350-698
ADDITIONAL EQUIPMENT	FINISH	INDEX
Grip to the rack for isothermal bags	zinc plated + lacquer	919-350-699

### E3 SPECIAL RETAIL EQUIPMENT

## DOUBLE BASKET FOR BAGS ON ROLL

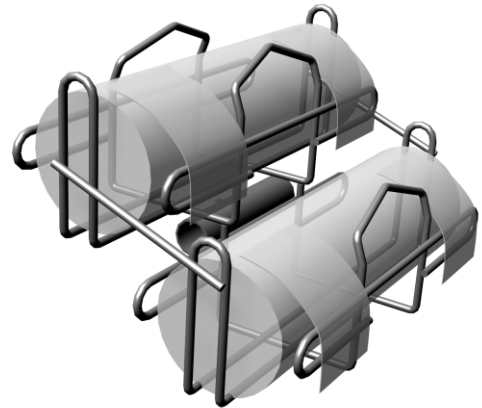

Basket for bags on roll is hopper for rolls with plastic bags. It is used to place bags on roll in a convenient place (e.g. near the vegetable stand). Thanks three kind of grips the basket can be fixed in any place in any configuration on the vegetable stand.

**Standard finish:** zinc plated + lacquer.

**Technical data:** Basket made of wire and tube.

**Maximum loading:** ca 10 kg.

**Capacity of the basket:**

- maximum diameter of roll  $\varnothing$  85 mm,
- maximum length of roll 260 mm.

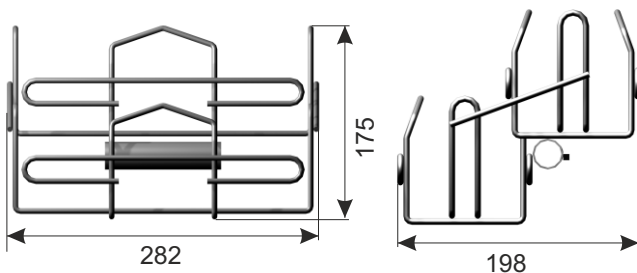

### ADDITIONAL ACCESORIES:

The grip to the basket fixed to the shelf bracket (right, left, universal)

The rack with the grip to the basket for bags on roll

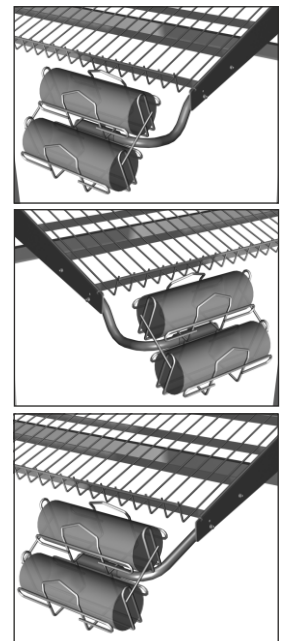

PRODUCT NAME	FINISH	INDEX
Double basket for bags on roll	zinc plated + lacquer	919-350-685
ADDITIONAL EQUIPMENT	FINISH	INDEX
Right grip for basket for bags on roll	zinc plated + lacquer	919-350-688
Left grip for basket for bags on roll	zinc plated + lacquer	919-350-687
Universal grip for basket for bags on roll	zinc plated + lacquer	919-350-686
The rack with the grip to the basket for bags on roll	zinc plated + lacquer	919-350-828

### E3 SPECIAL RETAIL EQUIPMENT

## THE GRIP TO THE BASKET FOR BAGS ON ROLL FIXED TO THE SHELF BRACKET

The grip is designed for fixing a basket for bags on roll on the racks shelf by screwing the grip to the shelf bracket. The basket for bags on roll is fixed to the grip by putting the basket onto the tube and fasten by screw.

**Standard finish:** zinc plated + lacquer.

**Technical data:** Grip made of tube and section.

**Maximum loading:** ca 10 kg.

### Right grip

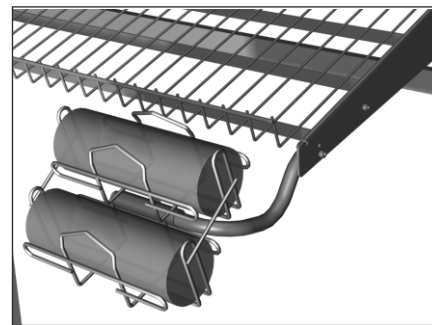
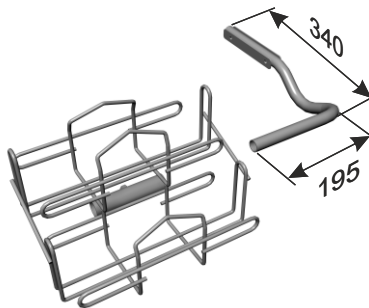

### Left grip

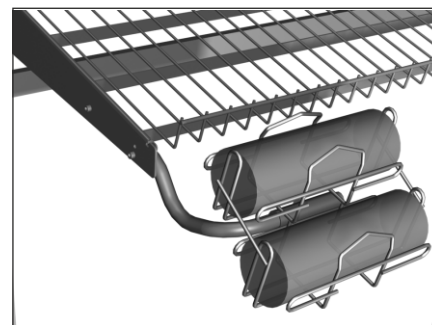
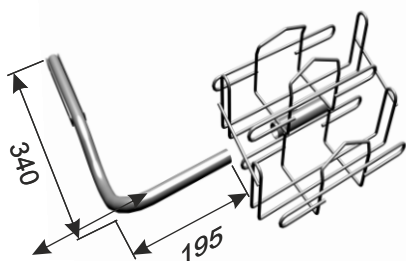

### Universal grip

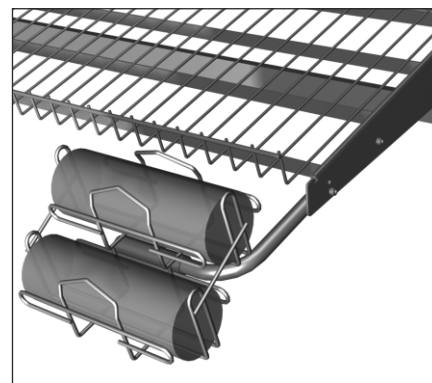
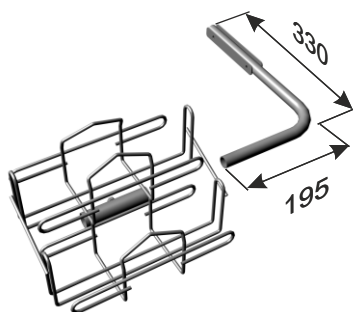

PRODUCT NAME	FINISH	INDEX
Right grip to the basket for bags on roll fixed to the shelf bracket	zinc plated + lacquer	919-350-688
Left grip to the basket for bags on roll fixed to the shelf bracket	zinc plated + lacquer	919-350-687
Universal grip to the basket for bags on roll fixed to the shelf bracket	zinc plated + lacquer	919-350-686
ELEMENTS ADAPTED FOR ASSEMBLY WITH THE GRIP	FINISH	INDEX
Double basket for bags on roll	zinc plated + lacquer	919-350-685

## E3 SPECIAL RETAIL EQUIPMENT



## THE RACK WITH THE GRIP TO THE BASKET FOR BAGS ON ROLL



Stand for the basket on a roll is one of the solutions to put rolls of foil bags anywhere in the store, including, inter alia, the fruit and vegetable stand.

**Standard finish:** zinc plated + lacquer.

**Technical data:** Leg is made of the pipe, base made of plate. The basket is fixed to the rack by screwing the basket to the racks leg.

**Maximum loading:** ca 10 kg.

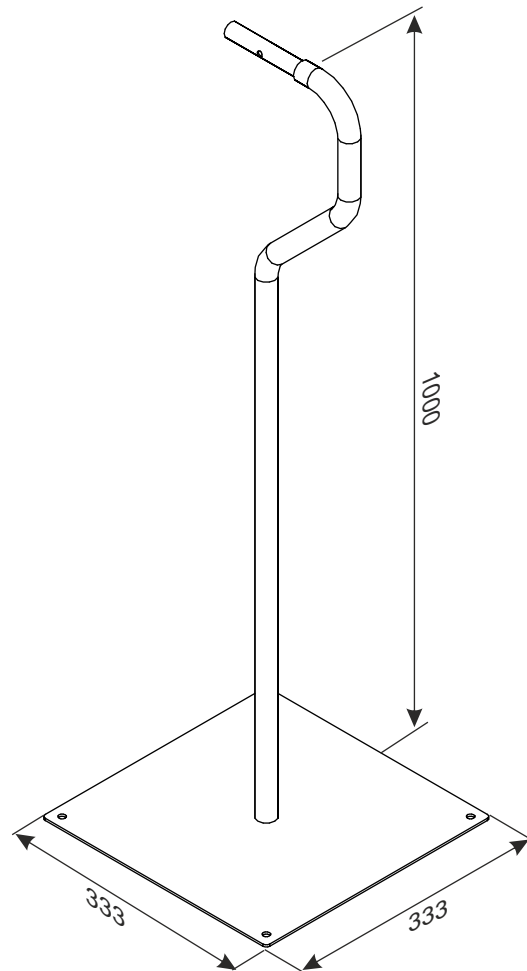

PRODUCT NAME	FINISH	INDEX
The rack with the grip to the basket for bags on roll	zinc plated + lacquer	919-350-828

ELEMENTS ADAPTED FOR ASSEMBLY WITH THE GRIP	FINISH	INDEX
Double basket for bags on roll	zinc plated + lacquer	919-350-685

### E3 SPECIAL RETAIL EQUIPMENT

## RACK FOR POLY BAGS, PAPER BAGS AND GLOVES

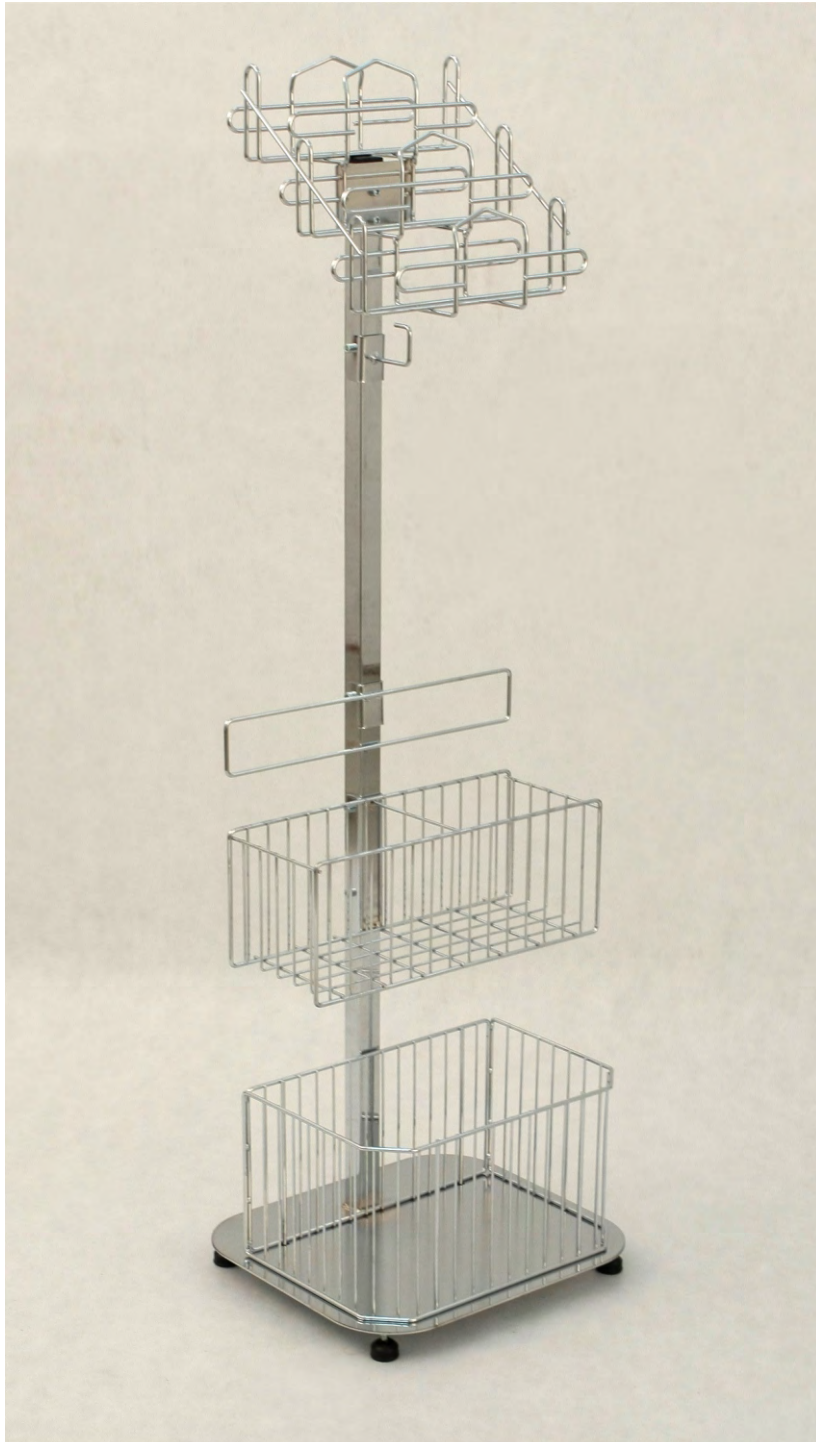

**Standard finish :** chrome

**Technical data:** The structure made of section, plate and wire. Components screwed with screws.

**Maximum loading:**  
 Grip for poly bags - 10 kg,  
 Hook for gloves - 5 kg,  
 Basket for bags - 10 kg,  
 Bottom shelf - 20 kg.

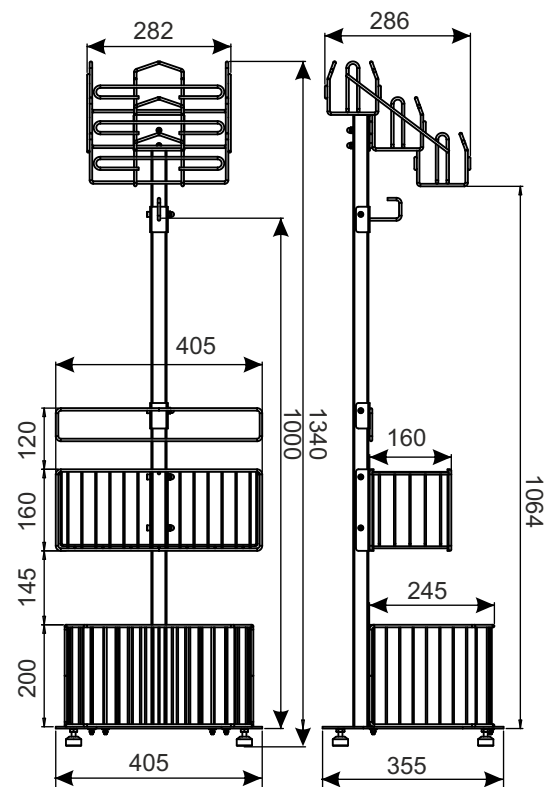

PRODUCT NAME	FINISH	INDEX
Rack for poly bags, paper bags and gloves	chrome	919-320-568

### E3 SPECIAL RETAIL EQUIPMENT

## STAND WITH TRAY FOR FLYERS A4 AND A5

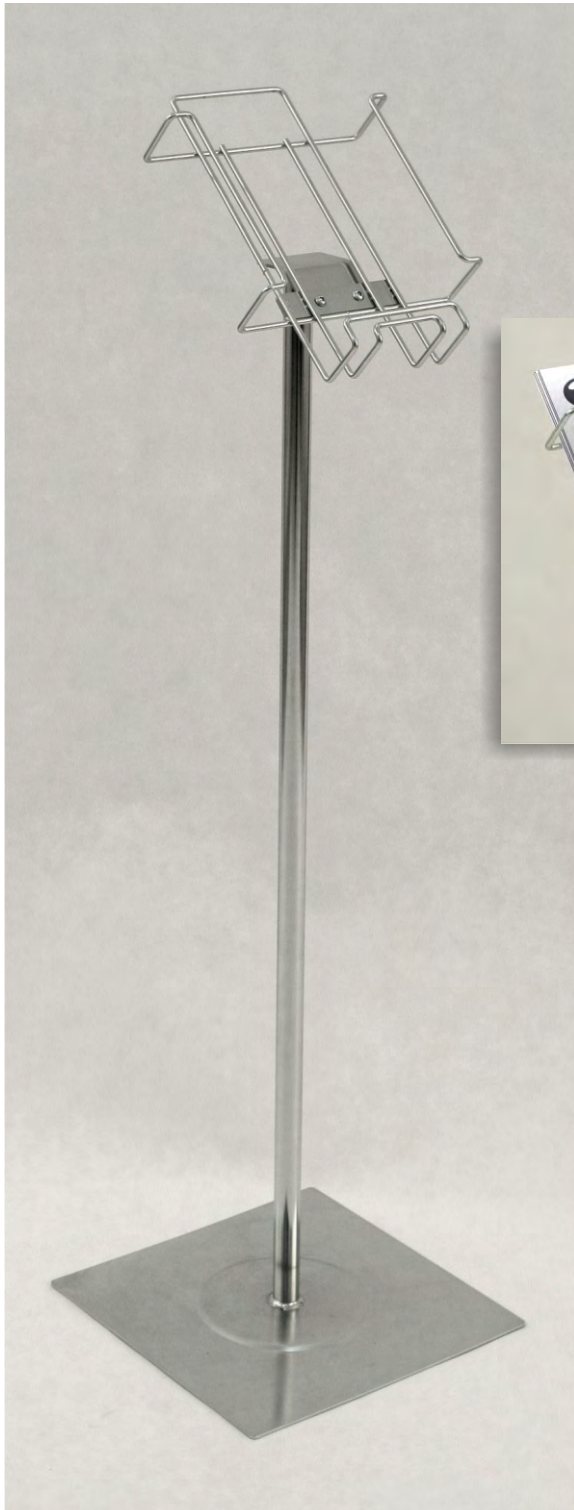

Stand with tray for flyers serves as a freestanding display for flyers A4 and A5

**Standard finish:** zinc plated + lacquer.

**Technical data:** Construction of the stand is made of bent pipe, metal base and grip made of metal plate. The tray for leaflet is bolted to the grip. The tray is made of wire.

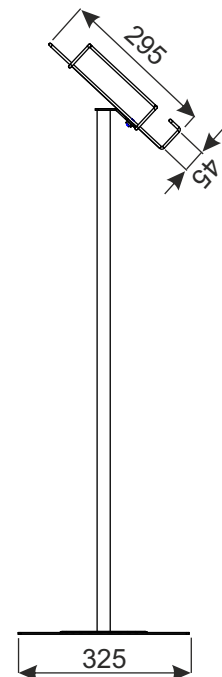
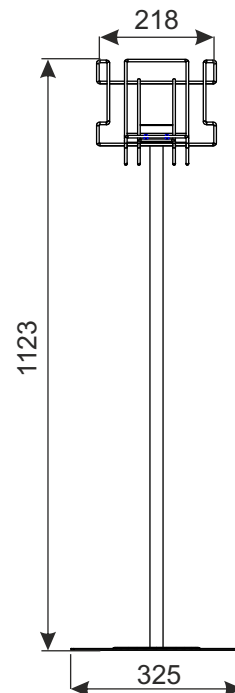
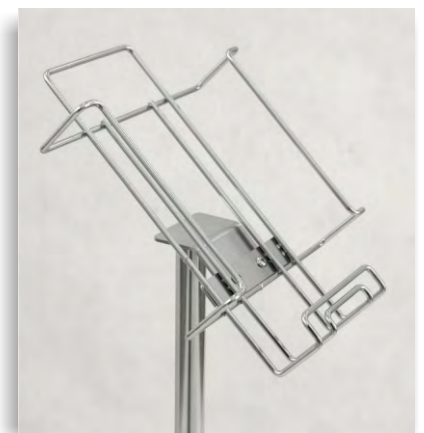

PRODUCT NAME	FINISH	INDEX
Stand with tray for flyers A4 and A5	zinc plated + lacquer	919-351-031

### E3 SPECIAL RETAIL EQUIPMENT

## GRIP WITH THE TRAY FOR FLYERS A4 AND A5

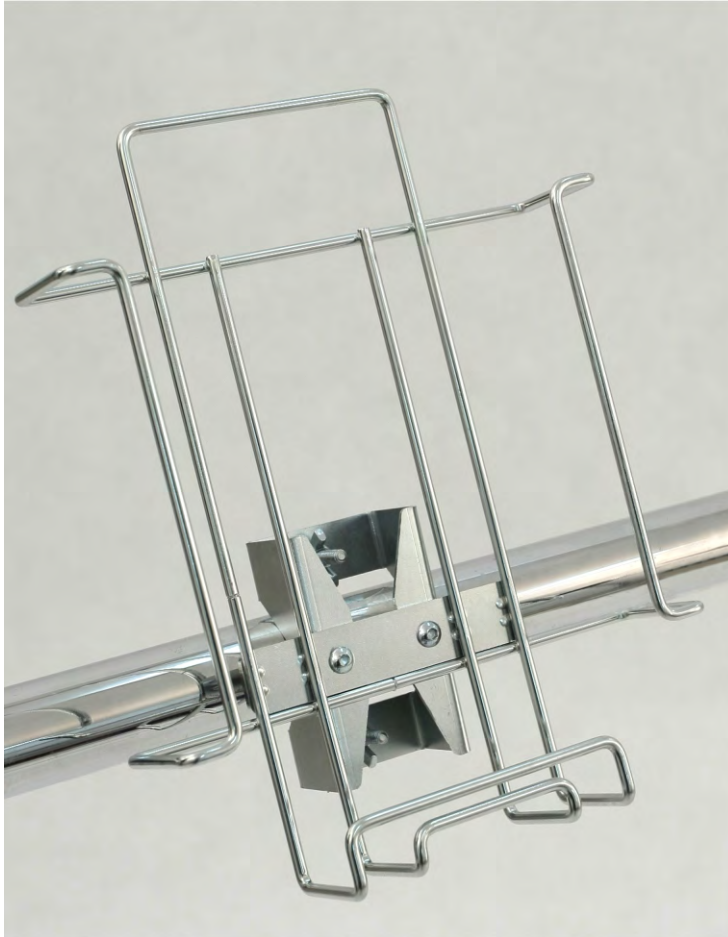

The grip with the tray serves as a display for leaflets A4 and A5. Grip is mounted on a horizontal pipe which is for example the part of customer guidance system or trolley pass.

**Standard finish:** zinc plated + lacquer.

**Technical data:** Construction of grip is made of metal plate, to which the tray for leaflet is bolted. The tray is made of wire. The grip is mounted on a horizontal pipe using the mounting rod tightened with wing nuts.

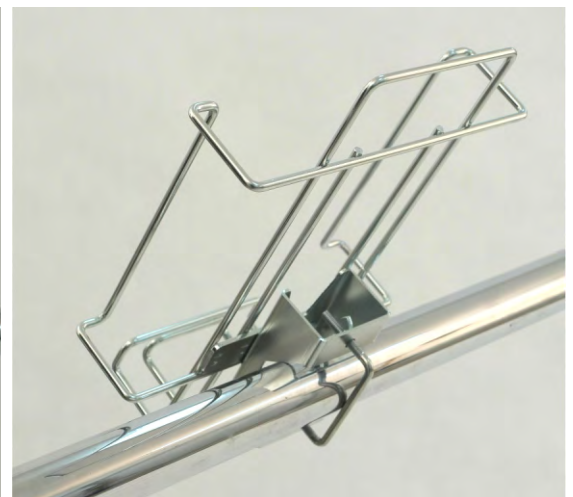
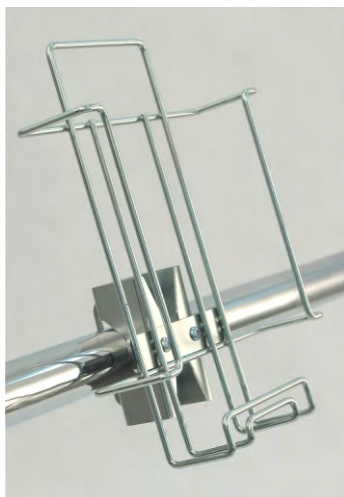
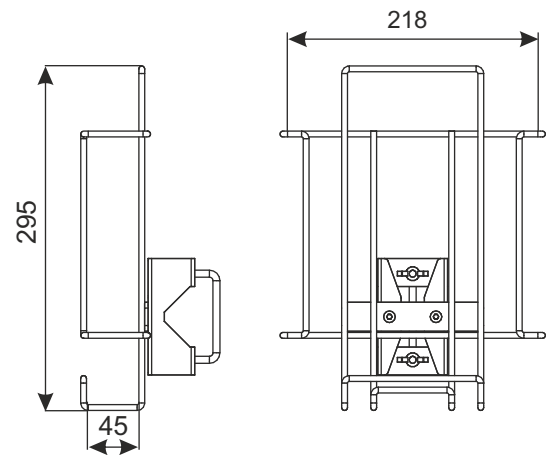

PRODUCT NAME	FINISH	INDEX
Grip with the tray for flyers A4 and A5	zinc plated + lacquer	919-351-032

### E3 SPECIAL RETAIL EQUIPMENT

DAMIX Sp z o.o. ul. Bohaterów Czerwca 1956r. nr 3; PL - 87-500 Rypin  
tel. +48 54 280 34 93; fax +48 54 280 45 40; e-mail: damix@damix.pl; handel@damix.pl, www.damix.pl

All rights reserved  
05 03 2018

## GRIP WITH TRAY FOR FLYERS A4 AND A5

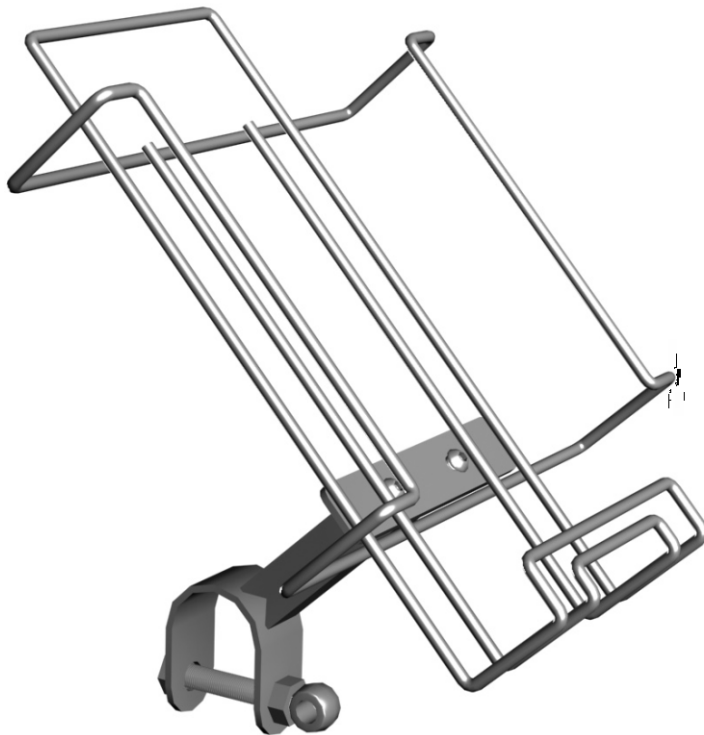

The grip with the tray serves as a display for leaflets A4 and A5. Grip is mounted on a horizontal pipe which is for example the part of customer guidance system or trolley pass.

**Standard finish:** zinc plated + lacquer.

**Technical data:** Grip with tray is turned by screws. A tray made of wire. Grip is mounted on horizontal tube  $\varnothing 40$  mm through its application on the tube and tightening screw fixing.

*An example of application – assembly on partition:*

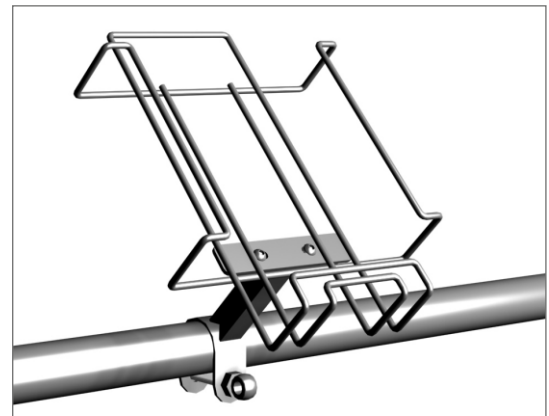

*An example of application – assembly on entry barrier:*

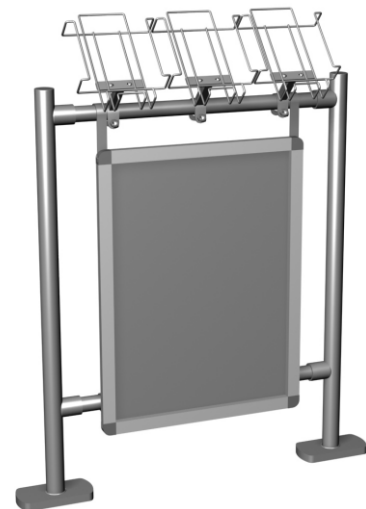
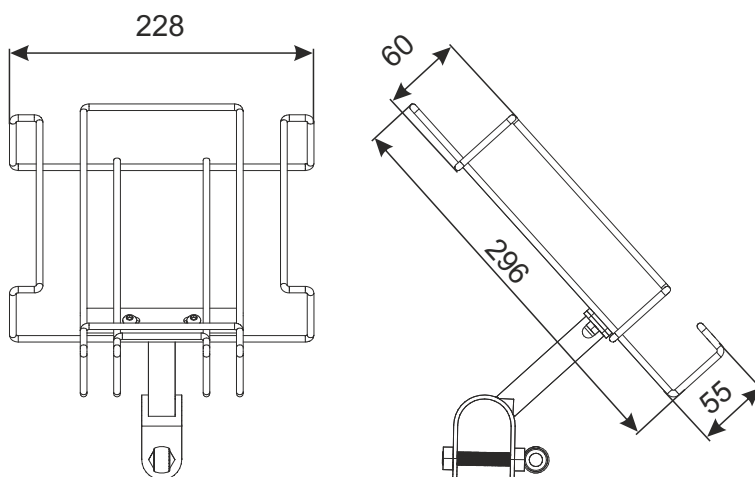

PRODUCT NAME	FINISH	INDEX
Grip with tray for flyers A4 and A5 mounted on screw	zinc plated + lacquer	919-351-259v2

### E3 SPECIAL RETAIL EQUIPMENT

## VEGETABLE STAND S2 WITH REGULATION



Stand is designed for exhibition and sale of fruits and vegetables placed on the boxes. On one rack, you can put 2 boxes.

**Standard finish:** zinc plated + lacquer, optionally: upper frame powder coated.

**Technical data:** Rack made of sections and pipes; castors  $\varnothing 80$  mm. There is a possibility to adjust the tilt of the frame. Rack construction allows to folding a rack to the very small size.

**Maximum loading:** 75 kg.

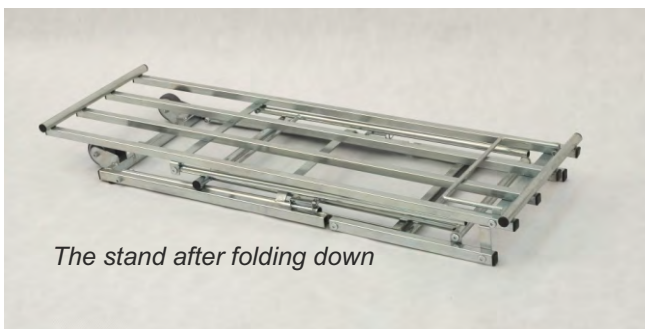

*The stand after folding down*

Size of the folded stand: 1260x415x120 mm.

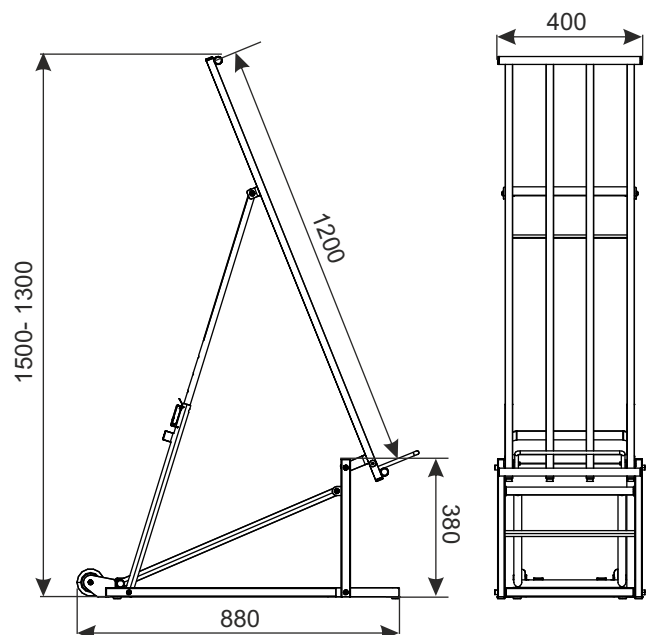

PRODUCT NAME	FINISH	INDEX
Vegetable stand S2 with regulation	zinc plated + lacquer	919-350-940

### E3 SPECIAL RETAIL EQUIPMENT

## VEGETABLE STAND S3 WITH REGULATION

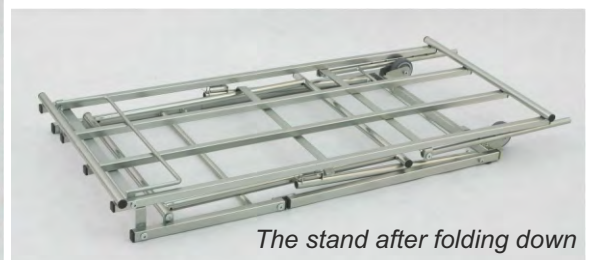

*The stand after folding down*

Stand is designed for exhibition and sale of fruits and vegetables placed on the boxes. On one rack, you can put 3 boxes.

**Standard finish:** zinc plated + lacquer, optionally: upper frame powder coated.

**Technical data:** Rack made of sections and pipes; castors  $\varnothing 80$  mm. There is a possibility to adjust the tilt of the frame. Rack construction allows to folding a rack to the very small size. Size of the folded stand: 1260x615x120 mm.

**Maximum loading:** 100 kg.

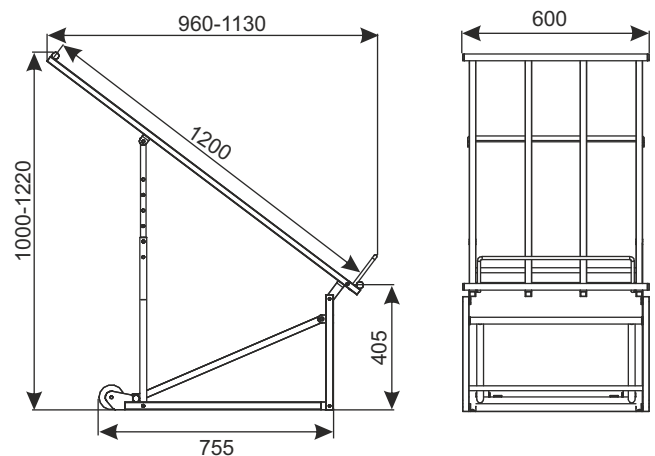

PRODUCT NAME	FINISH	INDEX
Vegetable stand S3 with regulation	zinc plated + lacquer	919-350-905

### E3 SPECIAL RETAIL EQUIPMENT

## STAND FOR CUT FLOWERS



The stand on wheels for cut flowers is made of steel profile, with 3 rims for buckets with flowers.

**Standard finish:** zinc plated or powder painted.

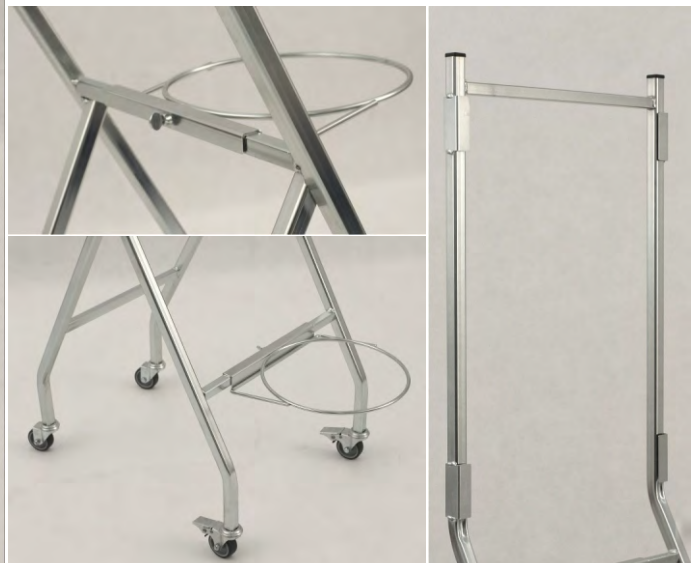
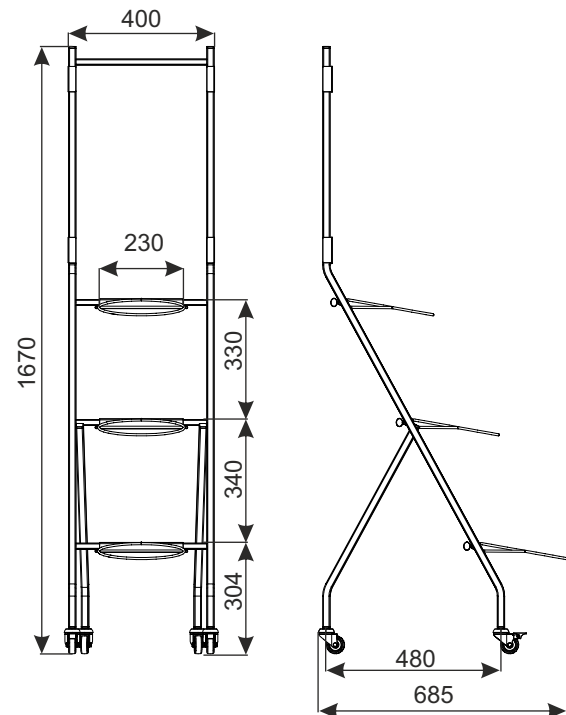

PRODUCT NAME	FINISH	INDEX
Stand for cut flowers	zinc plated + lacquer	919-351-041

### E3 SPECIAL RETAIL EQUIPMENT

DAMIX Sp z o.o. ul. Bohaterów Czerwca 1956r. nr 3; PL - 87-500 Rypin  
 tel. +48 54 280 34 93; fax +48 54 280 45 40; e-mail: damix@damix.pl; handel@damix.pl, www.damix.pl

All rights reserved  
 05 03 2018



## CORNER SHELF FOR FLOWERS

**NEW!**



### Corner shelf for cut and potted flowers:

Frame made of sections, base made of sheet metal with reinforcement from the bottom. Shelves for cut flowers have hoops in which containers with cut flowers are placed. The upper shelf has two container hoops, the lower shelf has three hoops. Rim inner diameter - 244 mm.

### Capacity:

- load capacity of the upper shelf - 20 kg
- load capacity of the lower shelf - 30 kg
- base load capacity - 50 kg

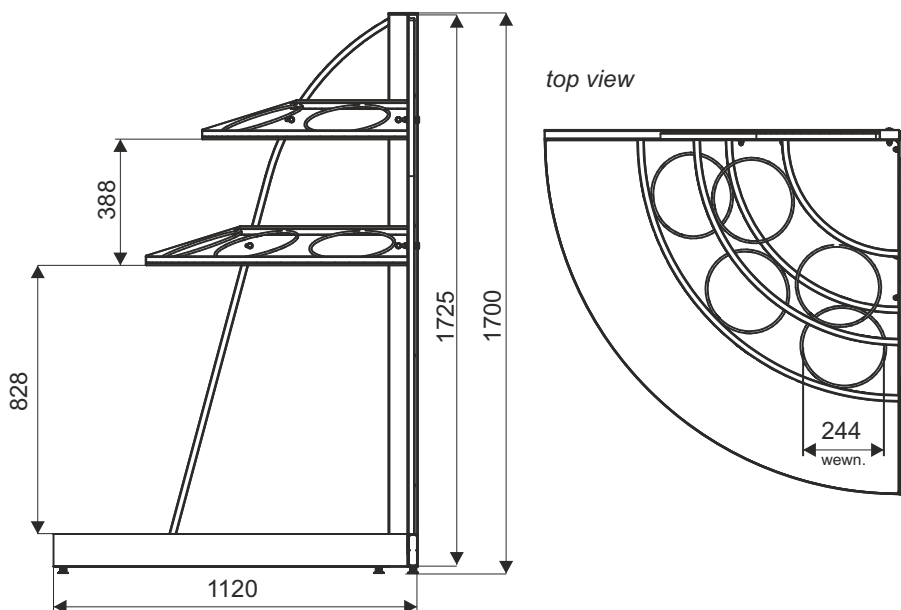

PRODUCT NAME	FINISH	INDEX
Corner shelf for flowers	powder coated	922-346-183

### **E3** SPECIAL RETAIL EQUIPMENT

## 3-SHELF STAND WITH REGULATION

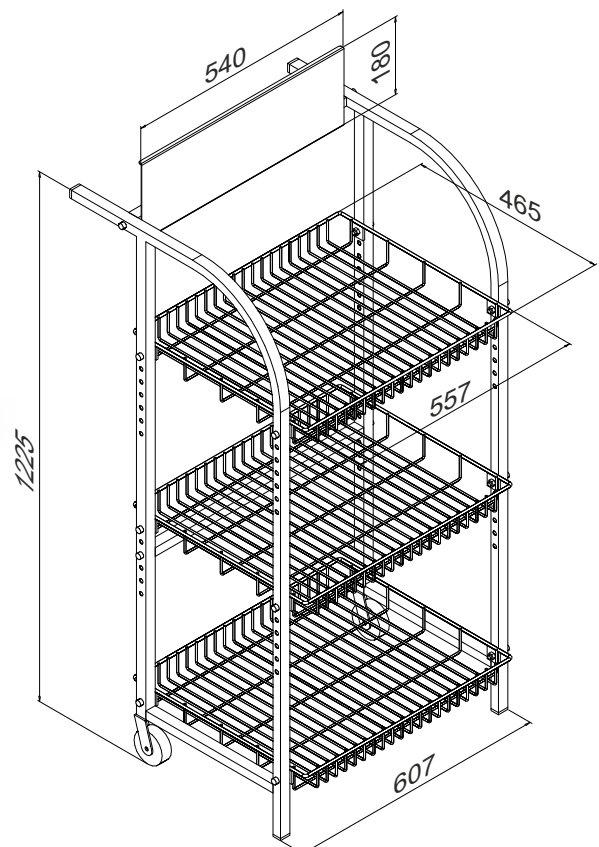
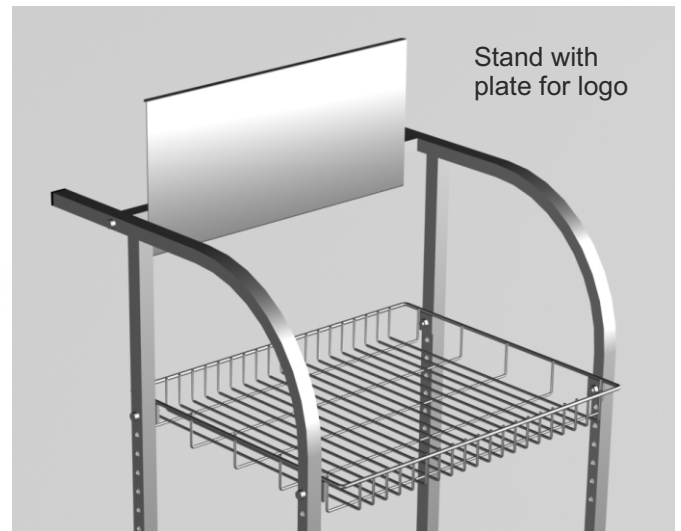

**Standard finish:** powder coated.

**Technical data:** The frame is made of section, wire shelves bolted to the frame, possibility of adjust the height of the shelves on the required level. Two wheels attached to the rear legs make it easy to move the rack.

Plate for logo is optional equipment.

PRODUCT NAME	FINISH	INDEX
3-shelf stand with regulation with plate for logo	powder coated	922-345-504
3-shelf stand with regulation without plate for logo	powder coated	922-345-636

### E3 SPECIAL RETAIL EQUIPMENT

## ROUND BASKET KO 850x600

Basket with base



Basket with cover (option)



Basket with the oblique cover (option)



A big basket on a wire base is intended to rubbish. As the option, it's possible to put wire cover for baskets which protects falling of the rubbish.

**Standard cover:** galvanized zinc + lacquer.  
**Technical data:** basket, base and cover made of wire.

The basket is fixed to the wire base with the usage of metal clamps.

*basket's cover*

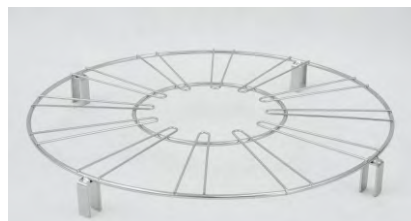

*basket's oblique cover*

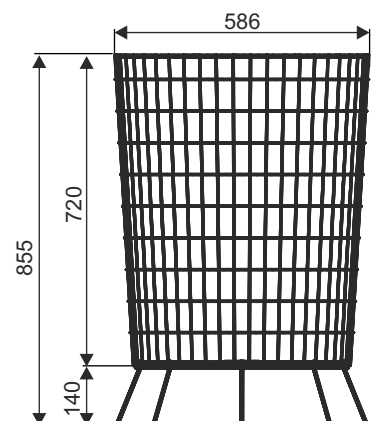
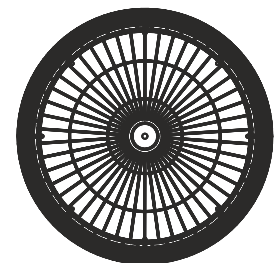
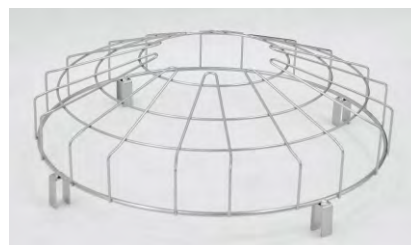

PRODUCT NAME	FINISH	INDEX
Round basket KO 850x600	galvanized zinc + lacquer	919-351-447
Round basket's cover KO-850x600 (option)	galvanized zinc + lacquer	919-351-302
Round basket's oblique cover KO-580x720 (option)	galvanized zinc + lacquer	919-351-451

### E3 SPECIAL RETAIL EQUIPMENT

## STAND FOR WASTE SEGREGATION (FOR 3 SACKS)



In connection with the amendment of the Act on maintaining cleanliness and order in municipalities we meet the needs of municipalities and communes as well as households in the segregation of waste and protect the environment. Stand for waste segregation is a simple and versatile tool for segregate garbage into three basic types.



Light and simple design allows for easy assembly and distribution of the rack.

The way of mounting the garbage sacks with rubber putted on the rim is very quick and simple.

**Standard finish:** zinc plated + lacquer or zinc plated + powder coated (standard colors RAL 7016 and RAL 6005).

**Technical data:** construction made of sections, rims and covers made of metal sheet. The covers are hinged, used elastic rubber band on the rim protects the bag from sliding off the rim. You can fix the stand to the ground.

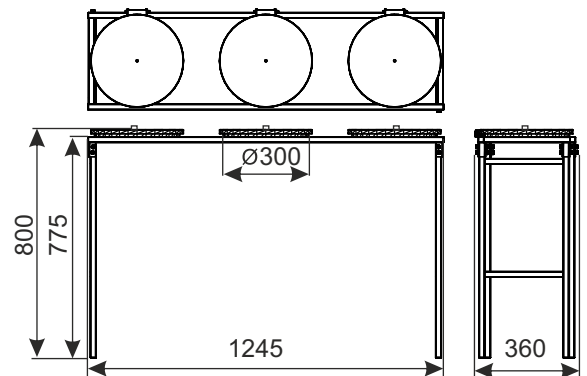

PRODUCT NAME	FINISH	INDEX
Stand for waste segregation (for 3 sacks)	zinc plated + lacquer	919-351-040
Stand for waste segregation (for 3 sacks)	zinc plated + powder coated	919-343-969

### E3 SPECIAL RETAIL EQUIPMENT

## LOCKERS FOR CLIENTS BAGS



Safe for clients bags (8 hiding place),  
Safe for clients bags (10 hiding place)

**Technical data:** The deposit cabinet is available in two options with 8 boxes or 10 boxes.



PRODUCT NAME	FINISH	INDEX
Lockers for clients bags (8 hiding place)	powder coated	SZAFKA_02X04
Lockers for clients bags (10 hiding place)	powder coated	SZAFKA_02X05

### E3 SPECIAL RETAIL EQUIPMENT

## OUTDOOR GONDOLA (for the sale of goods on petrol stations)



This gondola with a rolling shutter and wheels is a presentation device mainly used to display and store materials that are particularly sensitive to external factors. Due to its structure and the use of shelves inside, the gondola can be used to store smaller products, such as those in containers and bottles. This product is particularly dedicated to the petrol stations. Due to its built-in lock, the rolling aluminum shutter ensures the safety of the goods located inside. An additional advantage of the gondola is its wheels, allowing it to be easily moved.

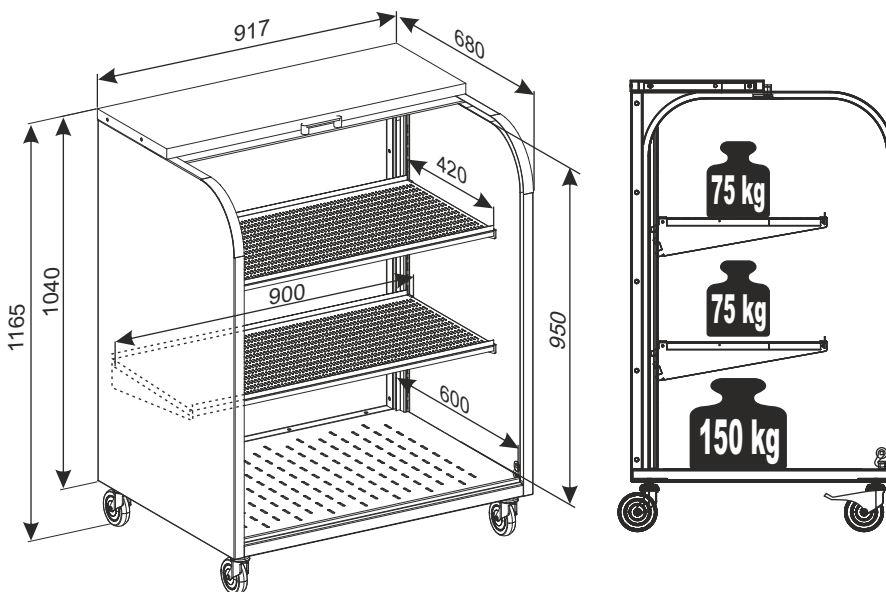

**Standard finish:** electroplated with zinc and next polyester powder coated.

**Technical data:** The gondola is made of metal sheet, sections and flat irons that reinforce its construction. It is equipped with an aluminum rolling shutter that has special plastic sliders, a push button type lock with a set of keys, four brackets, two perforated shelves for displaying of the goods and four polyamide wheels with a diameter of 100 mm (two of the wheels are equipped with breaks).

**Maximum loading:**  
(with equable loading):  
shelf - 75 kg,  
bottom of the gondola - 150 kg.

In the option one can be install anchors for fixing to the ground or regulated feet instead of wheels.

PRODUCT NAME	FINISH	INDEX
Outdoor gondola (for the sale of goods on petrol stations)	electroplated with zinc and next polyester powder coated	922-345-225

### E3 SPECIAL RETAIL EQUIPMENT

## ACCESSORIES FOR COOLING DEVICES

### Applied coatings:

- zinc plated + powder coated,
- polyethylene,
- rilsan.

Examples of project implementation:

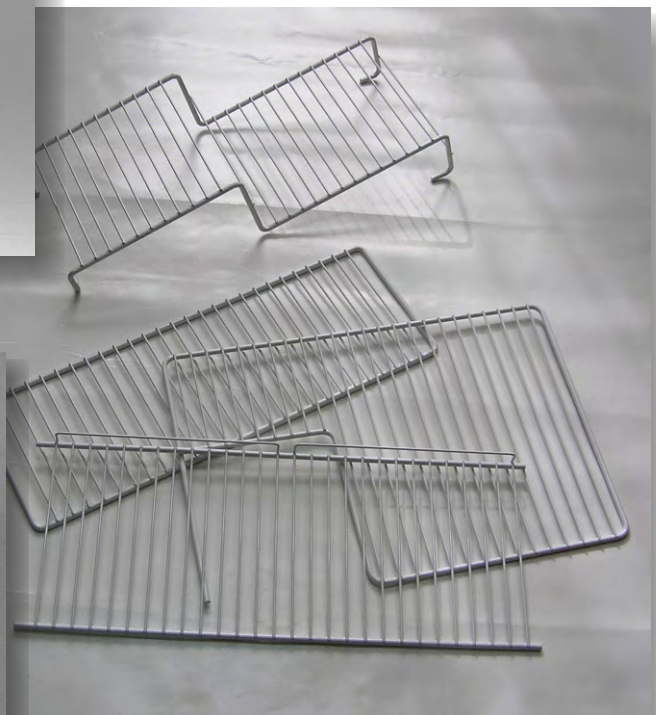
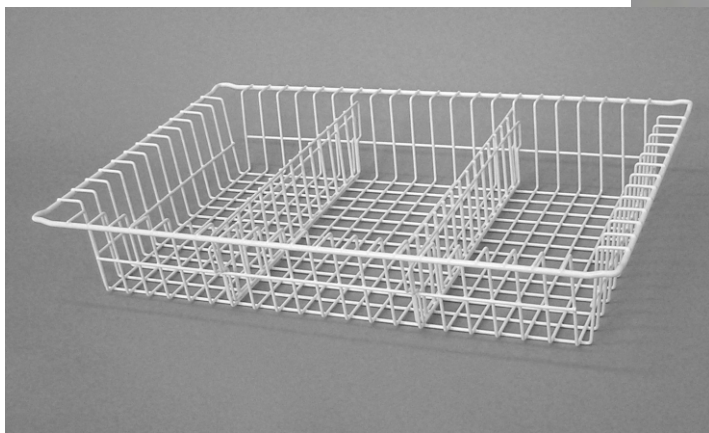
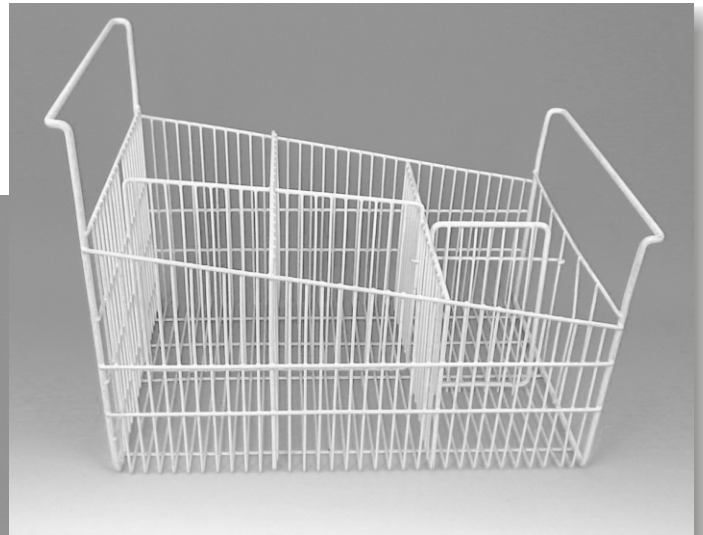
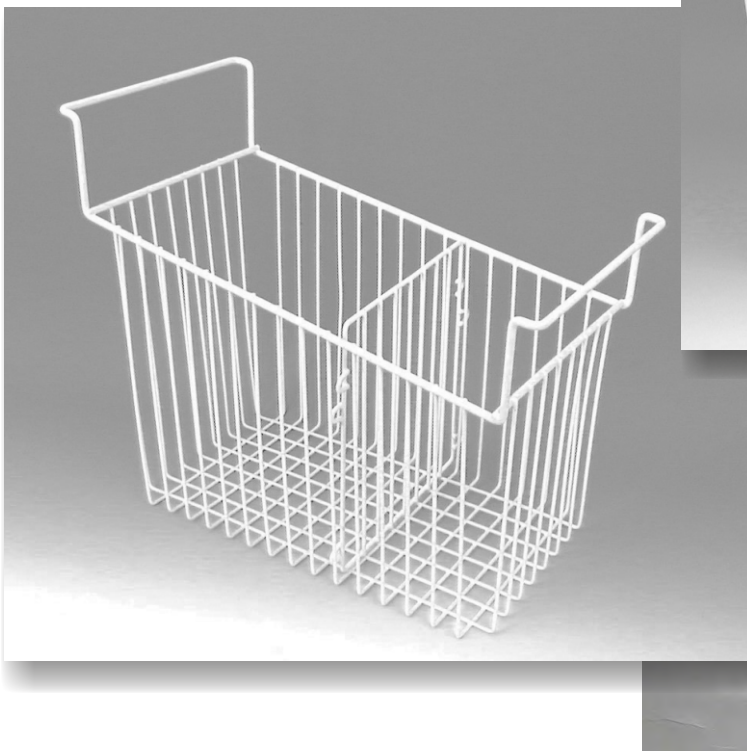

### E3 SPECIAL RETAIL EQUIPMENT



EQUIPMENT FOR SHELVING,  
SHOP SHELVING,  
SHELVING AND EXHIBITION  
STANDS POS & POP,  
HOOKS AND BARRIERS FOR SHELVING





## **E4** EQUIPMENT FOR SHELVING, SHOP SHELVING

- 1 Stacking basket
- 2 Folding stacking basket KSD
- 3 Folding stacking basket KSC
- 4 Folding stacking basket KSC II
- 5 Folding stacking basket STKK
- 6 Stacking basket PG
- 7 Stacking basket PP
- 8 Shelving baskets BFR
- 9 Shelving baskets KR
- 10 Shelving above freezer
- 11 Shelving for fruit and vegetable's stand
- 12 Mobile shelving 1310x900x1600 with 6 shelves
- 13 A mobile stand for small non-food 1310x880x1600
- 14 Stainless steel rack 900x500 H1800 with four shelves
- 15 Front stop for shelving H-80 (openwork 24,3)
- 16 Front stop for shelving H-60 (openwork 24,3)
- 17 Transverse partitions
- 18 Hooks
- 19 Shelving and exhibition stands POP & POS

*The reproduce without prior permission is forbidden. In order to improve, the manufacturer reserves the right to implement modifications in its products. Recommendations for installation and use the products are provided for informational purposes only and does not imply any liability on the part of the manufacturer.*

## **E4** EQUIPMENT FOR SHELVING, SHOP SHELVING

## STACKING BASKETS

Example of application

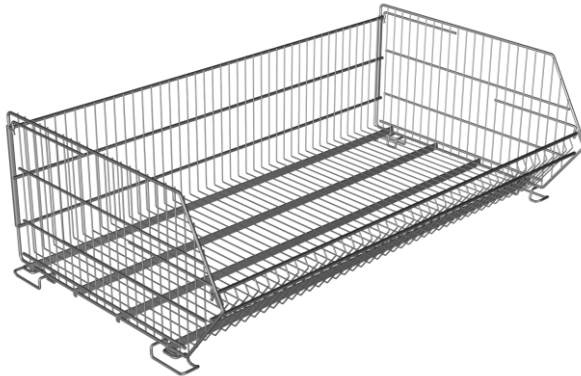

**Standard finish:** zinc plated + lacquer or powder coated.

**Technical data:** The structure of basket made of spot welded wire. The bottom is reinforced with flat irons against deformation. Stacking feet made of wire. The movable chassis made of sections.

**Maximum loading:**

(with equable spreading of the goods): single basket - 100 kg,  
3 stacked baskets - 100kg/50kg/50 kg.

Baskets are mainly intended for storage and loose display of fast-rotating goods in stores and supermarkets.

**Possible use of baskets:**

- setting on the racks shelf,
- placed directly on the ground,
- stacking baskets one on another,
- assembly on the movable chassis.

TYPE OF THE BASKET	DIMENSIONS (mm)				
	a	b	c	d	e
600x400 H-365	600	440	365	400	560
600x600 H-365	600	640	365	400	560
800x500 H-365	800	540	365	400	765
1200x500 H-365	1200	540	365	400	1165
1200x600 H-365	1200	640	365	400	1160
1200x700 H-365	1230	700	365	400	1190
1300x800 H-390	1335	800	390	420	1295

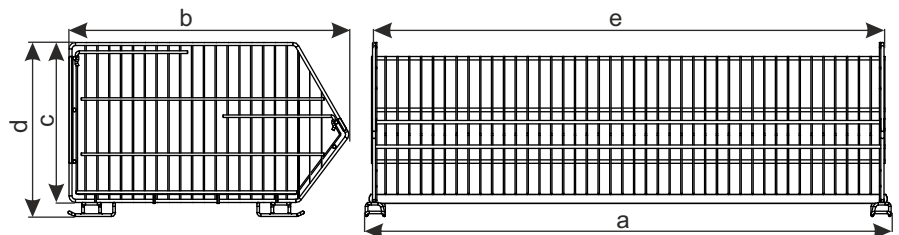

**ADDITIONAL ACCESORIES:**

Aesthetic wire divider can be used to divide the basket at any location, allowing a larger number of different products to be displayed. Base with wheels makes the baskets become an independent movable rack.

**Movable chassis to the stacking basket**



**Divider to the basket**

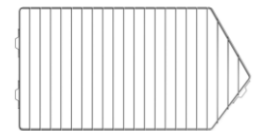

PRODUCT NAME	FINISH	INDEX	FINISH	INDEX
Stacking basket 600x400 H-365	powder coated	919-343-840	zinc plated + lacquer	_____
Stacking basket 600x600 H-365	powder coated	919-343-026	zinc plated + lacquer	_____
Stacking basket 800x500 H-365	powder coated	919-344-001	zinc plated + lacquer	_____
Stacking basket 1200x500 H-365	powder coated	919-343-917	zinc plated + lacquer	_____
Stacking basket 1200x600 H-365	powder coated	919-342-994	zinc plated + lacquer	919-350-741
Stacking basket 1200x700 H-365	powder coated	919-343-028	zinc plated + lacquer	919-350-742
Stacking basket 1300x800 H-390	powder coated	919-343-030	zinc plated + lacquer	_____
ADDITIONAL EQUIPMENT	FINISH	INDEX	FINISH	INDEX
Divider to the basket 400 H-310	powder coated	919-343-841	zinc plated + lacquer	_____
Divider to the basket 500 H-310	powder coated	919-343-918	zinc plated + lacquer	_____
Divider to the basket 600 H-310	powder coated	919-342-995	zinc plated + lacquer	919-350-779
Divider to the basket 700 H-310	powder coated	919-343-029	zinc plated + lacquer	919-350-743
Divider to the basket 800 H-265	powder coated	919-343-031	zinc plated + lacquer	_____
Movable chassis to the stacking basket 600x400	powder coated	919-343-842	zinc plated + lacquer	_____
Movable chassis to the stacking basket 600x600	powder coated	919-343-027	zinc plated + lacquer	_____
Movable chassis to the stacking basket 1200x600	powder coated	919-342-996	zinc plated + lacquer	919-350-784

**E4 EQUIPMENT FOR SHELVING, SHOP SHELVING**

## FOLDING STACKING BASKETS KSD (wire stacking feet)



Baskets are mainly intended for storage and loose display of fast-rotating goods in stores and supermarkets.

**Possible use of baskets:**

- setting on the racks shelf
- separate placed on the ground
- stacking baskets one on another
- assembly on the movable chassis

Its small dimensions after folding means that when a basket is not being used, it doesn't take up warehouse space.

**Standard finish:** zinc plated + lacquer .

**Technical data:** The structure of basket made of spot welded wire. The bottom is reinforced with flat irons against deformation under heavy loads. The movable chassis made of sections.

**Maximum loading:**

(with equable spreading of the goods):  
single basket - 100 kg,  
3 stacked baskets - 100kg/50kg/50 kg.

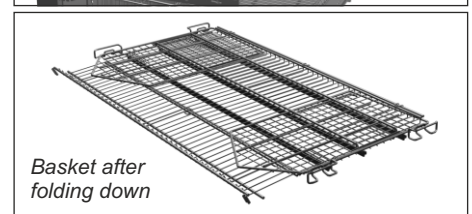
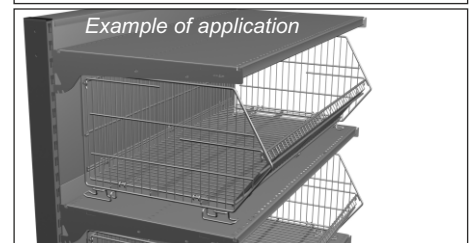

TYPE OF THE BASKET	DIMENSIONS (mm)				
	Basket				
	a	b	c	d	e
1210X670 H-400	1240	670	385	420	1205
600x640 H-400	600	620	365	400	560

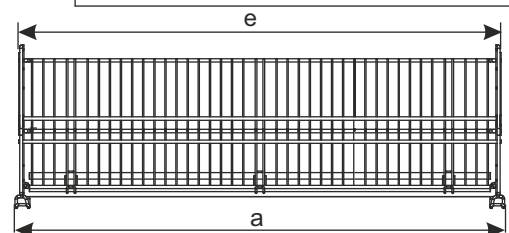
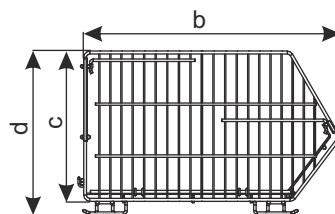

**ADDITIONAL ACCESORIES:**

Aesthetic wire divider can be used to divide the basket at any location, allowing a larger number of different products to be displayed. Base with wheels makes the baskets become an independent movable rack.

**Movable chassis to the stacking basket**



**Divider to the basket**

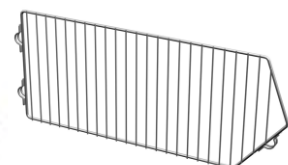

PRODUCT NAME	FINISH	INDEX
Folding stacking basket KSD 600x640 H-400	zinc plated + lacquer	919-350- 906
Folding stacking basket KSD 1210x670 H-400	zinc plated + lacquer	919-350-935
ADDITIONAL EQUIPMENT	FINISH	INDEX
Divider to folding stacking basket KSD 670 H-270	zinc plated + lacquer	919-350-788
Movable chassis to the folding stacking basket KSD 1210x670	zinc plated + lacquer	919-350-933

**E4 EQUIPMENT FOR SHELVING, SHOP SHELVING**

## FOLDING STACKING BASKETS KSC (stacking feet made of channel bar)

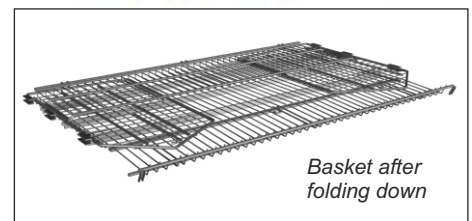
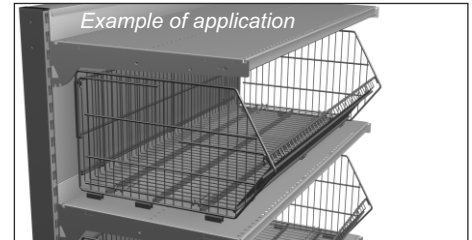
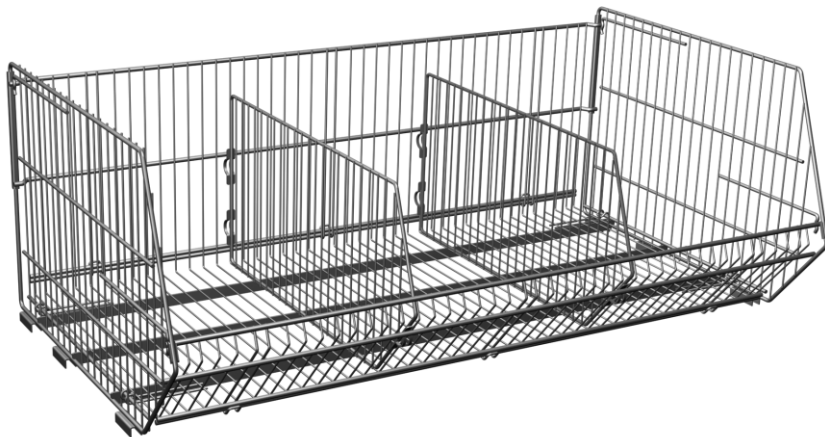

Baskets are mainly intended for storage and loose display of fast-rotating goods in stores and supermarkets.

### Possible use of baskets:

- setting on the racks shelf
- assembly on the pallet box 1200x800

Its small dimensions after folding means that when a basket is not being used, it doesn't take up warehouse space.

**Standard finish:** zinc plated + lacquer .

**Technical data:** The structure of basket made of spot welded wire. The bottom is reinforced with flat irons against deformation under heavy loads. Stacking feet made of channels bar.

**Maximum loading:** (with equable spreading of the goods): 100 kg

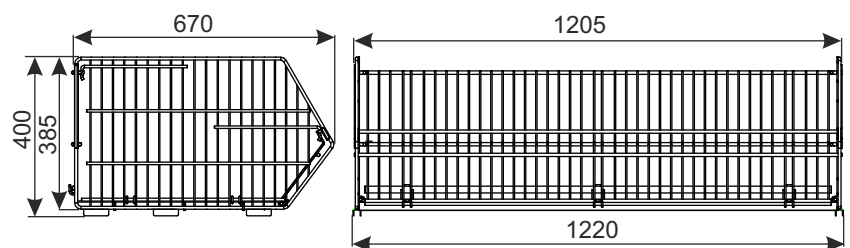

### ADDITIONAL ACCESORIES:

Aesthetic wire divider can be used to divide the basket at any location, allowing a larger number of different products to be displayed.



Divider to the basket

PRODUCT NAME	FINISH	INDEX
Folding stacking basket KSC 1210x670 H-400	zinc plated + lacquer	919-350-787
ADDITIONAL EQUIPMENT	FINISH	INDEX
Divider to folding stacking basket 670 H-270	zinc plated + lacquer	919-350-788

## E4 EQUIPMENT FOR SHELVING, SHOP SHELVING

## FOLDING STACKING BASKETS KSC II (stacking feet made of channel bar)



Basket after folding down

Baskets are mainly intended for storage and loose display of fast-rotating goods in stores and supermarkets.

**Possible use of baskets:**

- setting on the racks shelf
- separate placed on the ground
- stacking baskets one on another
- assembly on the movable chassis (only basket 1210x670)

Its small dimensions after folding means that when a basket is not being used, it doesn't take up warehouse space.

**Standard finish:** zinc plated + lacquer .

**Technical data:** The structure of basket made of spot welded wire. The bottom is reinforced with flat irons against deformation under heavy loads. Stacking feet made of channels bar. The movable chassis made of sections.

**Maximum loading:**

(with equable spreading of the goods):

single basket - 100 kg,

3 stacked baskets - 100kg/50kg/50 kg.

TYPE OF THE BASKET	DIMENSIONS (mm)				
	Basket				
	a	b	c	d	e
1210X670 H-400	1205	670	385	400	1217
1210X570 H-400	1205	570	385	400	1217
1210X470 H-400	1205	470	385	400	1217
1210X370 H-400	1205	370	385	400	1217

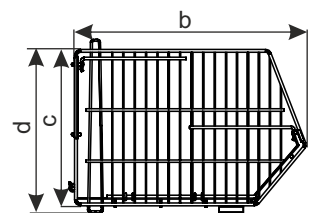
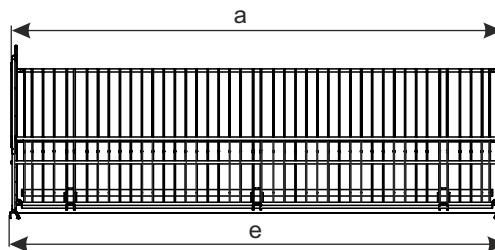

**ADDITIONAL ACCESORIES:**

Aesthetic wire divider can be used to divide the basket at any location, allowing a larger number of different products to be displayed. Base with wheels makes the baskets 1210x670 become an independent movable rack.

PRODUCT NAME	FINISH	INDEX
Folding stacking basket 1210x670 H-400	zinc plated + lacquer	919-351-100
Folding stacking basket 1210x570 H-400	zinc plated + lacquer	919-351-101
Folding stacking basket 1210x470 H-400	zinc plated + lacquer	919-351-102
Folding stacking basket 1210x370 H-400	zinc plated + lacquer	919-351-103

ADDITIONAL EQUIPMENT	FINISH	INDEX
Divider H270 to folding stacking basket 670x400	zinc plated + lacquer	919-350-788
Divider H270 to folding stacking basket 570x400	zinc plated + lacquer	919-351-104
Divider H270 to folding stacking basket 470x400	zinc plated + lacquer	919-351-105
Divider H270 to folding stacking basket 370x400	zinc plated + lacquer	919-351-106
Base with wheels to folding stacking basket 1200x670	zinc plated + lacquer	919-351-107

### E4 EQUIPMENT FOR SHELVING, SHOP SHELVING

## FOLDING STACKING BASKETS STKK (stacking feet made of closed channel bar)

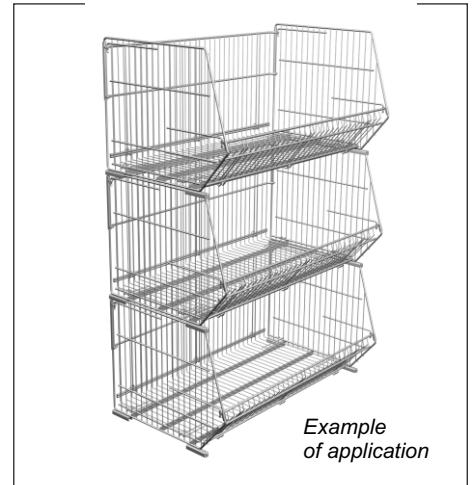
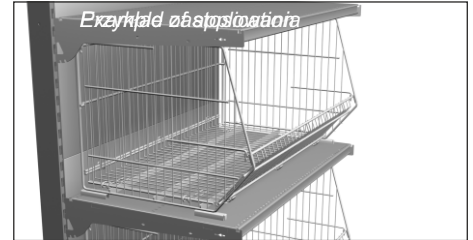

Baskets are mainly intended for storage and loose display of fast-rotating goods In stores and supermarkets.

**Possible use of baskets:**

- setting on the racks shelf
- stacking baskets one on another

Its small dimensions after folding means that when a basket is not being used, it doesn't take up warehouse space.

**Standard finish:** zinc plated + lacquer .

**Technical data:** The structure of basket made of spot welded wire. The bottom is reinforced with flat irons against deformation under heavy loads. Stacking feet made of channel bar with closed ends to protect against displacement of stacked baskets.

**Maximum loading:**

(with equable spreading of the goods):  
single basket - 100 kg,  
3 stacked baskets - 100kg/50kg/50 kg.

TYPE OF THE BASKET	DIMENSIONS (mm)				
	Basket				
	a	b	c	d	e
940x680 H-435	955	600	435	455	940
940x580 H-450	955	580	470	490	940
500x580 H-450	515	580	470	490	500

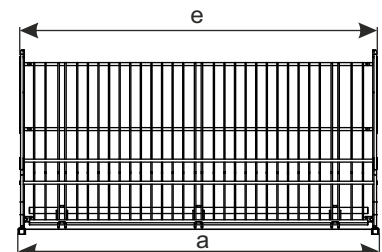
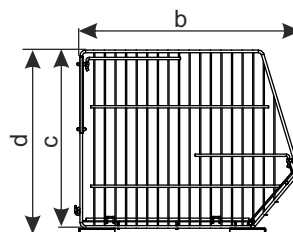

PRODUCT NAME	FINISH	INDEX
Folding stacking basket STKK 940x680 H-435	zinc plated + lacquer	919-343-812
Folding stacking basket STKK 940x580 H-450	zinc plated + lacquer	919-350-856
Folding stacking basket STKK 500x580 H-450	zinc plated + lacquer	919-350-920

### E4 EQUIPMENT FOR SHELVING, SHOP SHELVING

## STACKING BASKETS PG

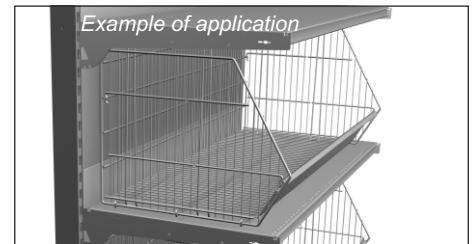
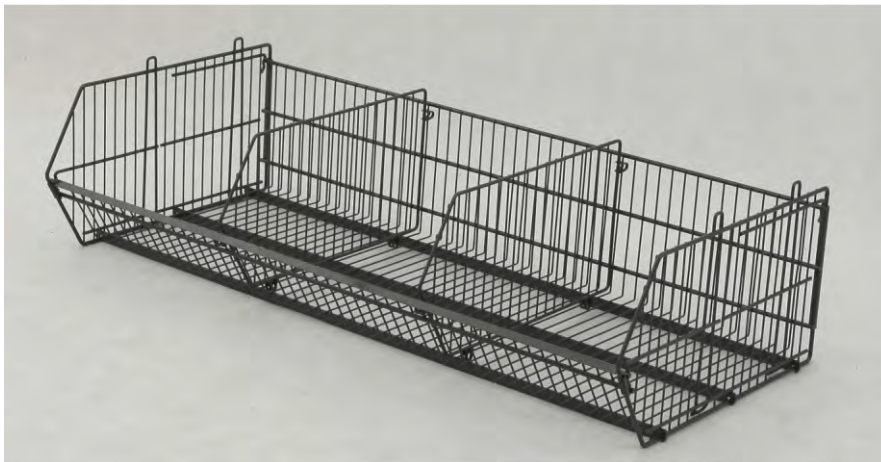

Possible use of baskets: setting on the racks shelf, stacking baskets one on another, assembly on the movable chassis to the PG baskets.

**Standard finish:** zinc plated + lacquer or powder coated.

**Technical data:** The structure of basket made of spot welded wire. The bottom is reinforced with flat irons

**Maximum loading:**

(with equable spreading of the goods):

single basket - 100 kg,

3 stacked baskets - 100kg/50kg/50 kg.

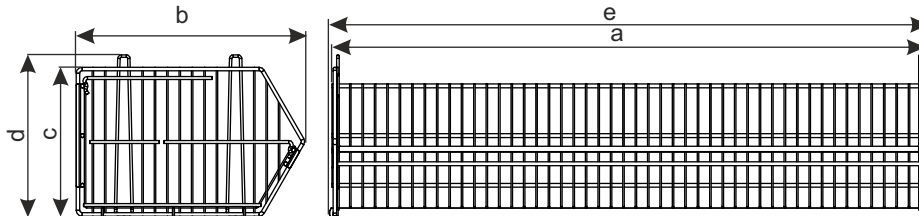

TYPE OF THE BASKET	DIMENSIONS (mm)				
	Basket				
	a	b	c	d	e
1195x460 H-300	1195	460	300	325	1206
1195x570 H-450	1195	570	450	475	1206
1220x570 H-300	1220	570	300	325	1206
1310x460 H-300	1295	460	300	325	1306
1310x570 H-300	1295	570	300	325	1306
1310x570 H-450	1295	570	450	475	1306
1310x910 H-300	1295	910	300	325	1306
1310x910 H-450	1295	910	450	475	1306

### ADDITIONAL ACCESSORIES:

Aesthetic wire divider can be used to divide the basket at any location, allowing a larger number of different products to be displayed. Base makes the baskets become an independent rack.

PRODUCT NAME	FINISH	INDEX	FINISH	INDEX
Stacking basket PG 1195x460 H-300	zinc plated + lacquer	————	powder coated	919-343-874
Stacking basket PG 1195x570 H-450	zinc plated + lacquer	————	powder coated	919-343-875
Stacking basket PG 1220x570 H-300	zinc plated + lacquer	————	powder coated	919-343-847
Stacking basket PG 1310x460 H-300	zinc plated + lacquer	919-350-925	powder coated	————
Stacking basket PG 1310x570 H-300	zinc plated + lacquer	————	powder coated	919-343-878
Stacking basket PG 1310x570 H-450	zinc plated + lacquer	919-350-926	powder coated	919-343-877
Stacking basket PG 1310x910 H-300	zinc plated + lacquer	————	powder coated	919-343-848
Stacking basket PG 1310x910 H-450	zinc plated + lacquer	————	powder coated	919-343-849
ADDITIONAL EQUIPMENT	FINISH	INDEX	FINISH	INDEX
Divider to stacking basket PG 460 H-300	zinc plated + lacquer	————	powder coated	919-343-879
Divider to stacking basket PG 570 H-300	zinc plated + lacquer	————	powder coated	919-343-856
Divider to stacking basket PG 570 H-450	zinc plated + lacquer	————	powder coated	919-343-880
Divider to stacking basket PG 910 H-300	zinc plated + lacquer	————	powder coated	919-343-857
Divider to stacking basket PG 910 H-450	zinc plated + lacquer	————	powder coated	919-343-858
Base to the stacking basket PG 1195x570	zinc plated + lacquer	————	powder coated	919-343-882

### E4 EQUIPMENT FOR SHELVING, SHOP SHELVING

## STACKING BASKETS PP

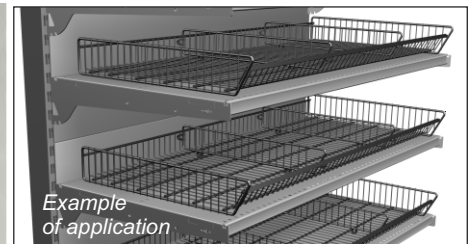
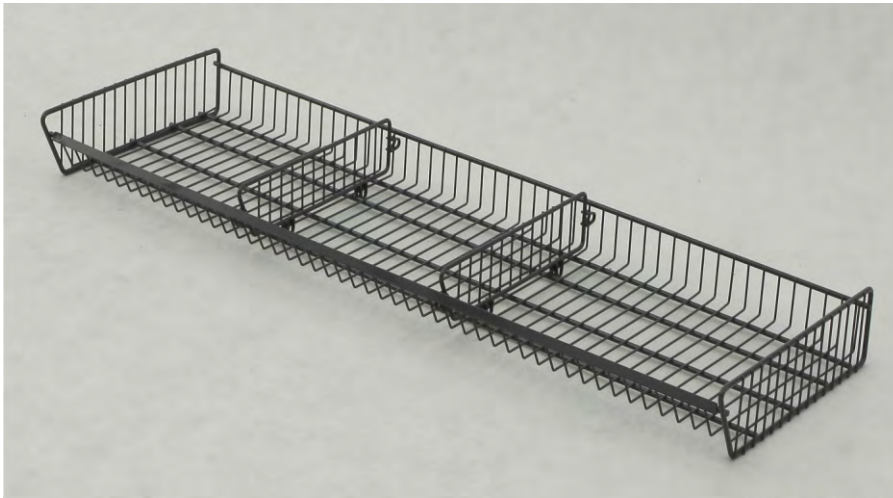

### Possible use of baskets:

- setting on the racks shelf,
- assembly on the movable chassis to the PG baskets.

**Standard finish:** powder coated or optionally zinc plated + lacquer .

**Technical data:** The structure of basket made of spot welded wire.

### Maximum loading:

(with equable spreading of the goods): 50 kg

TYPE OF THE BASKET	DIMENSIONS (mm)		
	Basket		
	a	b	c
1195x460 H-100	1195	460	100
1220x410 H-100	1220	410	100
1220x570 H-100	1220	570	100
1310x570 H-100	1295	570	100
1310x910 H-100	1295	910	100

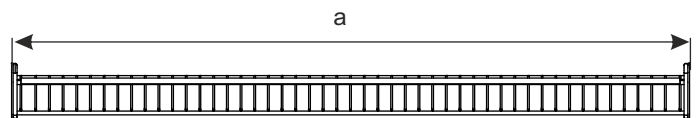

### ADDITIONAL ACCESORIES:

Aesthetic wire divider can be used to divide the basket at any location, allowing a larger number of different products to be displayed.

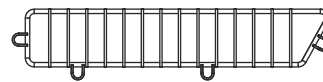

PRODUCT NAME	FINISH	INDEX
Stacking basket PP 1195x460 H-100	powder coated	919-343-860
Stacking basket PP 1220x410 H-100	powder coated	919-343-850
Stacking basket PP 1220x570 H-100	powder coated	919-343-851
Stacking basket PP 1310x570 H-100	powder coated	919-343-861
Stacking basket PP 1310x910 H-100	powder coated	919-343-852
ADDITIONAL EQUIPMENT	FINISH	INDEX
Divider to stacking basket PP 410 H-100	powder coated	919-343-853
Divider to stacking basket PP 460 H-100	powder coated	919-343-883
Divider to stacking basket PP 570 H-100	powder coated	919-343-854
Divider to stacking basket PP 910 H-100	powder coated	919-343-855

## E4 EQUIPMENT FOR SHELVING, SHOP SHELVING



## SHELVING BASKETS BFR

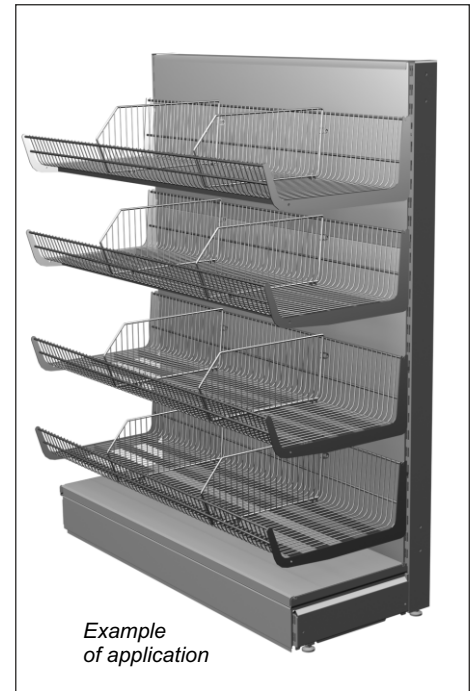

The hook-in baskets to the racks are used to display and sell various goods.

**Standard finish:** powder coated or optionally zinc plated + lacquer .  
**Technical data:** The structure of basket made of spot welded wire. The bottom is reinforced with flat bars, sides made of metal sheet enable to hook-in the shelf to the rack. Divider made of spot welded wire  
**Maximum loading:**  
 (with equable spreading of the goods): 100 kg.

TYPE OF THE BASKET	DIMENSIONS (mm)				
	a	b	c	d	e
BFR 1250x460	1250	460	190	225	522
BFR 1250x560	1250	560	190	225	622

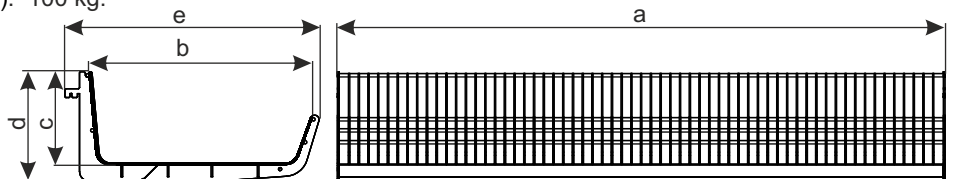

### ADDITIONAL ACCESORIES:

Aesthetic wire divider can be used to divide the basket at any location, allowing a larger number of different products to be displayed.

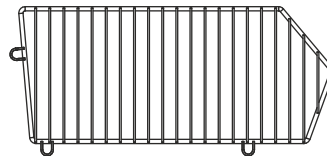

PRODUCT NAME	FINISH	INDEX
Shelving basket BFR 1250x460	powder coated	919-343-831
Shelving basket BFR 1250x560	powder coated	919-343-832
ADDITIONAL EQUIPMENT	FINISH	INDEX
Divider to shelving basket BFR T460	powder coated	919-343-833
Divider to shelving basket BFR T560	powder coated	919-343-834

## E4 EQUIPMENT FOR SHELVING, SHOP SHELVING

## SHELVING BASKETS KR

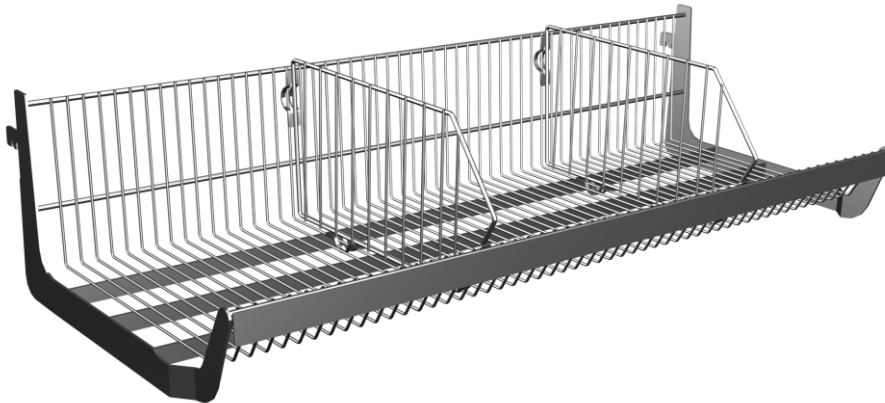

The hook-in baskets to the racks is used to display and sell various goods.

**Standard finish:** zinc plated + lacquer .

**Technical data:** The structure of basket made of spot welded wire. The bottom is reinforced with flat bars, sides made of metal sheet enable to hook-in the shelf to the rack. Divider made of spot welded wire

**Maximum loading:**  
(with equable spreading of the goods): 100 kg.



TYPE OF THE BASKET	DIMENSIONS (mm)				
	a	b	c	d	e
KR 1000x370	1000	370	182	228	430
KR 1000x470	1000	470	182	228	530
KR 1000x570	1000	570	182	228	630
KR 1250x370	1250	370	182	228	430
KR 1250x470	1250	470	182	228	530
KR 1250x570	1250	570	182	228	630
KR 1330x470	1327	470	182	228	530

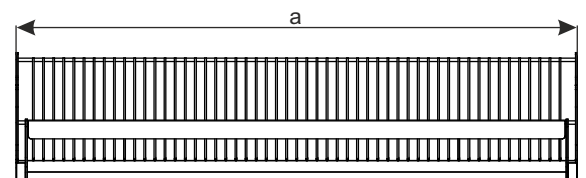
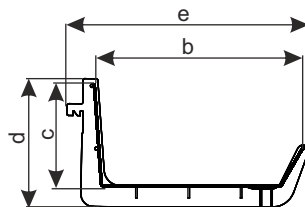

### ADDITIONAL ACCESORIES:

Aesthetic wire divider can be used to divide the basket at any location, allowing a larger number of different products to be displayed.

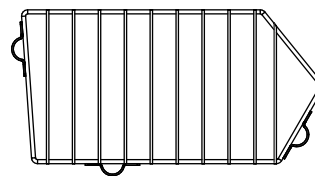

PRODUCT NAME	FINISH	INDEX
Shelving basket KR 1000x370	zinc plated + lacquer	919-350-911
Shelving basket KR 1000x470	zinc plated + lacquer	919-350-838
Shelving basket KR 1000x570	zinc plated + lacquer	919-350-837
Shelving basket KR 1250x370	zinc plated + lacquer	919-350-912
Shelving basket KR 1250x470	zinc plated + lacquer	919-350-836
Shelving basket KR 1250x570	zinc plated + lacquer	919-350-835
Shelving basket KR 1330x470	zinc plated + lacquer	919-351-488
ADDITIONAL EQUIPMENT	FINISH	INDEX
Divider to shelving basket KR 370	zinc plated + lacquer	919-350-913
Divider to shelving basket KR 470	zinc plated + lacquer	919-350-840
Divider to shelving basket KR 570	zinc plated + lacquer	919-350-839

### E4 EQUIPMENT FOR SHELVING, SHOP SHELVING

## SHELVING ABOVE FREEZER



Shelving allow to use place above freezers to exposition and sale goods.

**Standard finish:** powder coated, zinc plated feet to the shelving.

**Technical data:** Legs made of section; metal shelves are assembled on brackets stacked into profiles. Whole is powder coated.

**Maximum loading:**

(with equable spreading of the goods)

- total load capacity of the rack - 240 kg
- load capacity of one side of the rack - 120 kg
- load capacity of one shelf - 120 kg

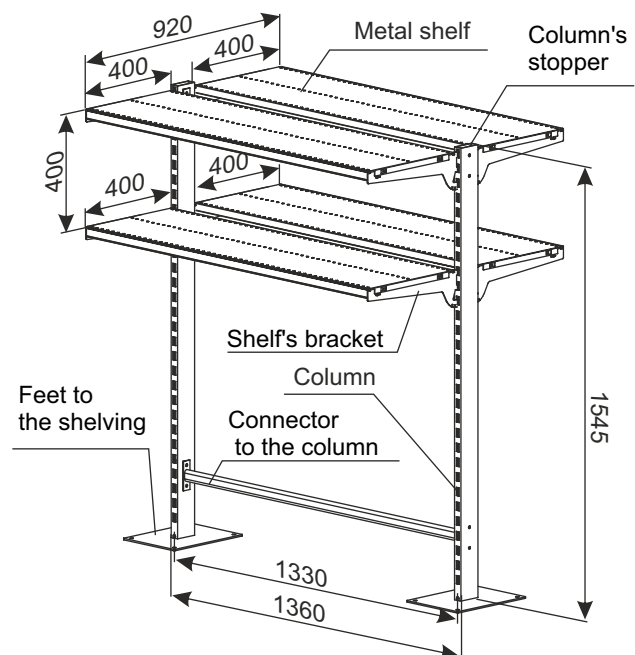

SHELVING ABOVE FREEZER - elements	FINISH	INDEX
Column 80x30x2,5 mm, H-1540 mm	powder coated	922-345-271
Column's stopper 80x30 mm	—	WKPP 80x30
Steel, zinc plated feet to the shelving	zinc plated + lacquer	919-350x680
Connector to the column L-1330	powder coated	922-345-274
Metal shelf 1330x400 assembled on the brackets	powder coated	—
Shelf's bracket T-400	powder coated	922-345-277

### E4 EQUIPMENT FOR SHELVING, SHOP SHELVING

## SHELVING FOR FRUIT AND VEGETABLE'S STAND



Shelving can be used to exposition and sale fruits and vegetables.

**Standard finish:** powder coated; shelves and feet are zinc plated + lacquer.

**Technical data:** legs made of section, wire shelves assembled on brackets, that are stacked into profile. Shelving is assembled to the ground with chemical anchor.

**Maximum loading:**

- (with equable spreading of the goods)
- total load capacity of the rack - 240 kg
  - load capacity of one side of the rack - 120 kg
  - load capacity of one shelf - 120 kg

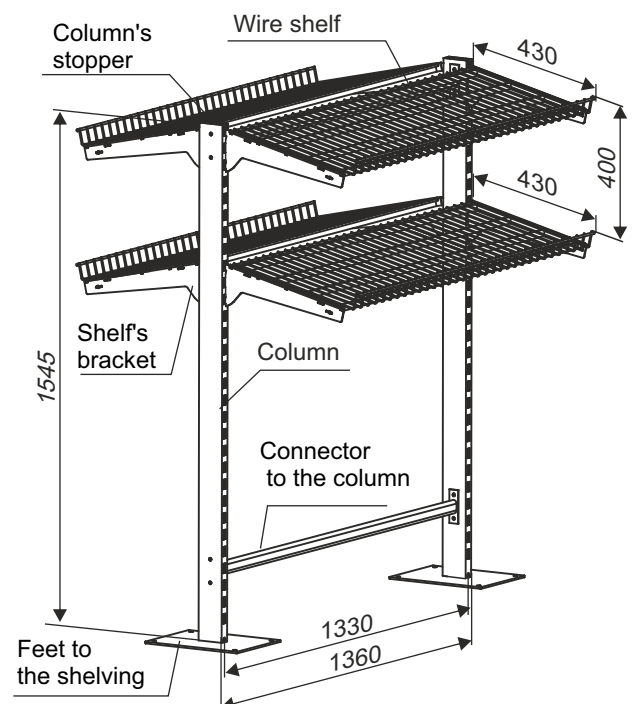

One or two levels of shelves

### ADDITIONAL EQUIPMENT:

**There is a possibility of assembly an additional equipment:**

- Table under the scale,
- Double basket for bags on roll.

SHELVING FOR FRUIT AND VEGETABLE'S STAND - elements	FINISH	INDEX
Column 80x30x2,5 mm, H-1540 mm	powder coated	922-345-271
Column's stopper 80x30 mm	—	WKPP 80x30
Steel, zinc plated feet to the shelving	zinc plated + lacquer	919-350x680
Connector to the column L-1330	powder coated	922-345-274
Wire shelf 1330x430 assembled on the brackets	powder coated	919-342-926
Shelf's bracket T- 400	powder coated	922-345-277

## E4 EQUIPMENT FOR SHELVING, SHOP SHELVING

## MOBILE SHELVING 1310X900X1600 WITH 6 SHELVES



Mobile shelving can be used for exposition and sale of goods. Special construction enables using different combination of placing shelves, including the possibility of adjustment angle and height of mounting shelf as well as raising lower shelf. Castors enable of easy moving. Mobile shelving can be used in stores, warehouses, petrol stations.

**Finish:** zinc plated + lacquer.

**Technical data:**

- Construction made of sections and bars
- Lower shelf: made of wire, reinforced with flat iron, folding
- Upper shelf: made of wire, reinforced with flat iron, assembled to the rack with catch; length 466 mm; 2 shelves on one level, normally three levels are assembly on rack (6 shelves).
- Swivel castors: Ø75 mm with brake; 4 pc.

**Maximum loading:**

static loading of the shelving – 420 kg  
dynamic loading of the shelving – 240 kg  
loading of the bottom shelf – 240 kg  
loading of one level of shelves – 80 kg

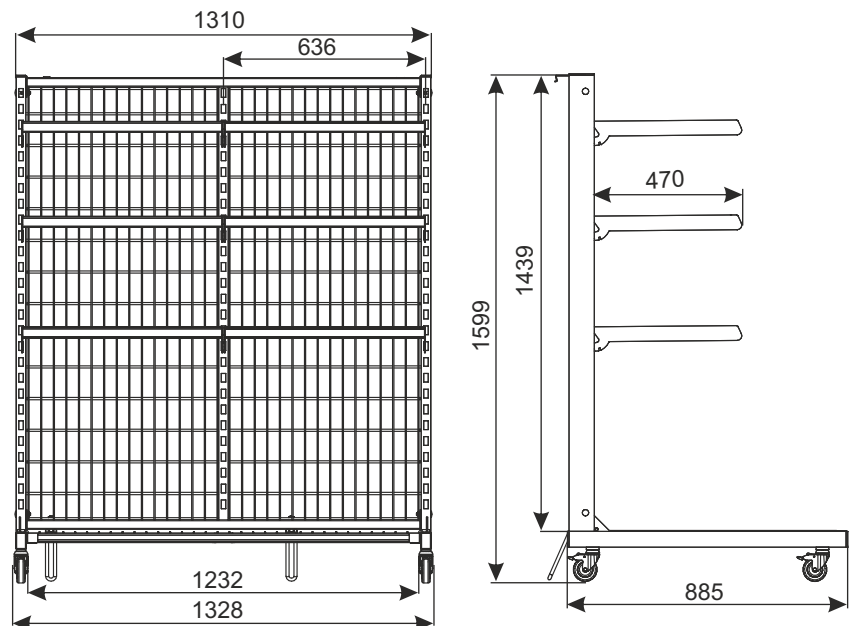

PRODUCT NAME	FINISH	INDEX
Mobile shelvig 1310x900x1600 with 6 shelves zinc plated	zinc plated + lacquer	922-350-009
Mobile shelvig 1310x900x1600 with 6 shelves zinc plated	powder coated RAL 7016	922-350-009_V2

### E4 EQUIPMENT FOR SHELVING, SHOP SHELVING

## A MOBILE STAND FOR SMALL NON-FOOD 1310X880X1600



**Standard finish:** zinc plated.

**Technical data:** Legs of sections, back wall of wire mesh: basket and shelf of wire reinforced by flats, basket hanged up in perforation leg frame, a bottom shelf fixed on foot frame. A possibility of adjust the angle of inclination of hanging basket.

**Loading:**

Total loading of stand - 200 kg.

Loading of hanged up basket - 50 kg.

Loading of bottom shelf - 100 kg.

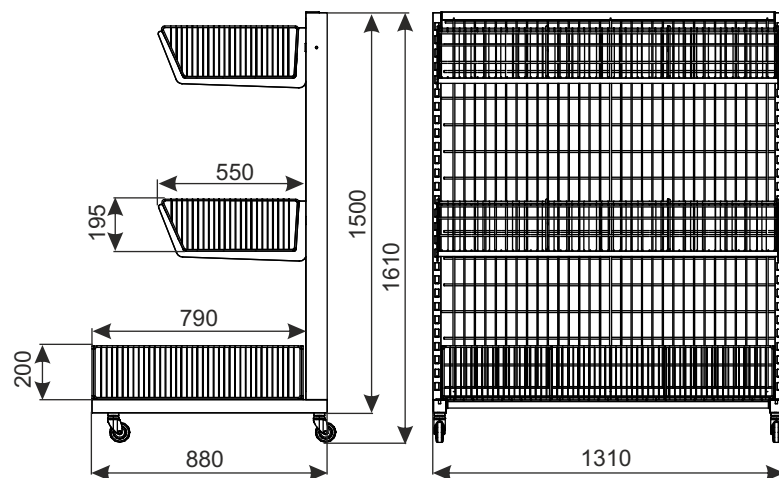

PRODUCT NAME	FINISH	INDEX
A mobile stand for small non-food 1310x880x1600	zinc plated	922-350-019

### E4 EQUIPMENT FOR SHELVING, SHOP SHELVING

## STAINLESS STEEL RACK 900X500 H1800 WITH FOUR SHELVES



The rack can be used in freezers.

**Standard finish:**  
stainless steel

**Technical data:**  
- the construction made of section,  
4 metal shelves with perforation.

**Maximum loading:**  
- loading of shelf - 50 kg  
- total loading - 200 kg

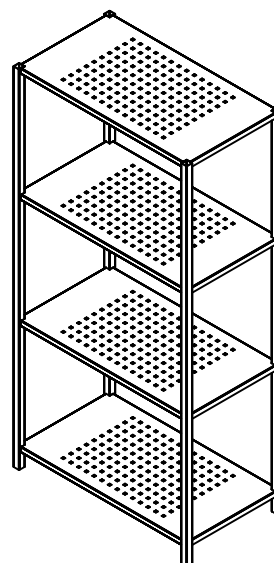
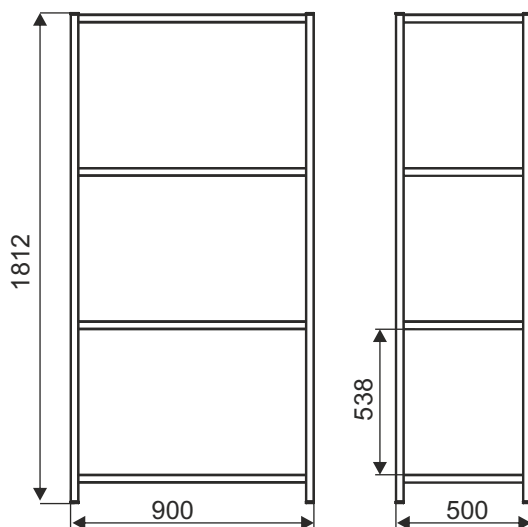

PRODUCT NAME	FINISH	INDEX
Stainless steel rack 900x500 H1800 with four shelves	stainless steel	922-380-207

### E4 EQUIPMENT FOR SHELVING, SHOP SHELVING

## FRONT STOP FOR SHELVING H-80 (OPENWORK 24,3)

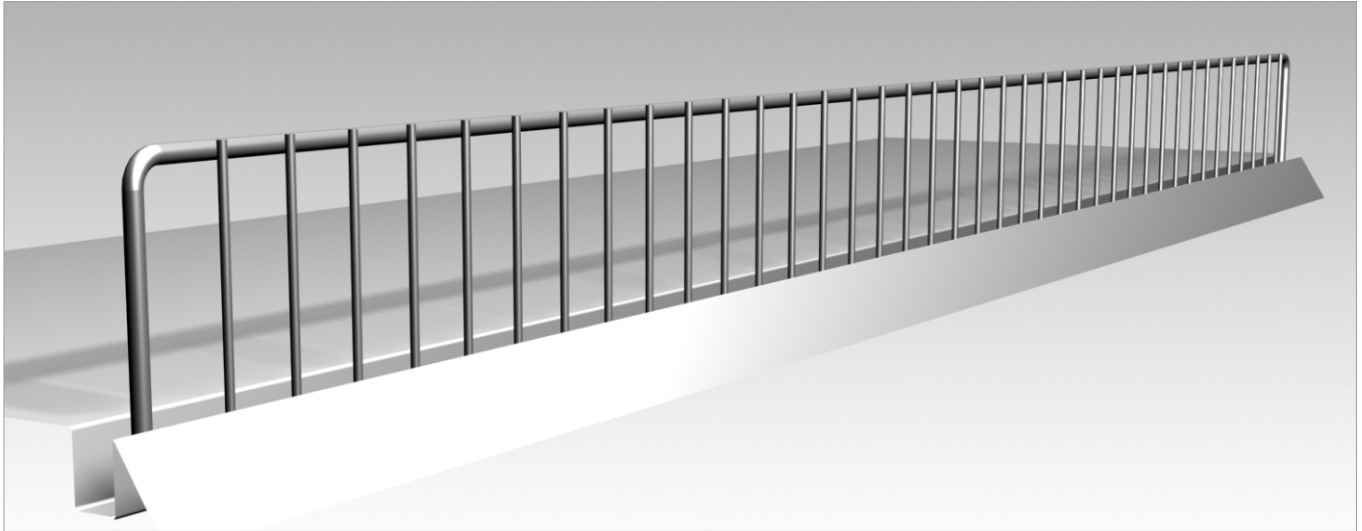

Standard finish: zinc plated; chrome on request

Front stop for shelving 982x80 mm 982

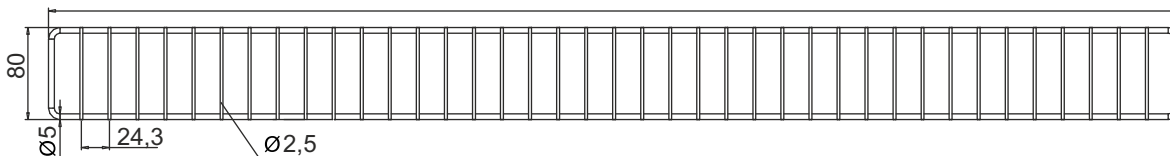

Front stop for shelving 982x80 mm V2 982

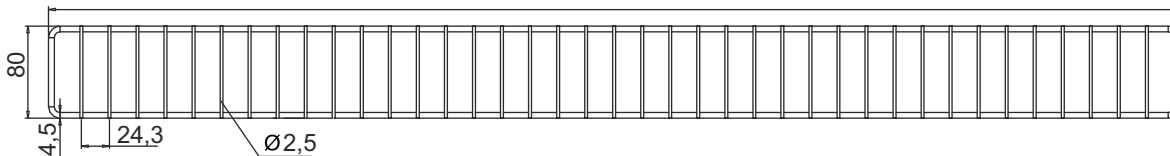

Front stop for shelving 1230x80 mm 1230

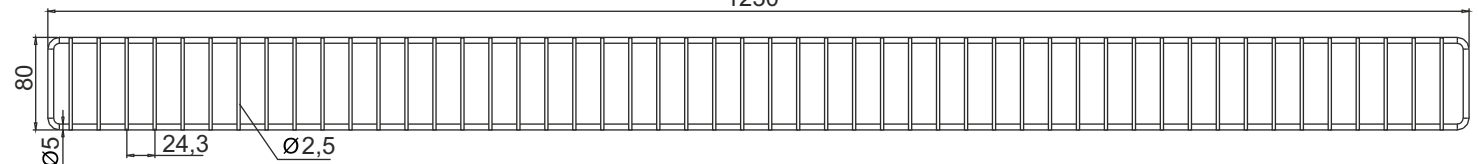

Front stop for shelving 1230x80 mm V2 1230

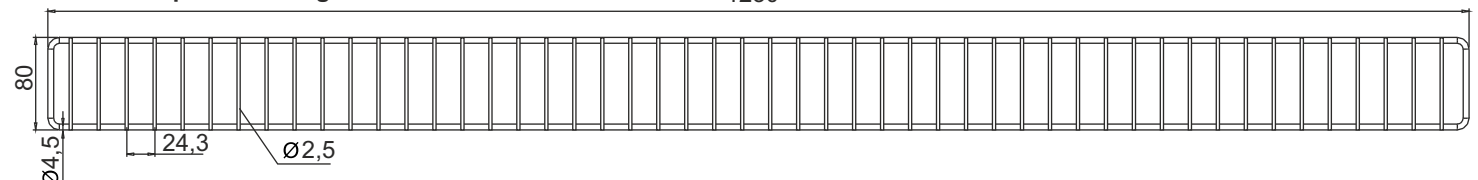

PRODUCT NAME	FINISH	INDEX
Front stop for shelving 982x80 mm (openwork 24,3 mmm)	zinc plated + lacquer	913-350-791
Front stop for shelving 982x80 mm (openwork 24,3 mmm) V2	zinc plated + lacquer	913-350-791v2
Front stop for shelving 1230x80 mm (openwork 24,3 mmm)	zinc plated + lacquer	913-350-792
Front stop for shelving 1230x80 mm (openwork 24,3 mmm) V2	zinc plated + lacquer	913-350-792v2

### E4 EQUIPMENT FOR SHELVING, SHOP SHELVING



## FRONT STOP FOR SHELVING H-60 (OPENWORK 24,3)

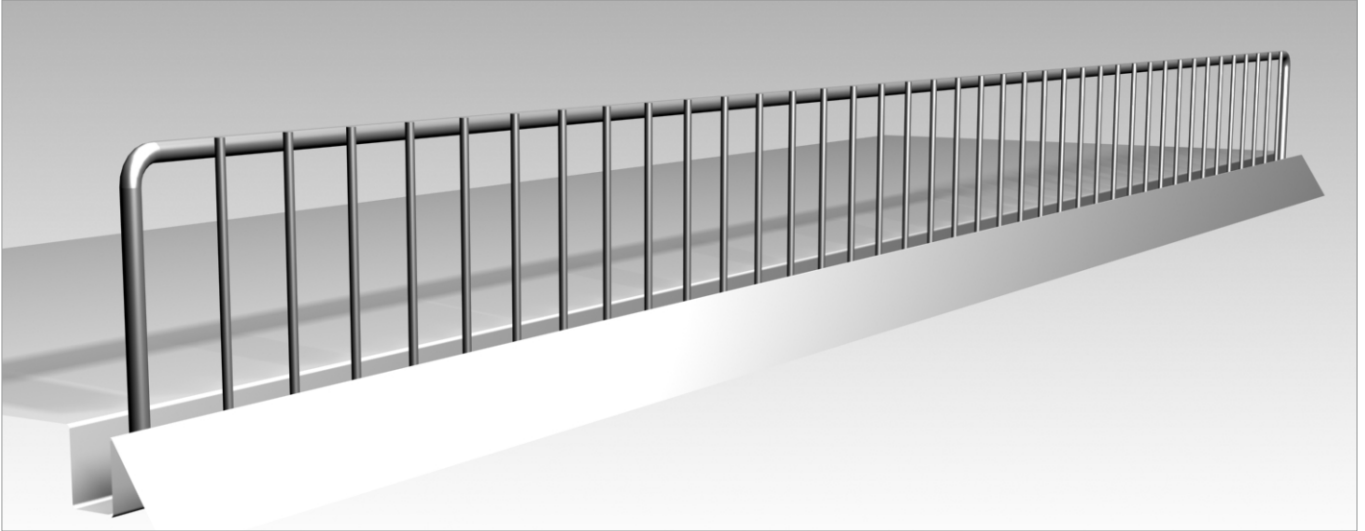

**Standard finish:** zinc plated;  
chrome on request

Front stop for shelving H-60 mm:

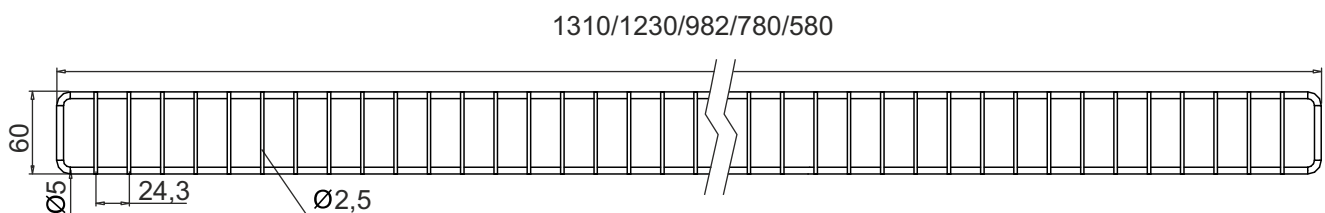

PRODUCT NAME	FINISH	INDEX
Front stop for shelving 580x60 mm (openwork 24,3 mmm)	zinc plated + lacquer	919-351-175
Front stop for shelving 780x60 mm (openwork 24,3 mmm)	zinc plated + lacquer	919-351-173
Front stop for shelving 982x60 mm (openwork 24,3 mmm)	zinc plated + lacquer	919-351-072
Front stop for shelving 1230x60 mm (openwork 24,3 mmm)	zinc plated + lacquer	919-351-073
Front stop for shelving 1310x60 mm (openwork 24,3 mmm)	zinc plated + lacquer	919-351-174

### E4 EQUIPMENT FOR SHELVING, SHOP SHELVING

## TRANSVERSE PARTITION MADE OF WIRE

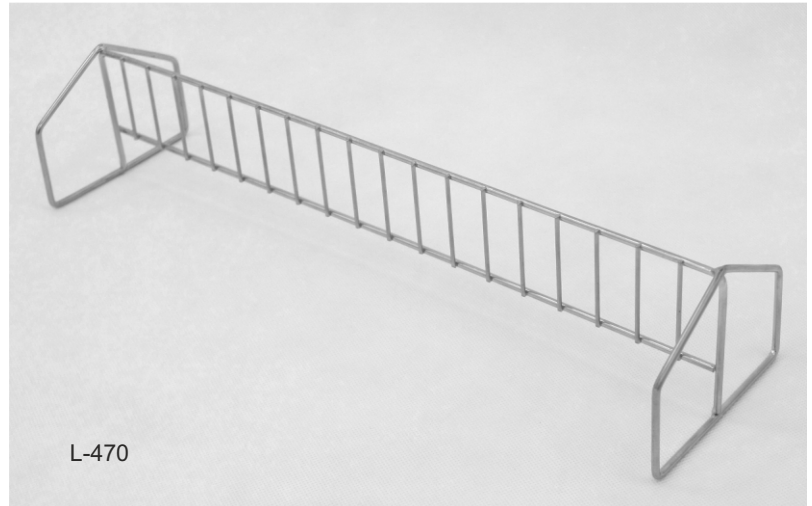
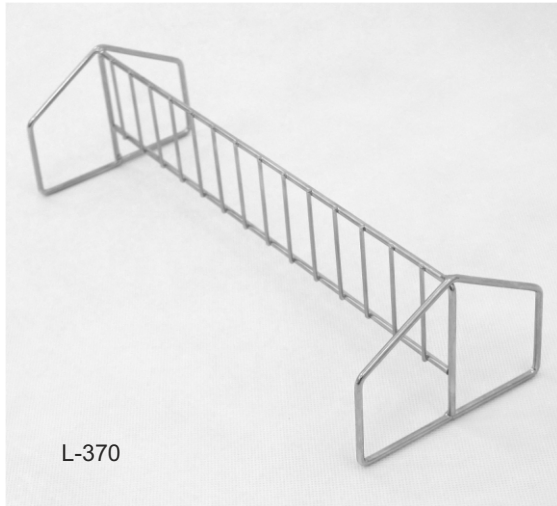

The transverse partition L-370 made of wire

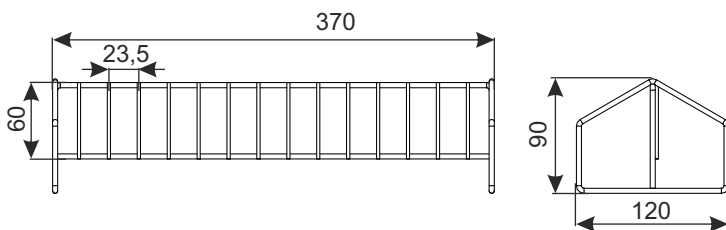

The transverse partition L-470 made of wire

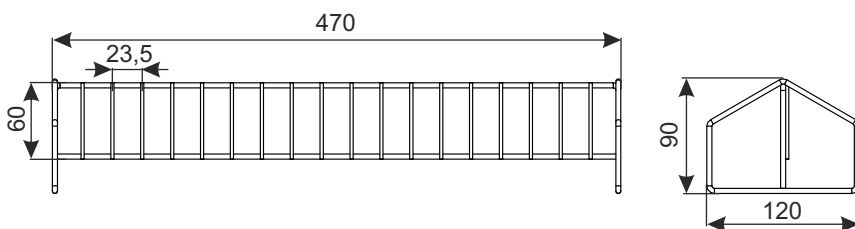

The transverse partition is used on the shelves  
**Standard finish:** zinc plated + lacquer

PRODUCT NAME	FINISH	INDEX
The transverse partition L-370 made of wire	zinc plated + lacquer	919-351-190
The transverse partition L-470 made of wire	zinc plated + lacquer	919-351-191

### E4 EQUIPMENT FOR SHELVING, SHOP SHELVING

## HOOKS

A variety of designs and means for mounting on racks, grates, railings, etc. means that every customer will find a solution that meets his expectations. The hooks are available in a broad range of galvanic coatings (i.a. chrome, satin chrome, zinc) or powder coated.

Examples:

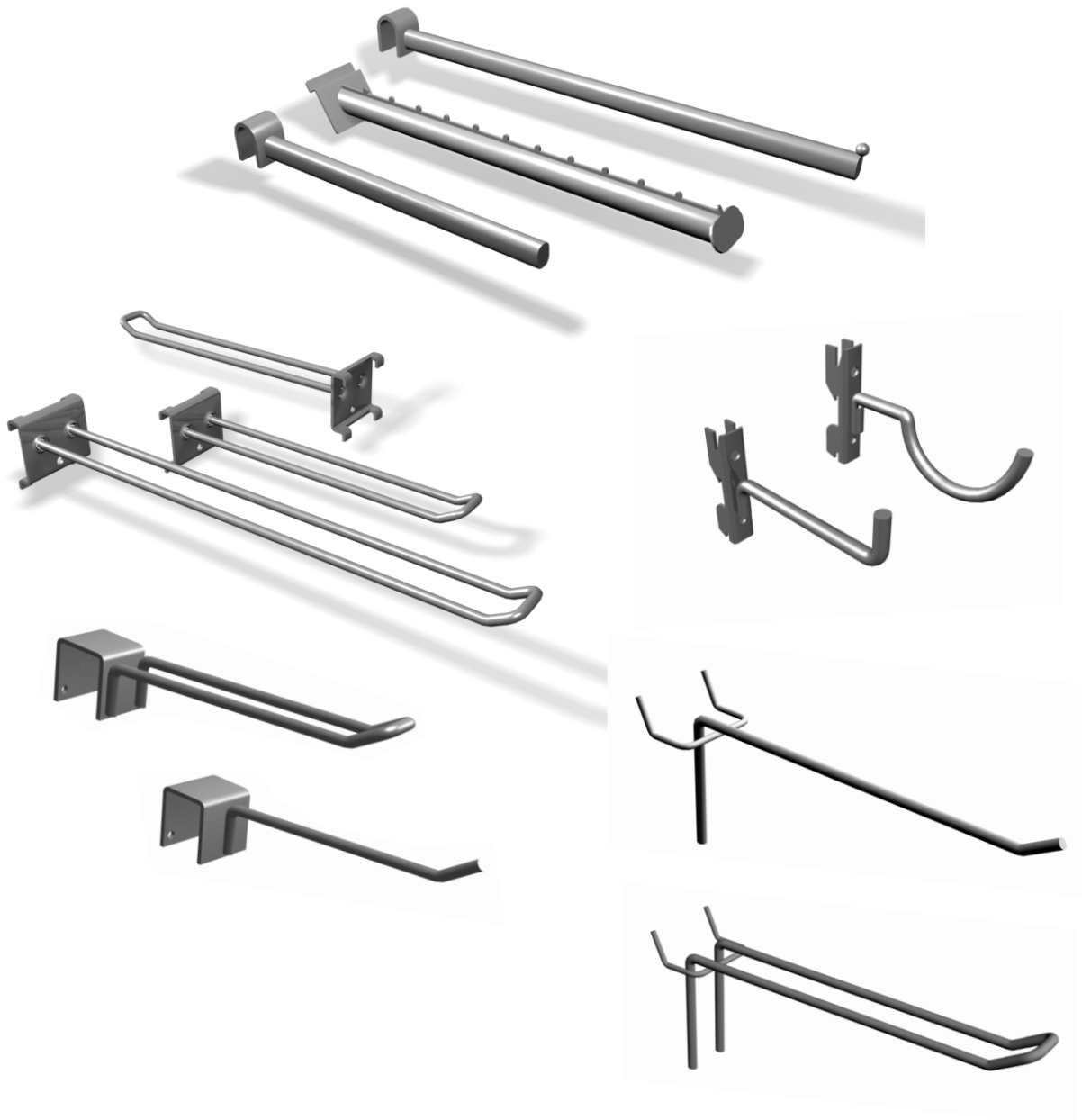

### **E4** EQUIPMENT FOR SHELVING, SHOP SHELVING

## SHELVING AND EXHIBITION STANDS POS & POP

Damix is a well-known manufacturer in the POS & POP industry.

We respond to Customer's requirements with solutions in range of displaying and selling of the goods - various types of displays, interior furnishing components, shelving solutions (adapted to various systems), hooks, hangers and other accessories. We design our own products or support our Customers in the design process, beginning from concept to final production. We cooperate with direct customers, as well as with design bureaus and advertising agencies. This webpage only shows a few examples of designs that were implemented, just as a sample of our production capabilities.

**In most cases these are protected designs.**

This page show only some of our products, making them a sample of our production capabilities.

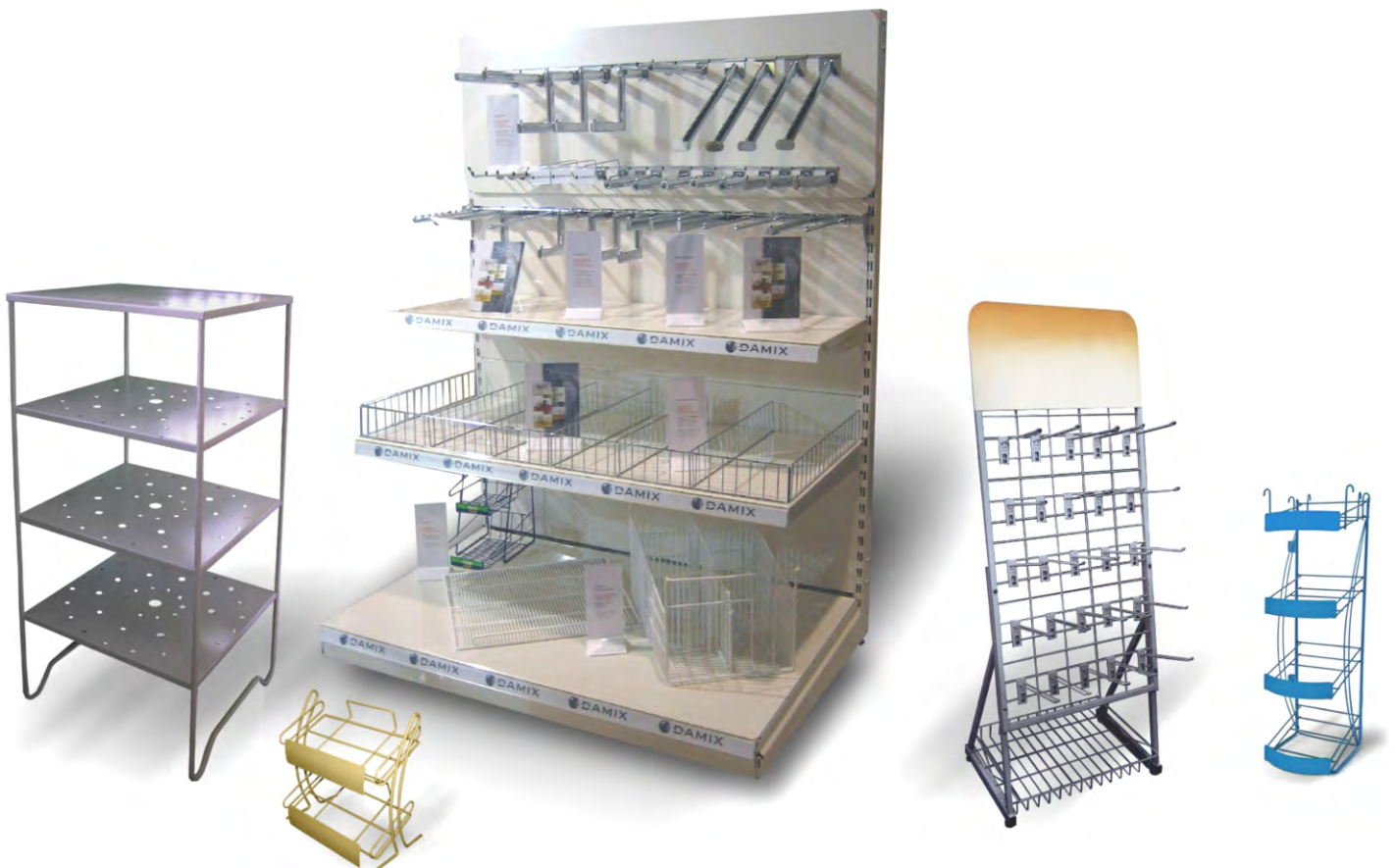

### **E4** EQUIPMENT FOR SHELVING, SHOP SHELVING

## SHELVING AND EXHIBITION STANDS POS & POP

Examples:



### **E4** EQUIPMENT FOR SHELVING, SHOP SHELVING

DAMIX Sp z o.o. ul. Bohaterów Czerwca 1956r. nr 3; PL - 87-500 Rypin  
tel. +48 54 280 34 93; fax +48 54 280 45 40; e-mail: damix@damix.pl; handel@damix.pl, www.damix.pl

All rights reserved  
05 03 2018

## SHELVING AND EXHIBITION STANDS POS & POP

Examples:



### **E4** EQUIPMENT FOR SHELVING, SHOP SHELVING



**PARKING**

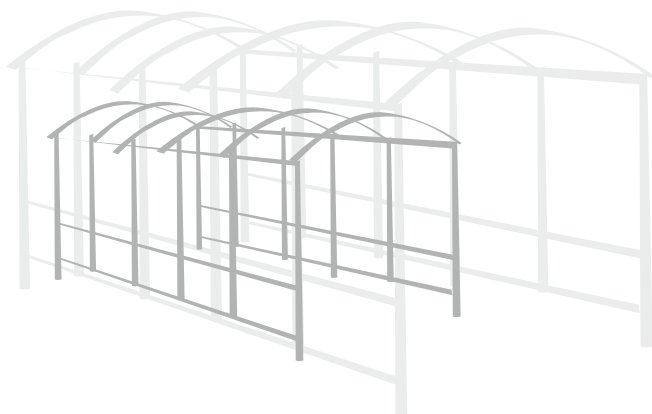

## **P** PARKING

- 1 Bicycle rack
- 2 Start keys L-1000, L-1200
- 3 Shopping trolleys shelter EURO-T
- 4 2-meter shelter EURO-T
- 5 Modular box for trolleys wariant A
- 6 Modular box for trolleys wariant B
- 7 Box for trolleys
- 8 Box (parking) made of stainless steel dedicated to kids' trolleys

*The reproduce without prior permission is forbidden. In order to improve, the manufacturer reserves the right to implement modifications in its products. Recommendations for installation and use the products are provided for informational purposes only and does not imply any liability on the part of the manufacturer.*

## **P** PARKING



## BICYCLE RACK



**Standard finish:** hot-dip zinc coating.

**Technical data:** steel pipe.  
1 rack is intended for 3 bicycle stands.  
Elements are screwed with bolts.

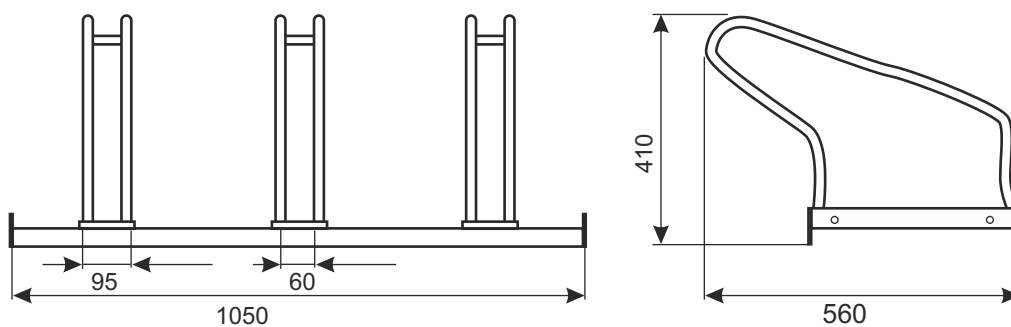

PRODUCT NAME	FINISH	INDEX
Bicycle rack	hot-dip zinc coating	919-350-833

## **P** PARKING

**START KEY L-1000MM (LP-100)/L-1200MM  
(TO FASTEN COLUMN OF TROLLEYS)**



**Lenght:** 1000 mmm lub 1200 mm,  
**Elements:** chain, fasten lock, fitting (assembling),  
**Finish:** zinc plated.

PRODUCT NAME	FINISH	INDEX
Start key L 1000	zinc plated	919-380-676
Start key L 1200	zinc plated	919-380-675

**P PARKING**

## SHOPPING TROLLEYS SHELTER EURO-T



*Back wall (Shelter with frame to fasten trolleys) is a standard element of the shelter equipment.*

**Finish:** zinc plated + powder coated  
**Construction:** steel  
**Walls and roof:**  
 standard - chamber polycarbonate 6 mm  
 optionally - solid polycarbonate 6 mm

**Standard colors** (other colors to be discussed):

<b>RAL 9006</b>	<b>RAL 9007</b>	<b>RAL 3020</b>	<b>RAL 6024</b>	<b>RAL 5010</b>
<i>light gray</i>	<i>graphite</i>	<i>red</i>	<i>green</i>	<i>blue</i>

*Optional equipment:  
rear building of the shelter:*

**Wymiary:**

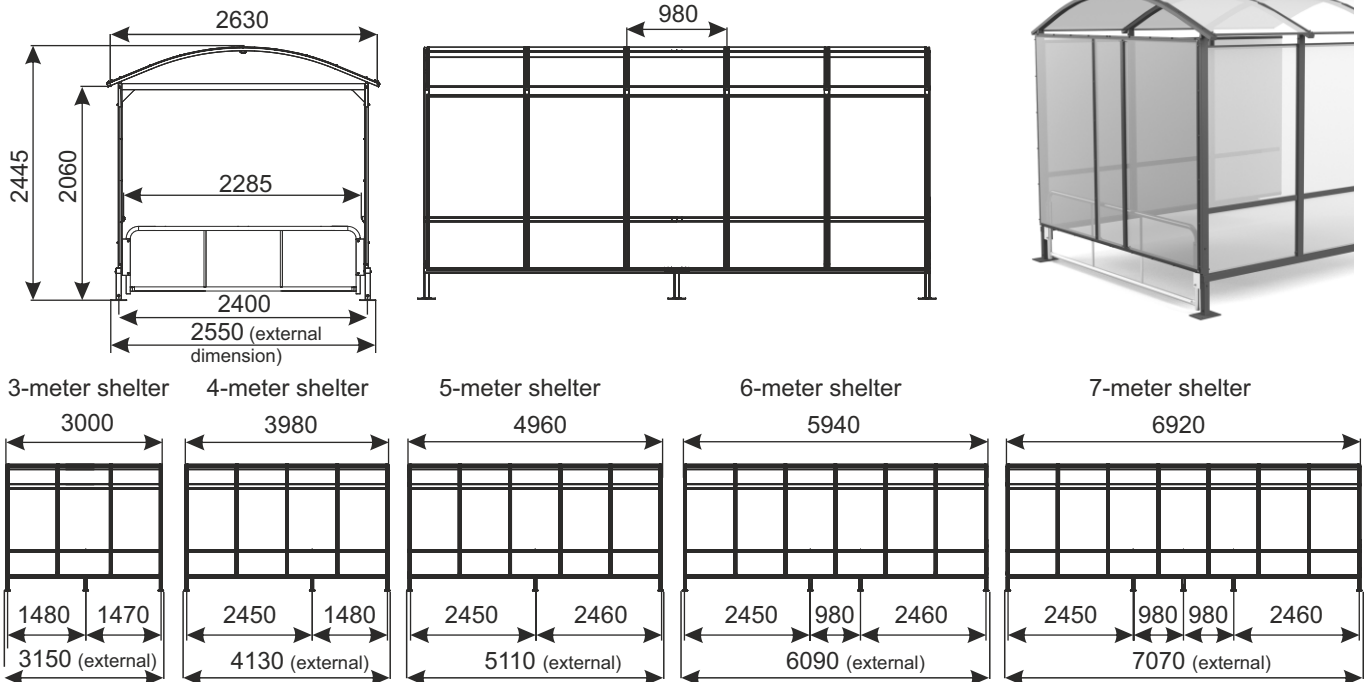

PRODUCT NAME	FINISH	INDEX
3-meter shelter EURO-T	zinc plated + powder coated	919-344-193
4-meter shelter EURO-T	zinc plated + powder coated	919-344-194
5-meter shelter EURO-T	zinc plated + powder coated	919-344-195
6-meter shelter EURO-T	zinc plated + powder coated	919-344-196
7-meter shelter EURO-T	zinc plated + powder coated	919-344-197
Rear building of the shelter (optional equipment)	zinc plated + powder coated	919-351-681

### **P** PARKING



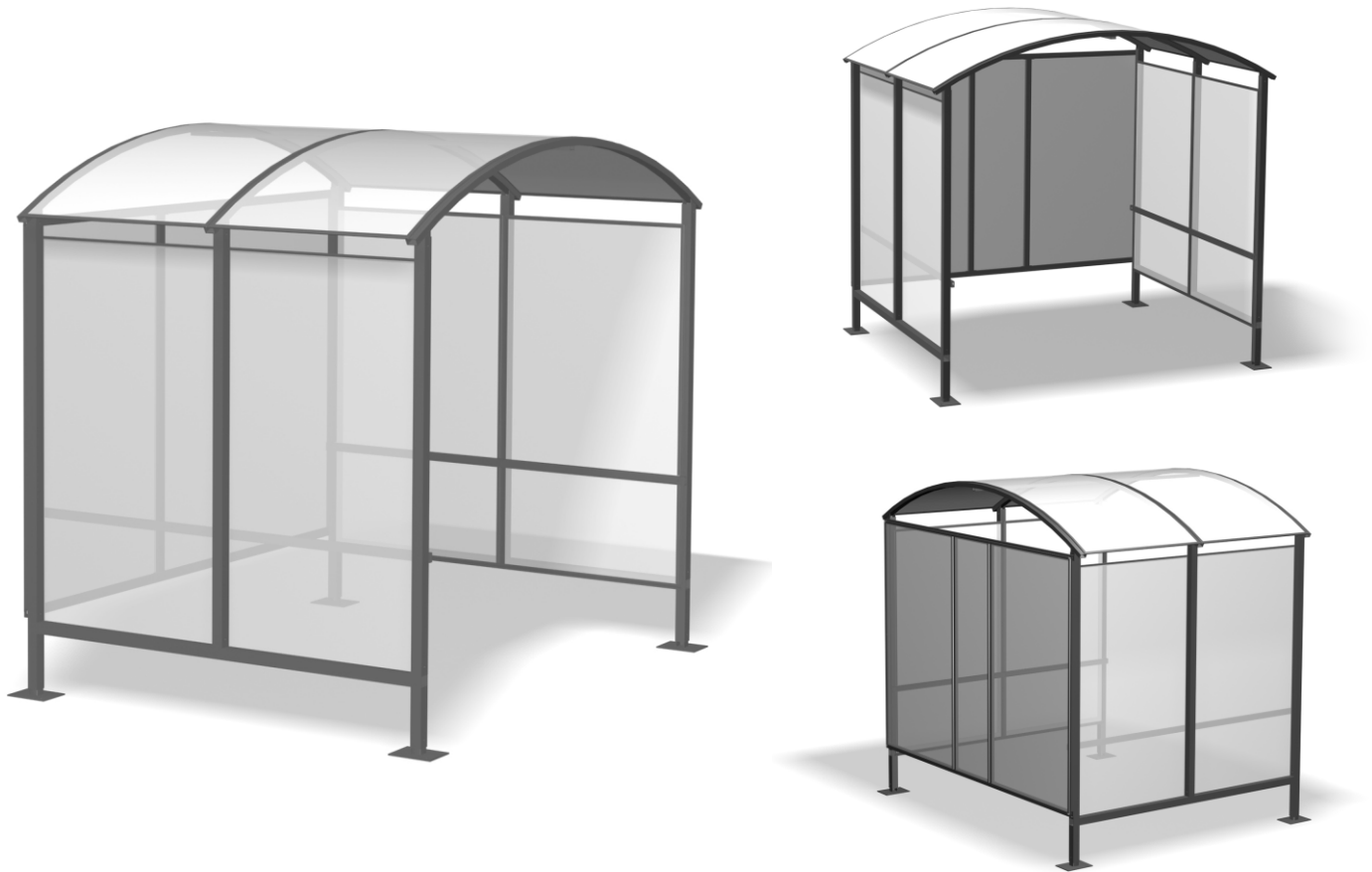

## 2-METER SHELTER EURO-T



Shelter is intended to i.e. as a place for bikes, smoking area.

**Finish:** zinc plated + powder coated  
**Construction:** steel  
**Walls and roof:** polycarbonate 6 mm

**Standard colors:**

-  RAL 9006 - light gray
-  RAL 9007 - graphite
-  RAL 3020 - red
-  RAL 6024 - green
-  RAL 5010 - blue

Other colors to be discussed.

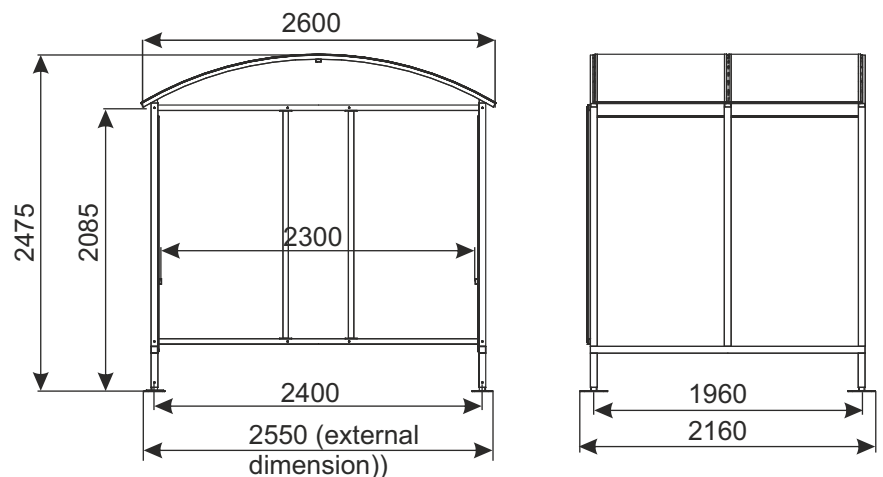

PRODUCT NAME	FINISH	INDEX
2-meter shelter EURO-T	zinc plated + powder coated	_____

### **P** PARKING

## MODULAR BOX FOR TROLLEYS WARIANT A

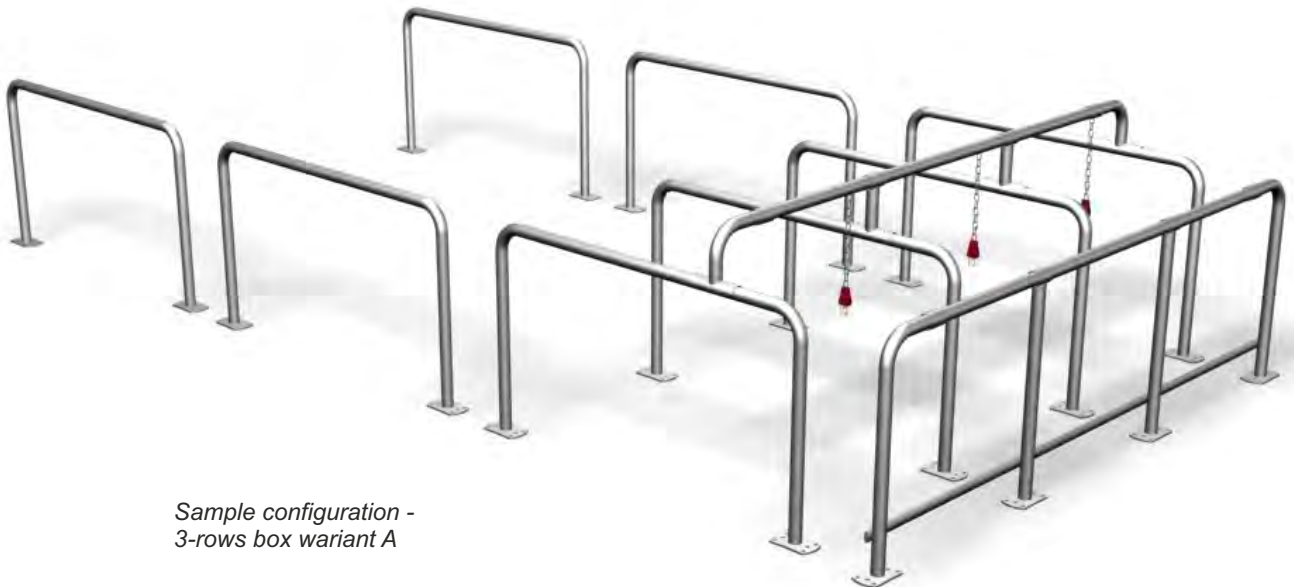

Sample configuration -  
3-rows box wariant A

Modular box for trolleys is used to park shopping and transport trolleys. The modular construction of the box allows for any configuration of the width, length and number of rows. That allows to adjust the box to the width and the planned amount of the trolley. Option A has modules that separate from each other rows of trolleys.

**Finish:** zinc plated and powder coated.

Modular box is available in two options of mounting to the ground:  
-with feet (bolted to the ground)  
-with anchors (concreted in the ground)

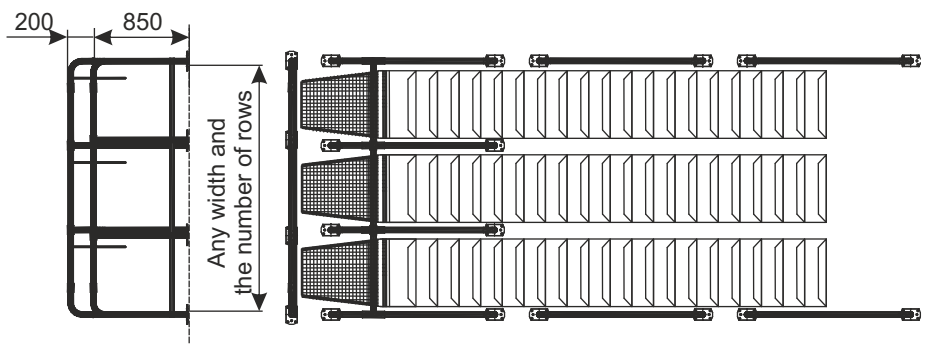
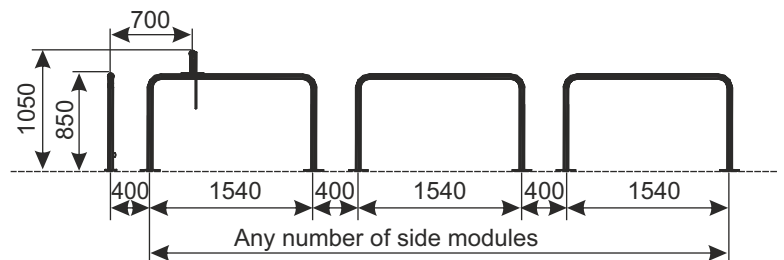

PRODUCT NAME	FINISH	INDEX
Modular box for trolleys wariant A	zinc plated and powder coated	_____

### P PARKING

## MODULAR BOX FOR TROLLEYS WARIANT B

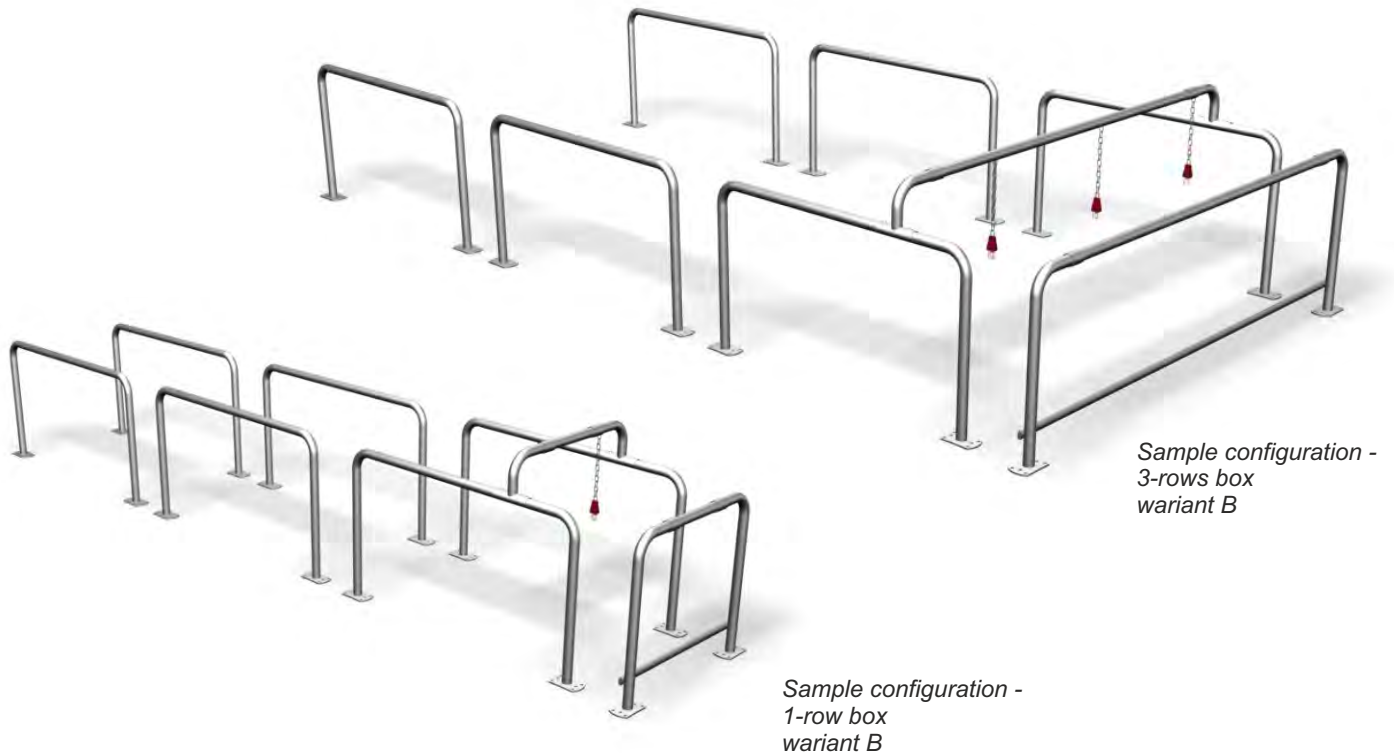

Modular box for trolleys is used to park shopping and transport trolleys. The modular construction of the box allows for any configuration of the width, length and number of rows. That allows to adjust the box to the width and the planned amount of the trolley.

The possibility of ordering the box with the width from 550 mm to 3000 mm allows for adjust the box to 1,2,3 or 4 rows with trolleys.

**Finish:** zinc plated and powder coated.

Modular box is available in two options of mounting to the ground:

- with feet (bolted to the ground)
- with anchors (concreted in the ground)

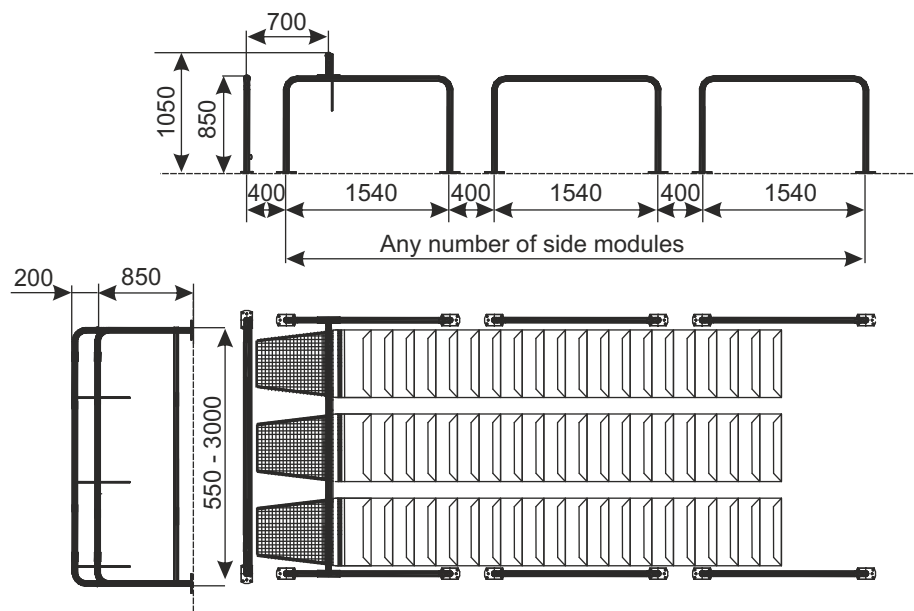

PRODUCT NAME	FINISH	INDEX
Modular box for trolleys wariant B	zinc plated and powder coated	_____

### **P** PARKING

## BOX FOR TROLLEYS



**Finish:** stainless steel.  
**Technical data:** Box made of pipe  
 screwed to the floor with screws,  
 designed for one row of trolley.

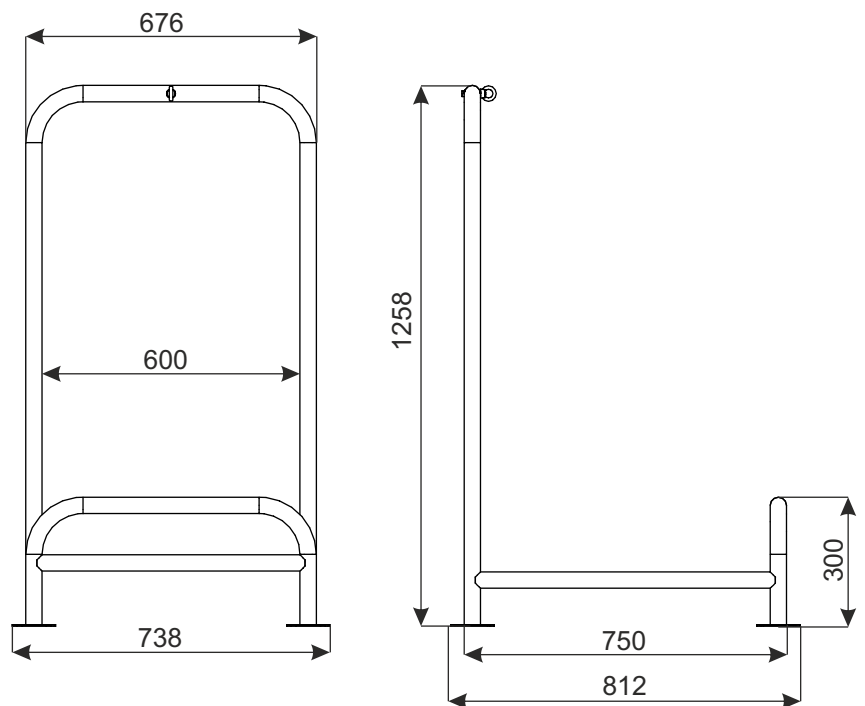

PRODUCT NAME	FINISH	INDEX
Box for trolleys	material - stainless steel	919-380-691

## P PARKING

## BOX (PARKING) MADE OF STAINLESS DEDICATED TO KIDS'TROLLEYS

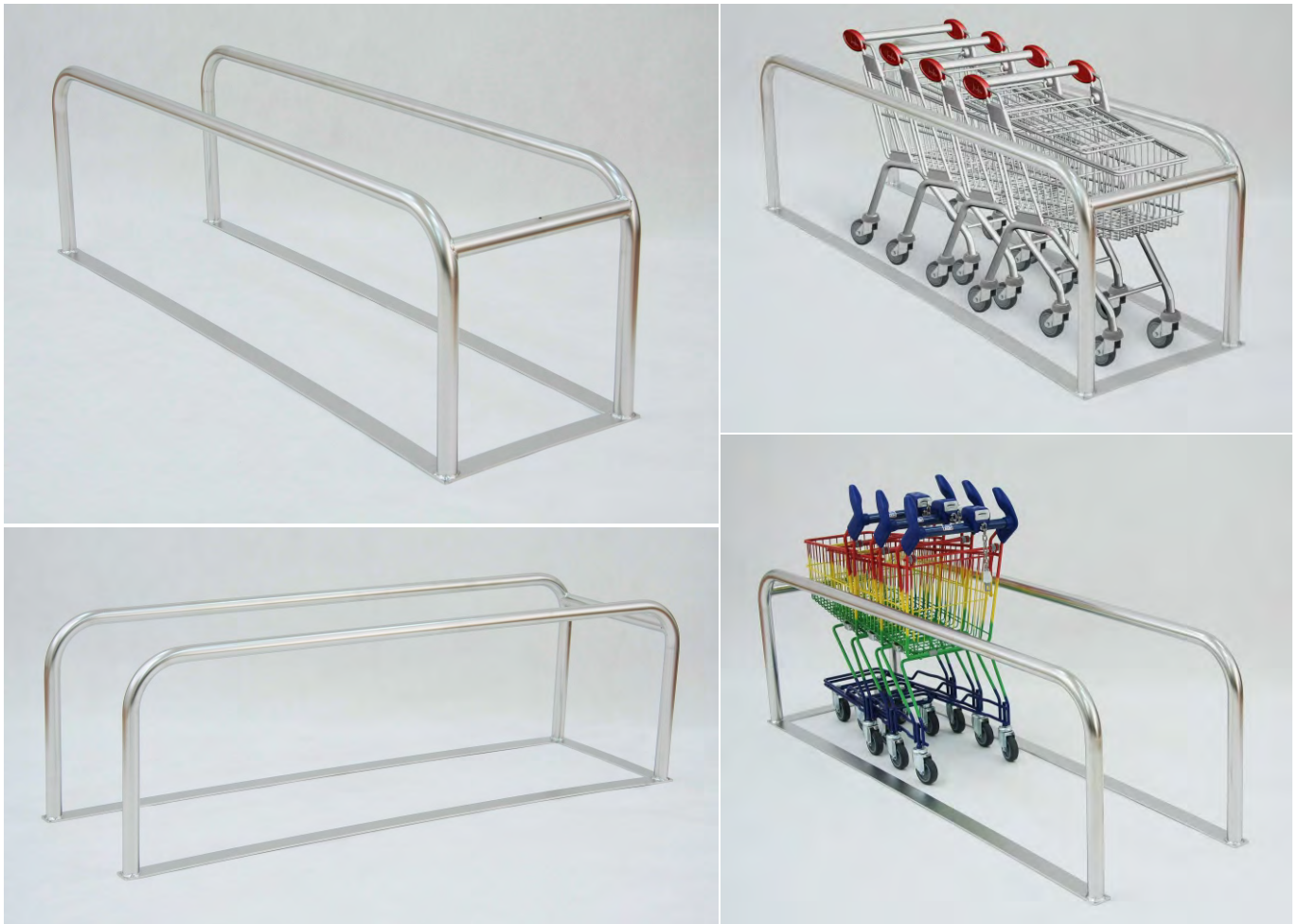

Box is intended to park small kids' trolleys with maximum width 390 mm: Avant MINI 20, Avant P20, MINI 22 L.

**Standard coating:** stainless steel and electropolishing.

**Technical data:** Box is made of tube and the base of flat bar; it's intended for one line of trolleys.

It's possible to fix starting key to the fixing of trolleys' column.

Fixing to the ground is maintained by its own by the usage of glue or adhesive tape.

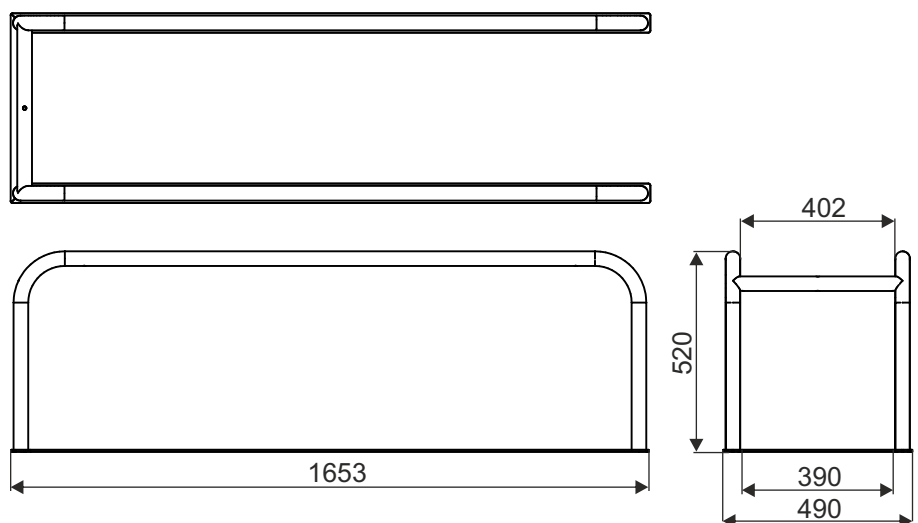

PRODUCT NAME	FINISH	INDEX
Box (parking) made of stainless steel dedicated to kids' trolleys	stainless steel and electropolishing	919-380-699

### **P** PARKING





**DAMIX Sp. z o.o.,**  
ul. Bohaterów Czerwca 1956r. nr 3,  
87-500 Rypin,  
tel. +48 54 280 34 93,  
e-mail: damix@damix.pl,  
handel@damix.pl



**Catalogue in different languages is available  
in electronic version at the address:**

[http://damix.pl/katalog/Katalog\\_DAMIX\\_PL.pdf](http://damix.pl/katalog/Katalog_DAMIX_PL.pdf)



[http://damix.pl/katalog/Katalog\\_DAMIX\\_DE.pdf](http://damix.pl/katalog/Katalog_DAMIX_DE.pdf)



[http://damix.pl/katalog/Katalog\\_DAMIX\\_EN.pdf](http://damix.pl/katalog/Katalog_DAMIX_EN.pdf)



[http://damix.pl/katalog/Katalog\\_DAMIX\\_RU.pdf](http://damix.pl/katalog/Katalog_DAMIX_RU.pdf)

