

SHOPPING TROLLEY CLASSIC 90 RELAXT

NEW!



The trolley is equipped with an original, modern handle with a built-in coin lock, anti-static protection and a place for an advertising. The construction of the handle ensures easy maneuvering of the loaded trolley.



TYPE	Classic 90 Relaxt
BASKET CAPACITY	85 l
LOADING OF BASKET	85 kg
TOTAL LOADING	125 kg
WHEEL DIAMETER	125 mm
FINISH	zinc plated + thermal setting lacquer
NESTING DISTANCE	180 mm

In the standard version shopping trolley has standard wheels. Optional accessories (inter alia wheels for travelator or with brake, coin lock, the logo and other accessories) require separate arrangements.

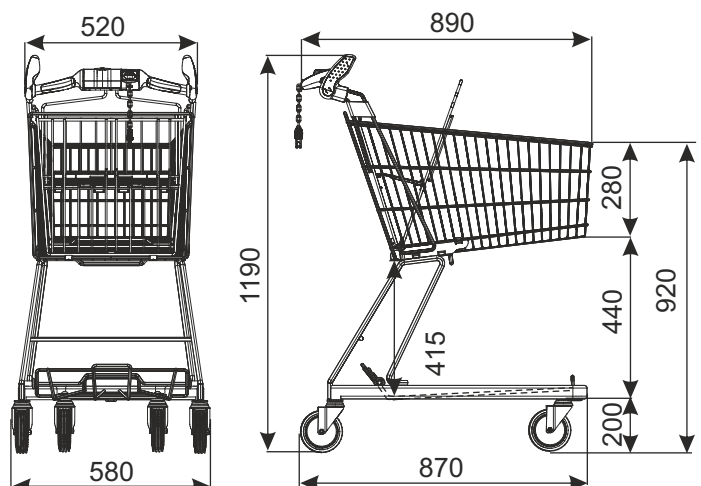

PRODUCT NAME	FINISH	INDEX
Shopping trolley Classic 90 Relaxt with toddler seat	zinc plated + lacquer	_____

W1 SHOPPING TROLLEYS