

ORDER PICKING TROLLEY

NEW!



Trolley in combination with slide-in box for packaging. (The slide-in boxes are not included in the equipment of the trolley.)



Finish: zinc plated+ lacquer.

Technical data: the structure of the trolley is made of a section and holders made of sheet metal intended for slide-in shelves, wire basket at the top and perforated sheet metal shelf, 4 swivel castors.

Wheel diameter: 125 mm.

Loading of one loading place: 25 kg

Total loading: 150 kg

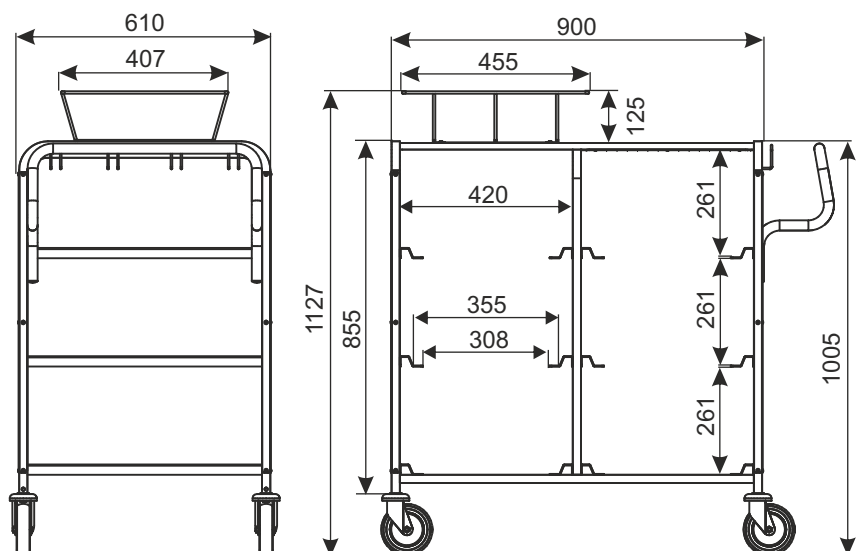

PRODUCT NAME	FINISH	INDEX
Order picking trolley	zinc plated + lacquer	919-351-067

W2 SPECIAL TROLLEYS, ACCESSORIES